

PL-597
33455970
Rev 1.0

FMS 350

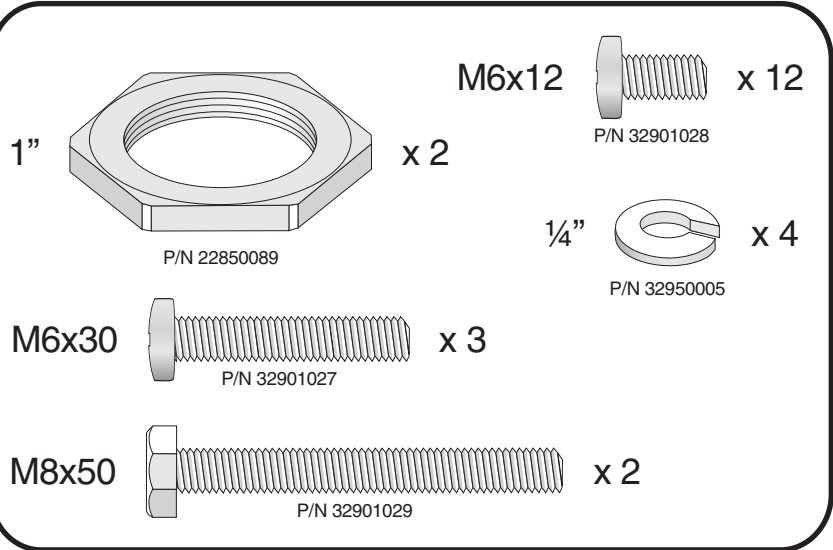

1:1

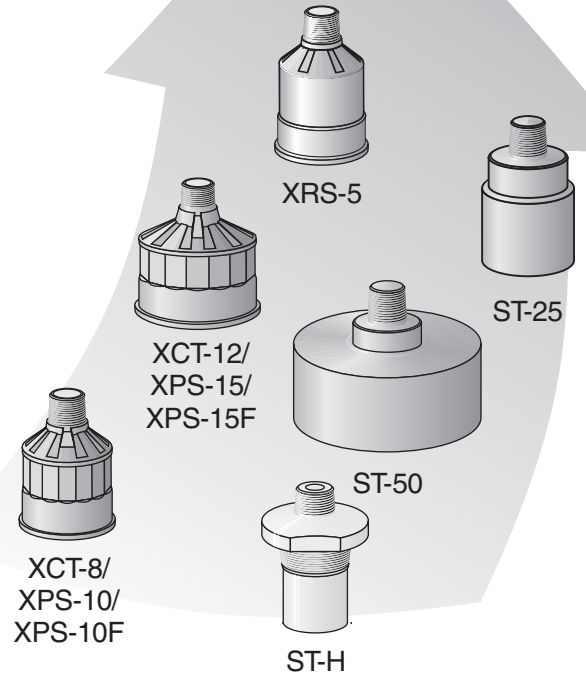
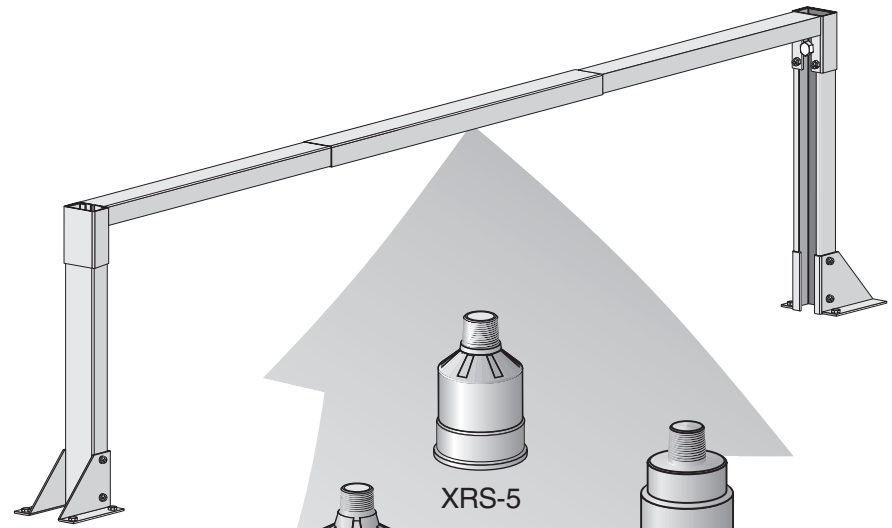

Canada

1954 Technology Dr., P.O. Box 42225,
Peterborough, Ontario, K9J 7B1
(705) 745-243 Fax: (705) 741-0466

Australia

182 Normandy Rd., Box 339, South Melbourne,
011-613-9695-2400 Fax: 011-613-9695-2450

Belgium

August van de Wielelei 97, 2100 Deurne, Antwerp,
32(0)3326 45 34 Fax: 32(0)3326 05 23

England

Century House, Bridgewater Rd, Worcester, WR4 9ZQ
44 1905 450500 Fax: 44 1905 450501

France

Parc de la Sainte Victoire, Bat. 5, 13590, Meyreuil,
33 4 42 65 69 00 Fax: 33 4 42 58 63 95

Germany

Friedrichstrasse 69, D-76703, Kraichol,
49 (0) 7251/9642-0 Fax: 49 (0) 7251/9642-15

Hong Kong

1 Hei Wen Street, Suite 602, Quarry Bay,
011 852-2856-3166 Fax: 011 852-2856-2962

Mexico

Amores # 1155, Col. Del Valle, 03100, Mexico D.F.,
52 5 573-27-28 Fax: 52 5 573-26-86

The Netherlands

Nikkelstraat 10, NL-4823 AB Breda,
31(0)76 5427 542 Fax: 31(0)76 5428 542

Switzerland

CP 168, Cdt de Plan 23, CH-1095 LUTRY
41 21 791 58 28 Fax: 41 21 791 58 40

USA

709 Stadium Drive, Arlington, Texas 76011
(817) 277-3543 Fax: (817) 277-3894

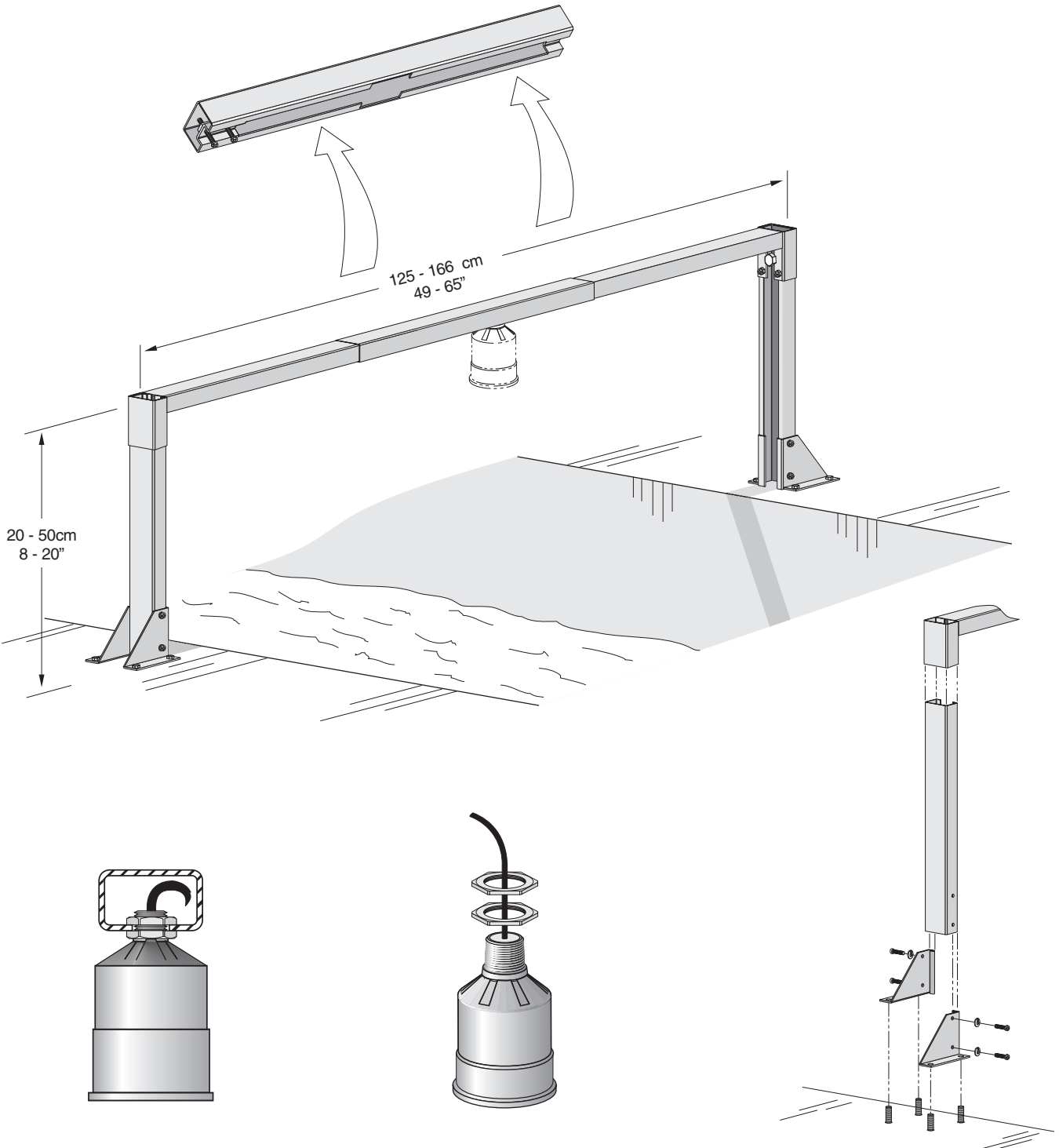

ST-H



ST-25

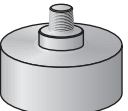

ST-50



XRS-5



XCT-8/
XPS-10/
XPS-10F



XCT-12/
XPS-15/
XPS-15F

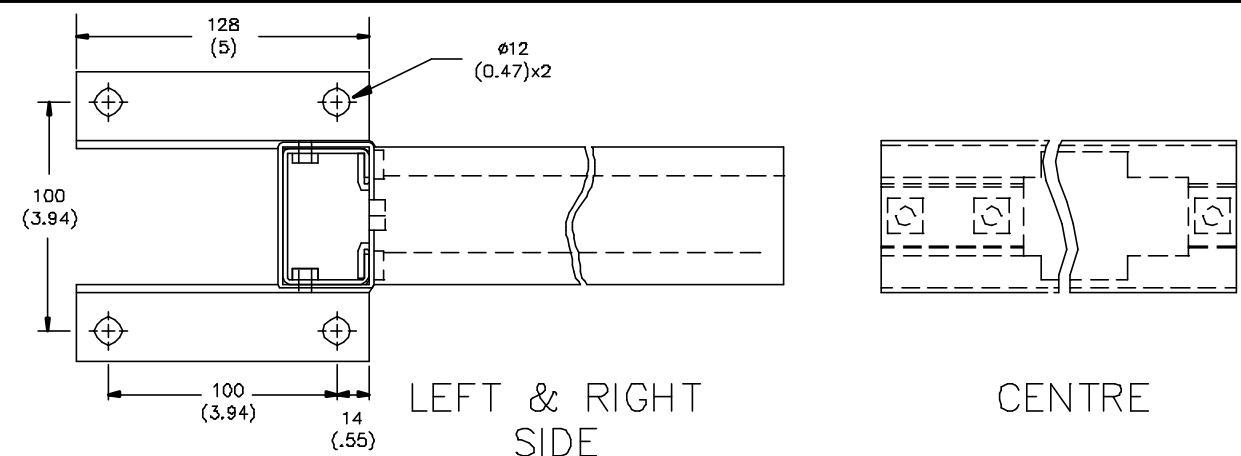

LEFT & RIGHT SIDE

CENTRE

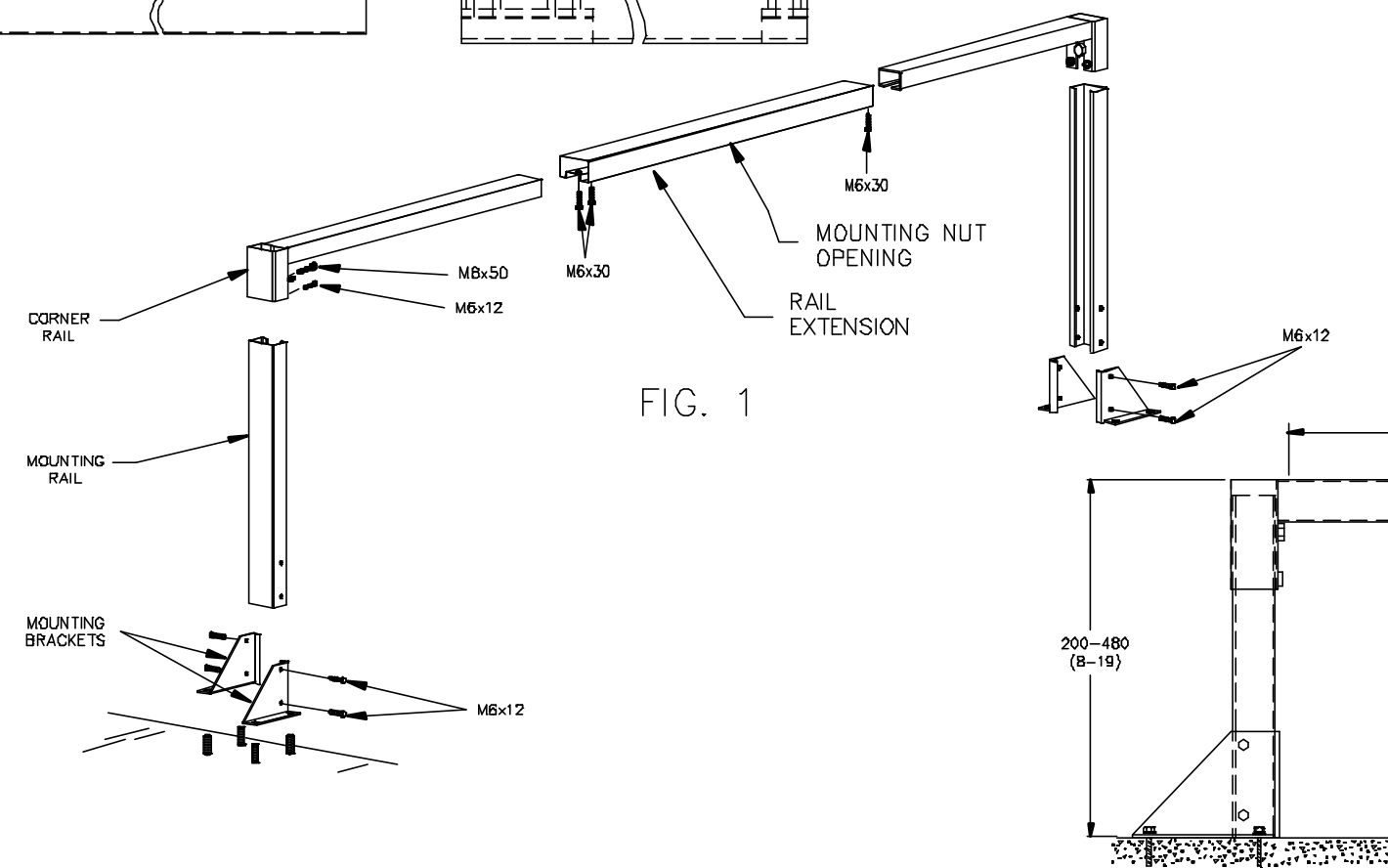
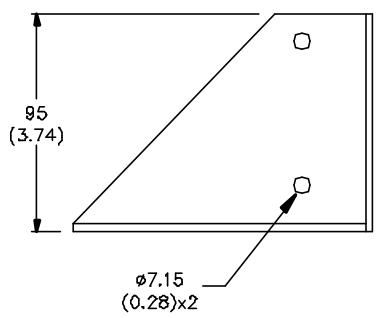
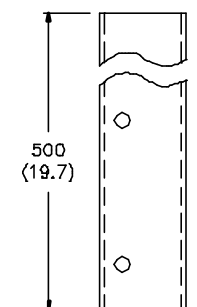
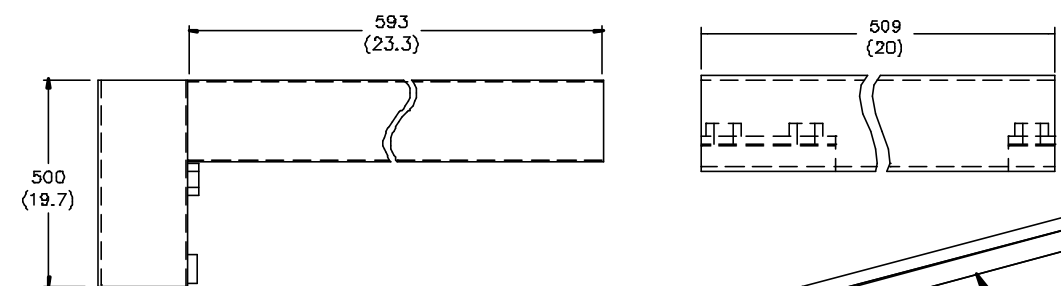

FIG. 1

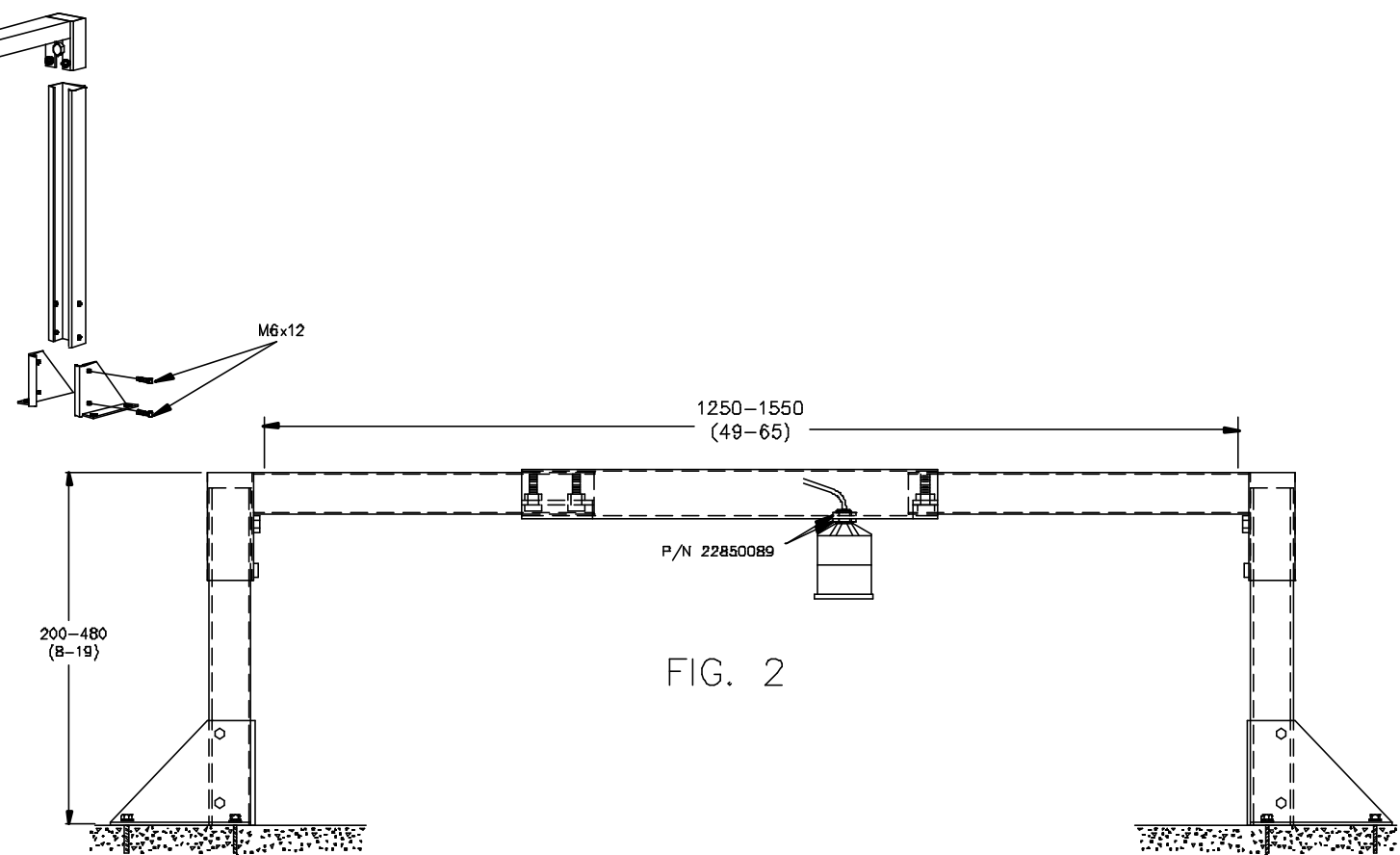

FIG. 2

NOTES:

- 1) ALL DIMENSIONS ARE IN mm () DENOTE DIMENSIONS IN INCHES.
- 2) USE TEMPLATE PROVIDED IN INSTRUCTION MANUAL TO LAYOUT HOLES FOR MOUNTING THE FMS 350.
- 3) SLIDE THE MOUNTING RAIL INTO THE SLOTS ON THE MOUNTING BRACKETS AND SECURE WITH FOUR M6x12 SCREWS. SECURE THE CORNER RAIL TO THE MOUNTING RAIL WITH TWO M6x12 SCREWS AND M8x50 BOLT, FOR BOTH THE LEFT & RIGHT SIDE. SLIDE THE RAIL EXTENSION ON THE END OF THE CORNER RAIL AND SECURE WITH THE TWO M6x30 SCREWS. SECURE THE OTHER END WITH A SINGLE M6x30 SCREW. REFER TO FIG 1 & 2.
- 4) MOUNT THE FACE OF THE FMS 350 BRACKET TO A SOLID HORIZONTAL SURFACE ENSURING IT WILL SUPPORT THE ADDED WEIGHT OF THE SENSOR, (MAX 1.4 kg (3LBS.) AFTER MOUNTING IS COMPLETE. MOUNTING HARDWARE BY CUSTOMER.
- 5) WHEN MOUNTING AN XCT, XPS 10, 15, 10F, 15F, XRS OR ST-H TRANSDUCER USE THE TWO 1" NUTS P/N 22850089, TO SECURE THE SENSOR TO THE FMS 350. REFER TO FIG 2. ENSURE THAT WHEN THE SENSOR IS MOUNTED IT WILL BE THE REQUIRED DISTANCE AWAY FROM ANY WALL OR OBSTRUCTION. REFER TO TRANSDUCER INSTRUCTION MANUAL.
- 6) FOR FURTHER DETAILS REFER TO THE INSTRUCTION MANUAL OR CONTACT YOUR MILLTRONICS REPRESENTATIVE.

USE DIMENSIONS ONLY - DO NOT SCALE

0	FOR CONSTRUCTION	RPC	JCM	JAN 14/00
No.	REVISION DESCRIPTION	DWG BY	APPRO.	DATE

CONFIDENTIAL
IMPORTANT NOTICE
 THIS DOCUMENT REMAINS THE PROPERTY OF MILLTRONICS AND IS SUBJECT TO REGAL. IT MAY NOT BE COPIED, AND IS ISSUED AND CAN BE UTILIZED ONLY FOR SUCH LIMITED PURPOSES AS MAY SPECIFICALLY HAVE BEEN AUTHORIZED BY MILLTRONICS. IT IS TO BE MAINTAINED CONFIDENTIAL, SINCE IT MAY CONTAIN PROPRIETARY INFORMATION AND TRADE SECRETS OF MILLTRONICS OR OTHERS. THE ITEMS DEPICTED MAY THEMSELVES BE THE SUBJECT OF PATENTS, INDUSTRIAL DESIGN REGISTRATIONS OR COPYRIGHTS OF MILLTRONICS OR OTHERS, AND THE ISSUE OF THIS DRAWING DOES NOT IMPLY ANY LICENSE UNDER ANY SUCH RIGHTS.
 COPYRIGHT MILLTRONICS
 ALL RIGHTS RESERVED

DRAWING SCALE NONE
DRAWN BY R. CLYSDALE
CHECKED BY I. WATSON
APPROVED BY J. MANN

TOLERANCES UNLESS OTHERWISE NOTED	THIRD ANGLE PROJECTION
1 PLACE DECIMAL ±0.3	
2 PLACE DECIMAL ±0.10	
3 PLACE DECIMAL N/A	
FRACTIONS	ANGLES ±0.5°

TITLE
FMS 350
CUSTOMER INSTALLATION
DRAWING



FILE No. 2365010800	SIZE B	DRAWING No. 23650108	REV. 0
PLOT AT 1=1			
JOB No.		SHEET 1 OF 1	