

3700 - DEM
Honeywell DE Smart
Transmitter Interface Module
Revision 1.3

USER MANUAL

April 1996

ProSoft Technology, Inc.
9801 Camino Media
Suite 105
Bakersfield, CA 93311
prosoft@prosoft-technology.com

Table of Contents

1 Product Specifications	1
2 Functional Overview	1
2.1 General	1
2.2 Data Flow	3
2.3 Reading from Honeywell Smart Transmitters	4
2.4 Writing to Honeywell Smart Transmitters	5
2.4.1 Performing a Download - Function 1	6
2.4.2 Performing an Upload - Function 2	6
2.5 PV Value Integrity	7
2.6 Data Base Mismatch	8
2.7 PLC Scan Time	8
2.7.1 Slow PV Updates	8
2.7.2 Resolving PLC Scan Time Issues	9
2.8 Terminating Instruments to the Module	9
2.8.1 Non-Redundant Configurations	10
2.8.2 Redundant Configurations	10
3 Getting Going - A Step by Step Approach	10
4 Ladder Logic Considerations	11
4.1 Ladder Logic Overview	11
4.2 Block Transferring to the module	11
4.2.1 DE Channel Write Data Block [BTW Block ID 1-16]	12
4.3 Block Transferring data from the module	14
4.3.1 Module Real Time Data [BTR Block ID 0]	15
4.3.2 Channel Configuration Data - Integer/Float [BTR Block ID 1 to 16]	17
4.3.3 Channel Configuration Data - ASCII [BTR Block ID 17 to 32]	20
5 Hardware Diagnostics	20
5.1 Normal Operation of Module (Fault LED Off)	20
5.2 Faulted Status of Module (Fault LED On)	21
5.2.1 DE Init Error	21
5.2.2 DE Reset Error	22
5.2.3 DE Timeout Error	22
5.3 Clearing a Fault Condition	22

Appendix

A	Detailed Honeywell DE Parameter Descriptions
B	Data Structure - SCAN 3000 Memory map
	Data File Layout
	Data Object Definitions
	Detailed Register Locations
C	Block Transfer Buffers
	BTR 0 Real Time Data Update
	BTR 1-16 Channel Configuration Data - Integer/Float
	BTR 17-32 Channel Configuration Data - ASCII
	BTW 1-16 Channel Configuration Data
D	FTA Connections
E	Support, Service and Warranty
F	PLC 5 Ladder Logic - SCAN 3000 example

Product Revision History

- Revision 1.0 2/15/96
Initial release of product
- Revision 1.1 3/17/96
Revision to data base
Addition of database mismatch logic
- Revision 1.2 3/24/96
Revisions to data base to account for MV number of PV
- Revision 1.3 4/8/96
Release for product
- Activate bad pv flag
 - Added pv over and under range bits
 - Added module revision data to block id 0
- Revision 1.31 4/18/96
- Revision 1.32 4/19/96
- Revision 1.33 4/21/96
- Fix the DE Timeout condition that was occurring when the PLC Scan Time was exceeding 75 ms
 - Allow the DEM to change an instrument from DE CFG mode for Analog to DE
 - No longer NaN the SV values during the mismatch condition
 - Fixed MV handling of PV Characterization

Product Updates

Product and documentation updates will be available, as soon as they are available, off our Internet facilities. Please feel free to check our Web Site for update information, and to download the information you are interested in.

Our Internet addresses are as follows:

Web : <http://www.prosoft-technology.com>

FTP : <ftp.prosoft-technology.com>

1 Product Specifications

The ProSoft Technology, Inc. 3700-DEM module is a hardware product designed to allow the Allen-Bradley PLC platform to interface directly with Honeywell DE Smart Transmitters. The product includes the following characteristics:

General Specifications

- 1771 Form Factor - Single Slot
- PLC interface via standard BTR/BTW commands
- Interfaces with Honeywell Smart Transmitters operating in the DE mode
- Supports up to 16 single PV transmitters, 4 multivariable transmitters with 4 PVs each, or a mix of single and multivariable equaling 16 inputs
- Full read/write access to instrument database
- SCAN 3000 compatible memory map in PLC
- Instrument database mis-match verification
- Interfaces directly to Honeywell Field Terminal Assembly (FTA)
- Supports redundant and non-redundant FTA implementations
- Single cable connection from DEM module to FTA
- External 24 VDC source connection on front of DEM module for instrument loop power (Future revision will support backplane powering of instruments loops)
- Independent Reset Pushbutton for module
- LEDs for visual module status:
 - Module Active
 - Module Fault
 - DE Channels 1-8 Active/Error
 - DE Channels 9-16 Active/Error
- Operation via simple ladder logic
- Communication Status Error Codes and statistics returned per port
- Memory mapping is pre-assigned to optimize data access and to ease implementation
- Data file requirements - SCAN 3000 applications
 - Integer : 403 words
 - Floating Point : 256 values (512 words of memory)
 - ASCII : 960 words
 - Total : 1619 words

Hardware Specifications

- Backplane Current Load : 0.5 amps w/ external 24 VDC Source
2 amps if using backplane power option (future)
- Operating Temperature : 0 to 60 Deg C
32 to 140 Deg F
- Storage Temperature : -40 to 85 Deg C
-40 to 185 Deg F
- Relative Humidity : 5-95% (w/o condensation)
- FTA Connector : 50 pin Honeywell FTA
- 24 VDC Connector : 2 wire, screw termination

2 Functional Overview

This section is intended to give the reader an functional overview of the 3700-DEM module. Details associated with the ladder logic and the memory map are not covered in this section, but can be found in Section 4 and in the Appendix.

2.1 General

The 3700-DEM module has been designed to provide a tightly integrated communications interface between the Allen-Bradley 1771 platform and the family of Honeywell Smart Transmitters.

The 3700-DEM module consists of two DE CPU microcontrollers, each which provide communications with 8 DE Smart Transmitters. The figure below shows the following functional components on the module:

- A Primary DEM controller responsible for the overall operation of the board, including:
 - Access to Shared Ram between DE CPU #1, #2
 - Backplane communications with Allen-Bradley PLC
 - Transferring data from DE processors to PLC
 - Transferring write commands from PLC to DE processors
 - Data Base Mismatch comparisons
 - LED Status indicators
- Two DE CPU 68HC11 microcontrollers, each with the following:
 - Eight data receivers which provide input signal conditioning (noise filtering, surge limiting, etc.) for the serial data inputs
 - An output channel selector and driver circuitry allowing the DE processor to output data base write commands to any channel
- The Shared RAM provides a mailbox through which the Primary controller and the two DE processors can communicate. Access to this Shared RAM is strictly controlled by the 80C32
- The DEM module is connected to a Field Terminal Assembly (FTA), not shown in diagram, which includes 250 ohm range resistors to convert the 4-20 ma current signals from the Smart Transmitters in the DE mode into 1-5 Volt signals

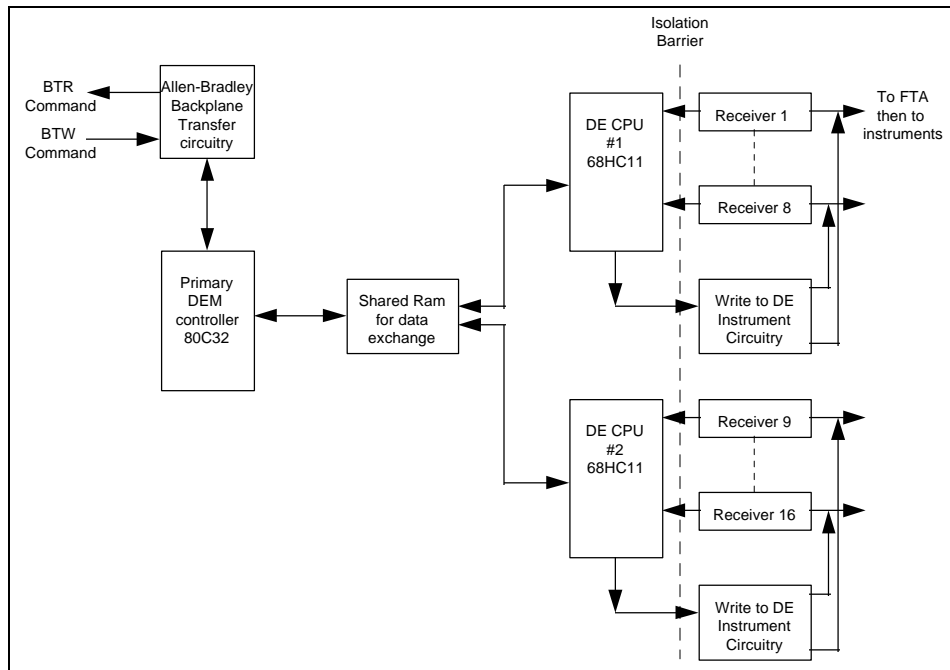

Both Single and/or Multivariable Honeywell Transmitters operating in the DE mode are supported by the module. Supported Honeywell instruments include:

- ST 3000 Smart Pressure Transmitter
- STT 3000 Smart Temperature Transmitter
- SMV 3000 Smart Multivariable Transmitter
- MagneW 300 Smart Magnetic Flowmeter
- SCM 3000 Smart Coriolis Mass Flowmeter
- SGC 3000 Smart Gas Chromatograph

There can be Single and Multi Variable instruments connected to the DEM module, in any mix totaling 16 logical DE Channels. An example configuration could be as follows:

DE Channel	Physical Type	Instrument
1	SV	ST 3000 Pressure
2	SV	STT 3000 Temperature
3	MV	PV 1 - SMV 3000
4		PV 2
5		PV 3
6		PV 4
7	MV	PV 1 - SMV 3000
8		PV 2
Boundary		Cannot cross boundary with an MV Transmitter
9	SV	ST 3000 Pressure
10	SV	ST 3000 Pressure
11	SV	STT 3000 Temperature
12	SV	STT 3000 Temperature
13	MV	PV 1 - SMV 3000
14	MV	PV 2
15	MV	PV 3
16	MV	PV 4

Multivariable Considerations

The following 'rules' must be followed when integrating multivariable devices:

1. No instrument can be physically wired to the FTA terminals within the logical limits of another instrument
2. Cannot cross from Channel 8 to 9 with an MV transmitter, or rollover from Channel 16 to 1
3. The Tag ID must be identical and non-blank across all logical channels configured for use by a multivariable device
4. You must perform a Download Command on the physical channel in order to change the number of PVs being transmitted (DECONFIG can only be written to the first slot of a multivariable transmitters)

Data transfer between the module and PLC ladder logic is implemented using standard Block Transfer commands (BTR and BTW). There is a large amount of data that is returned from each instrument, and all of this data is made available to the ladder logic. The data being returned from the module is detailed in the Appendix.

Through the use of ladder logic programming, applications can be developed which can:

1. Use all of the data being returned from the module (as in the SCAN 3000 configuration) or,
2. Selectively extract only the data relevant to the application from the BTR data buffer

The decision on which data to use from the module is completely a function of the programmer and of the application. A great deal of the PLC data base layout was designed with the Honeywell SCAN 3000 system in mind, but if not using the SCAN 3000 to interface with the PLC then the PLC data base can be modified.

2.2 Data Flow

The movement of data between the transmitter and the PLC is important to understand. The diagram below depicts the data movement paths which are supported in this application (Diagram shows SCAN 3000 implementation, but functionality will be similar for other interfaces).

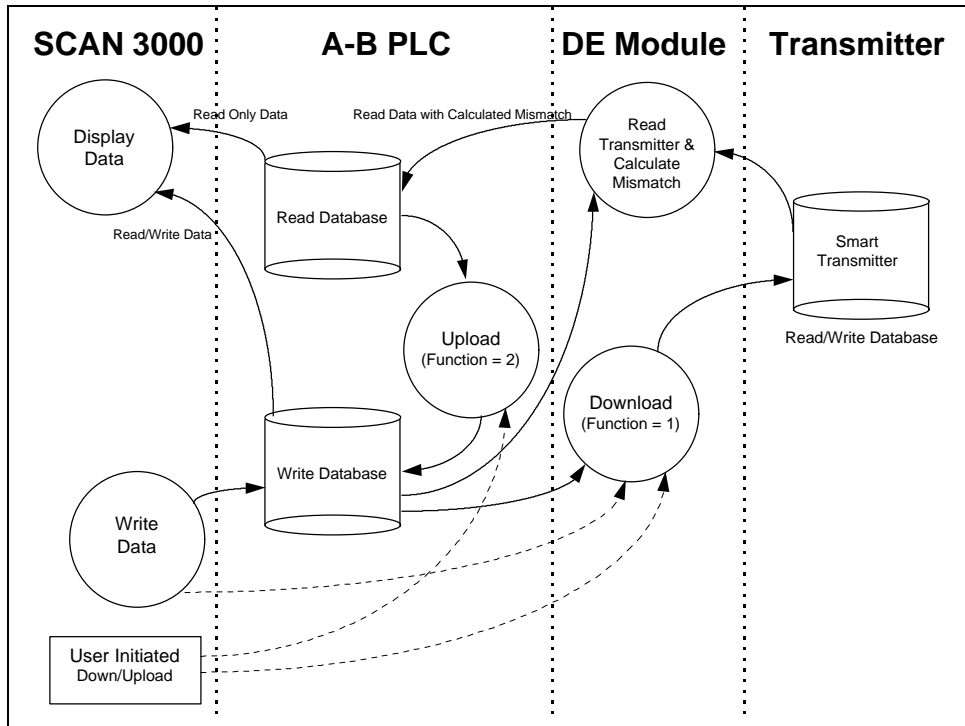

Important

One of the underlying concepts which must be understood is that the PLC is considered the 'owner' of the data. Therefore the contents of the PLC data space, in particular the Write Data space, are the data to which all other data is compared.

Step	Description
Power Up	The read database will be populated by the DEM from the Smart Transmitter, and the write database will remain unchanged from its initial value in the PLC. The user can then choose to upload or download
Read DE Transmitter & Calculate Mismatch	The module continuously transfers from the Smart Transmitter database to the read database, comparing the Write and Read files in the PLC for mismatch. The module performs a mismatch comparison between the two and sets the status in the read database accordingly
Upload	Populates write database with that of the Smart Transmitter (via the read database in the PLC). Upload may be a continuous loop if the module is to be configured in an unsecure mode. Otherwise, the Upload should only be initiated by a user
Download	Download populates the Smart Transmitter with the values in the write database from the PLC. First download will put the Smart Transmitter in the DE mode (future) (if isn't already)

2.3 Reading from Honeywell Smart Transmitters

The ProSoft 3700-DEM module allows the PLC to read the real time data, the status data, and the configuration parameters in the Smart Transmitter's database. An overview of the data which is available from a transmitter follows (A detailed listing and description of the data is in Appendix A of this manual) :

Type	Description
Real Time	PV Value (Last Good Value and NaN value)
	SV Value (Last God Value and NaN value)
Status	Module Status - Health indication
	Data Base Mismatch Status flags
	PV Update Counter
	SV Update Counter
	Communication Error Counter
Configuration	Status Messages - ASCII
	Function - Download/Upload
	Tag Name - ASCII
	Serial Number - ASCII
	DE Configuration - Data base mode
	Damping Value
	PV Characterization
	Sensor Type
	PV Number (channel # on MV transmitter)
	Number of PVs - (# of channels on MV Transmitter)
	Upper Range Value - URV
	Lower Range Value - LRV
	Upper Range Limit - URL
Lower Range Limit - LRL	

The Status and Configuration values are being received from the Smart Transmitter on a continuous basis to the DEM. The DEM will not actually receive these values until a complete data base has been acquired from the instrument. This cycle can take anywhere from 15 to 90 seconds, depending on the instrument type. Once the data base has been read into the DEM module, the cycle will automatically start over again. In this fashion the DEM module, and therefore the PLC Read Database, are being updated completely on a regular basis.

The flow of data from the instrument all of the way to the Operator display is shown in the following diagram.

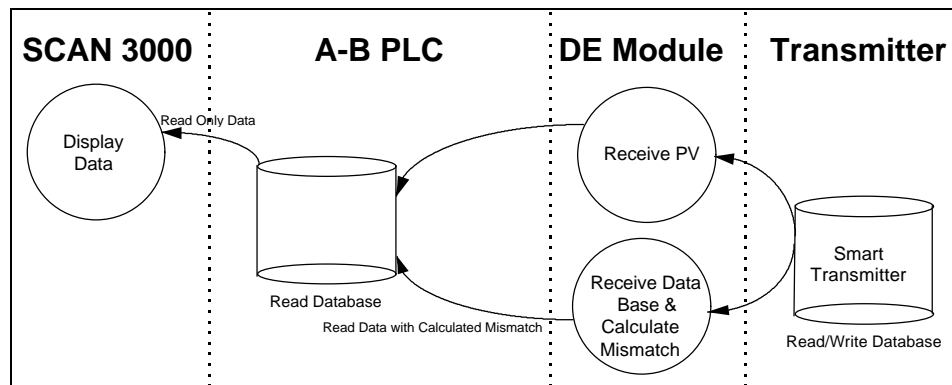

2.4 Writing to Honeywell Smart Transmitters

In addition to the read functionality described above, the ProSoft 3700-DEM module will allow the PLC application to change some of the configuration values in the Honeywell Smart Transmitter. These values are written to the instrument by pre-loading the appropriate register locations in the PLC and initiating a Download (Function = 1) cycle.

The module will execute the Download Command and return the completion status in the Device Status word. Upon receipt of the completion bit, the Download write register should be cleared.

The example ladder provided with the module and listed in the Appendix performs the logic necessary to implement the Download functionality. We recommend the use of this logic, at least as a starting point, with simple modifications to the addressing.

The configuration parameters which can be written to the instrument are as follows:

Type	Description	Write to Transmitter	Mismatch Tested
Configuration	Function - Download/Upload	N	N
	Tag Name - ASCII	Y	Y
	DE Configuration	Y	Y(1)
	Damping Value	Y	Y
	PV Characterization	Y	Y
	Sensor Type	Y	Y
	Upper Range Value - URV	Y	Y
	Lower Range Value - LRV	Y	Y
	Upper Range Limit - URL	N	Y(2)
	PV Num -	N	Y(2)
	Number of PV	N	Y(2)

(1) DE Configuration modes which disable the database read also disable Mismatch testing
 (2) These values are written to the module for Mismatch testing purposes

2.4.1 Performing a Download - Function 1

The Download Function performs the step of writing the new data to the instrument. Until the Function is set to 1, the Write Database is not moved the instrument.

The flow of write data from the operator interface station to the instrument is shown in the following diagram. The Write Database image in the PLC is being moved to the DEM module for Mismatch comparison purposes.

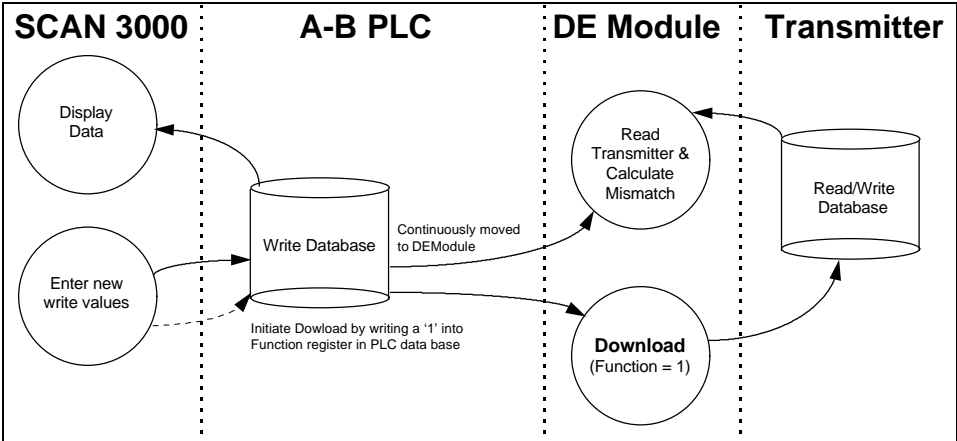

2.4.2 Performing an Upload - Function 2

The Upload Function performs the step of moving the data that has been read from the instrument database from the PLC Read database into the PLC Write database.

This function is useful for initializing the Write database when the Read database is known to contain good data. Performing this step will clear any Mismatch conditions which exist.

The flow of write data from the during the Upload function is shown in the following diagram:

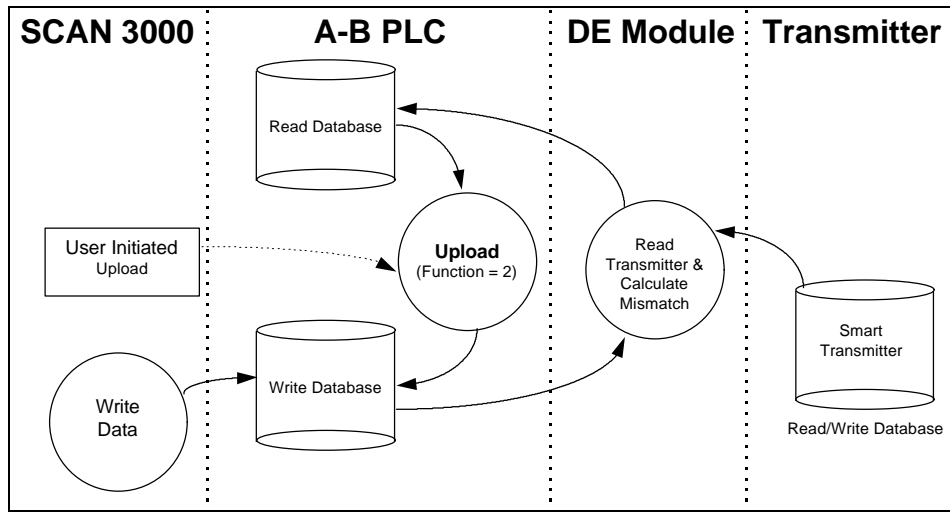

2.5 PV Value Integrity

A great deal of effort is put into the task of assuring the integrity of the PV value presented to the PLC. Two forms of the PV and SV variables are made available to the PLC:

PV - Last Good Value

This value is the PV value unconditioned by the Data Base Mismatch. Care should be exercised when using this PV value as the scaling, which is based on the URV/URL/LRV parameters, may not be accurate.

PV - NaN Value

This value represents the 'safe' PV value, as this value has been conditioned by the Data Base Mismatch logic. If a condition affecting the integrity of the PV value is detected, the PV Value is forced to a NaN value (Not A Number)

During the normal operation the DEM module is performing integrity checks of the health of the PV value. Should a condition be detected which could affect the integrity, the Bad PV Flag is set (Device Status Word 1/13). The four conditions which will cause the Bad PV Flag to be set are:

PV Update Timeout

If the PV value has not been updated within 6 seconds (24 PV update cycles), the flag will be set

Data Base Mismatch

If any data base mismatch condition is detected, the flag will be set

SFC Write Detected

If an SFC write to the instrument data base is detected, the flag will be set. Note that in a redundant application, the SFC Write Detected condition will be detected when a Download command is executed from the other module or from the SFC unit.

FTA Not Present

If the FTA connector or the 24 VDC power supply is disconnected, the flag will be set.

In order to clear the Bad PV Flag, the offending condition will need to be cleared, and under most circumstances will have to wait until a new data base has been received from the instrument.

2.6 Data Base Mismatch

Data base mismatch testing is performed by the DEM module on the write parameters received from the PLC. The mismatch status is returned to the PLC for use by the ladder logic or for status available to the PLC in via the Data Mismatch Active Flag in Device Status Word #1.

Bit	Description
0	Mismatch - URL
1	Mismatch - LRV
2	Mismatch - URV
3	Mismatch - Damping
4	Mismatch - DE Configuration
5	Mismatch - PV Characterization
6	Mismatch - Sensor Type
7	Mismatch - Tag ID
8	Mismatch - PV Number
9	Mismatch - Number of PV Values
10	Mismatch - Cold Junction Reference
11	Mismatch - Open Thermo Couple Detection
12	Mismatch - Freq 50

Important

The mismatch condition is performed in the DEM module on the write parameters everytime the module receives a new copy of the parameters from the PLC.

Clearing the data base mismatch condition is executed in one of several ways:

1. Wait for the mismatch condition to clear. If the mismatch was generated as the result of a Download Command, the mismatch will be cleared when the next data base is fully read from the instrument
2. Perform a Download Command to the instrument. If the write data is known to be correct executing a Download will move the new values to the instrument. If the Download is successful, the mismatch condition will clear when the next data base is fully read from the instrument
3. Perform an Upload Command.

2.7 PLC Scan Time

The DEM module's performance can be adversely affected if the scan time of the PLC becomes excessive. Two ways in which performance can be impacted are discussed below

2.7.1 Slow PV Updates

As the PLC scan time increases the frequency of Block Transfer execution decreases. As the module uses the Block Transfer commands to transfer the updated PV values (as well as all other data) to the PLC, the PV update time will be impacted. To gauge the impact of scan time, we have prepared the following table indicating the Block Transfer Read frequency of Block ID 0 (PV Update Block) as a function of scan time:

PLC Scan Time	Block ID 0 Update Time (Local rack)
5 ms	80 ms
20 ms	100 ms
40 ms	220 ms
60 ms	340 ms
70 ms	400 ms
80 ms	480 ms

2.7.2 Resolving PLC Scan Time Issues

There is a very simple solution which is available if an application is encountered where either the PV update time is unsatisfactory or the PLC scan time is excessive.

This solution involves calling the logic containing the Block Transfer instructions more often. In the example in the Appendix, this would mean calling Subroutine 3 more frequently. This could easily be accomplished by inserting several additional JSR 3 instructions strategically in the main ladder logic.

Using the STI functionality

Do not attempt to resolve PLC scan time issues with the DEM module by enabling the STI to call the Block Transfer logic (ie., SBR 3). When a BT Command is within the operation of an STI routine, the BT Timeout bit is set. This will cause erratic Block Transferring with the DEM module. This method is **not** recommended.

2.8 Terminating Instruments to the Module

The method for terminating the Honeywell Smart Transmitters to the 3700-DEM is through one of several Field Terminal Assembly (FTA) units. Several different FTA units are available from ProSoft as part of the 3700-DEM product package.

The transmitters are connected to the FTA through twisted pair wiring on a point to point basis. An FTA Cable, available in lengths from 1.5 meters to 50 meters, is used to cable the FTA to the 3700-DEM module. A typical connection hierarchy is shown in the following diagram.

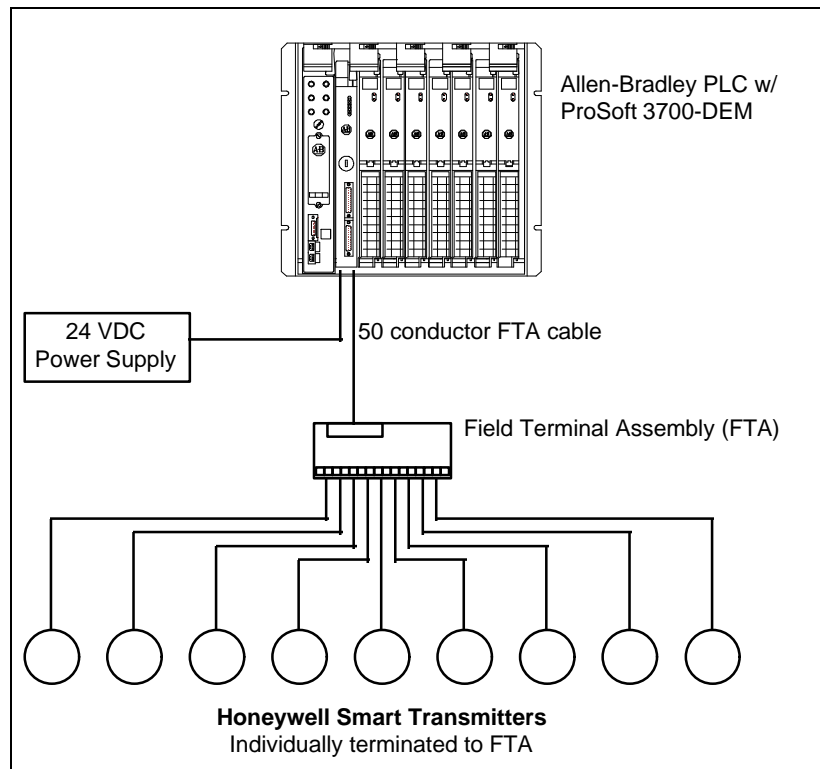

The module, in its current release, requires an external 24 VDC power supply to provide instrument power. The 24 VDC power source is connected to the front of the 3700 module via screw terminals.

2.8.1 Non-Redundant Configurations

In a typical Non-Redundant configuration, a single FTA will be connected to a single module. The FTA available in this configurations is:

Honeywell FTA Model	Description	Size
MU-TSTX03	Compression Terminals	15.24 x 12.065 cm

Note : This unit is provided by ProSoft Technology

This unit is shipped standard with each 3700-DEM unit, along with a 3 meter cable. If other configurations are required, simply contact the factory.

2.8.2 Redundant Configurations

The DE I/O system supports the implementation of redundancy at the I/O level very easily. Using a standard Redundant FTA, a set of instruments can be connected to two 3700-DEM modules. These two 3700 modules can be in separate racks or in the same racks, with either one or two PLC processors themselves in a redundant configuration.

Honeywell FTA Model	Description	Size
MU-TSTX13	Compression Terminals	30.73 x 12.065 cm
MU-TSTX53	Screw Terminals	30.73 x 12.065 cm

Note : These units are available from ProSoft Technology upon request

3 Getting Going - A Step by Step Approach

Installation of the 3700-DEM module is easily accomplished. Installation into a system requires only a few steps. Following is a step-by-step procedure for getting an application operational:

1. Identify rack and slot location for module.
2. Identify the data files for Block Transfer buffering and DE data exchange
3. Use existing example logic (See attached) provided on disk as a starting point
4. Modify this logic for correct physical rack and slot locations
5. Modify the logic for the data file locations to be used
6. Install the card into rack and download ladder logic
7. Connect the FTA cable to the front of the module
8. Connect the instruments to the FTA
9. Power up equipment and monitor module operation via data table

Once the hardware has been installed and the necessary programming has been downloaded to the processor, the system is ready (Presuming all other system components are safely ready).

Step	Example	User Application
1. Identify Rack position	Rack 0 Group 3 Slot 0	Rack : ____ Group : ____ Slot : ____
2. Identify PLC Data Files usage	BT Buffers: N7 BT Control: BT 27 Work File : N9 Data N: N30 Data F: F31 Data A: A32	BT Buffers: N____ BT Control: BT____ Work File : N____ Data N: N____ Data F: F____ Data A: A____
3. Ladder Logic	Example on disk and in Appendix	
4. Modify Logic for rack position	BTR - Rung 3:0 BTW - Rung 3:2	Modify these cmds as needed per Step 1

5. Modify Logic for Data file usage	N9:0 to N9:10 is used as work space to build pointers	As long as N9 is ok for work file, then should only modify program File 3. Other files are subroutines using indirect addressing
6. Install card in rack	Power down rack and install module	
7. Connect FTA Cable and 24VDC	Connect FTA Cable to module, locking in connector with bail clips. Connect the 24VDC power source to module	
8. Connect instruments to the FTA	Terminate the instrument wires to the FTA.	
9. Apply power to system and place PLC in RUN	Power up rack. Module will begin talking to DE devices as long as BT logic is enabled	

4 Ladder Logic Considerations

4.1 Ladder Logic Overview

Data transfer between the PLC/SLC ladder logic is executed using the standard BTR/BTW Block Transfer commands. In order to transfer the volume of data required to support the application, the ProSoft module 'pages' data through the Block Transfer buffer, allowing a larger volume of data to be written and read between the ladder logic and the module.

In order for the ProSoft Technology module to function, the processor must be in the RUN mode, or in the REM RUN mode. If in any other mode (Fault/PGM), the block transfers between the PLC and the module will stop.

4.2 Block Transferring to the module

Data transfer to the module from the processor is executed through the Block Transfer Write function. The different types of data which are transferred require slightly different data block structures, but the basic data structure is:

Word	Name	Description				
0	BTW Block ID	A block page identifier code. This code is used by the ProSoft module to determine what to do with the data block. Valid codes are: <table border="0" style="margin-left: 20px;"> <tr> <td>BTW Code</td> <td>Description</td> </tr> <tr> <td>1-16</td> <td>DE Channel Write Data Block</td> </tr> </table>	BTW Code	Description	1-16	DE Channel Write Data Block
BTW Code	Description					
1-16	DE Channel Write Data Block					
1 to 63	Data	The data to be written to the module. The structure of the data is dependent on the Block ID code. The following sections provide details on the different structures.				

Although the full physical 64 words of the data buffer may not be used, the BTW lengths must be configured for 64 words, otherwise module operation will be unpredictable.

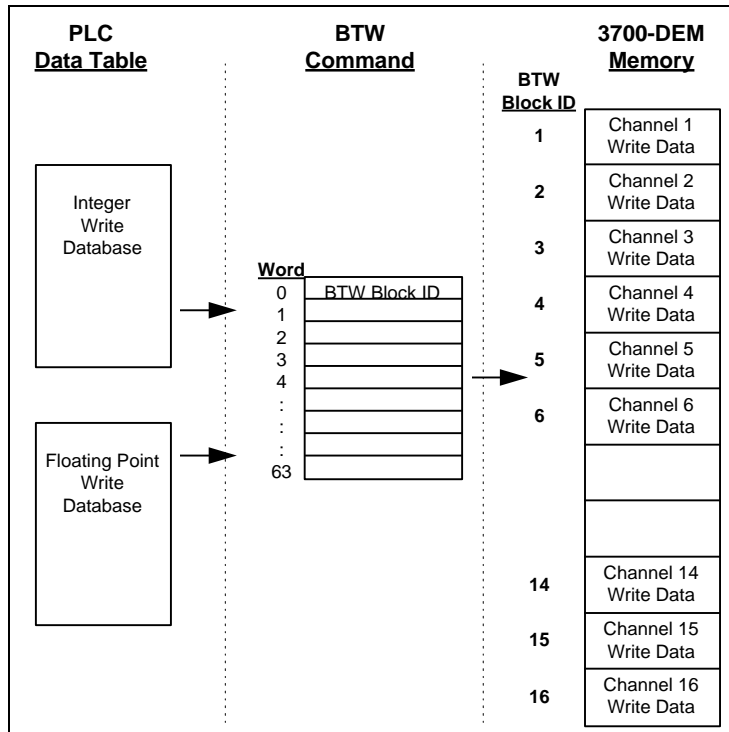

Data transfer from PLC to 3700-DEM : The write database is 'paged' into the DEM module one channel at a time. The channel number being written into corresponds to the BTW Block ID number. The BTW Block ID number is controlled by the DEM module, as discussed in the next section.

4.2.1 DE Channel Write Data Block [BTW Block ID 1-16]

The transfer of the DE Channel Write Data to the module must occur in a fashion that matches the structure expected by the module. The module monitors the BTW Block ID number and decodes the data following it based on this value. The data image transferred from the PLC is moved into the corresponding Channel register space in the 3700-DEM module and is then used as the basis for Data Mismatch comparisons.

Following is the data structure for each of the blocks:

Word	Name	Description										
0	BTW Block ID	This value is used by the module to decode to which DE Channel the following data is being written. Valid codes are: <table border="1"> <thead> <tr> <th>ID</th> <th>Description</th> </tr> </thead> <tbody> <tr> <td>1</td> <td>Channel 1</td> </tr> <tr> <td>2</td> <td>Channel 2</td> </tr> <tr> <td>-</td> <td>-</td> </tr> <tr> <td>16</td> <td>Channel 16</td> </tr> </tbody> </table>	ID	Description	1	Channel 1	2	Channel 2	-	-	16	Channel 16
ID	Description											
1	Channel 1											
2	Channel 2											
-	-											
16	Channel 16											
1	Command Bits	This value is used by the module to determine the write condition for several binary values. These values are as follows: <table border="1"> <thead> <tr> <th>Bits</th> <th>Description</th> </tr> </thead> <tbody> <tr> <td>0</td> <td>cjtact-cold junction compensation</td> </tr> <tr> <td>1</td> <td>piuotcdf-open thermocouple detection</td> </tr> <tr> <td>2</td> <td>freq 50</td> </tr> <tr> <td>3-15</td> <td>Spare</td> </tr> </tbody> </table>	Bits	Description	0	cjtact-cold junction compensation	1	piuotcdf-open thermocouple detection	2	freq 50	3-15	Spare
Bits	Description											
0	cjtact-cold junction compensation											
1	piuotcdf-open thermocouple detection											
2	freq 50											
3-15	Spare											
2 H	Spare											
2 L	Function	This byte value is used by the module to decode the DE command functions to be performed for the DE channel. Valid codes are:										

		<p>Function Description</p> <p>0 Imaging (default value) The database and PV,SV values are being transferred to the 3700 from an instrument on a broadcast basis.</p> <p>1 Download Forces the values received from the PLC to be written to the DE instrument</p> <p>2 Upload Forces the values that have been read from the instrument to be moved into the write locations in the data table. These values will not be written to the instrument until a download command (1) has been issued. The Upload Function is useful for clearing up Data Base Mismatch conditions.</p> <p>The Function value should be reset to Imaging (0) by the PLC logic once the function has been completed.</p>																																												
3 H	DE Config	<p>This byte value controls the DE operation mode for the transmitter configuration, determining what data the transmitter will send to the module. Valid codes are:</p> <p>Function Description</p> <p>0 Analog Mode</p> <p>1 PV Only Mode</p> <p>2 PV and SV Mode</p> <p>3 PV and Config Data Base</p> <p>4 PV, SV and Config Data Base</p> <p>Mode 4 is the recommended DE Config mode</p>																																												
3 L	Damping	<p>This byte value sets the digital filter constant used in the instrument to process the PV value. In the download process, this value is multiplied by three to put it into the correct DE damping parameter value. Valid codes from 0 to 9. Note that the actual damping constants differ between instrument types.</p> <table border="1"> <thead> <tr> <th>Damping</th> <th>SPT</th> <th>STT</th> <th>SFM</th> </tr> </thead> <tbody> <tr><td>0</td><td>0.0</td><td>0.0</td><td>0.0</td></tr> <tr><td>1</td><td>0.16</td><td>0.30</td><td>0.5</td></tr> <tr><td>2</td><td>0.32</td><td>0.70</td><td>1.0</td></tr> <tr><td>3</td><td>0.48</td><td>1.5</td><td>2.0</td></tr> <tr><td>4</td><td>1.0</td><td>3.1</td><td>3.0</td></tr> <tr><td>5</td><td>2.0</td><td>6.3</td><td>4.0</td></tr> <tr><td>6</td><td>4.0</td><td>12.7</td><td>5.0</td></tr> <tr><td>7</td><td>8.0</td><td>25.5</td><td>10.0</td></tr> <tr><td>8</td><td>16.0</td><td>51.1</td><td>50.0</td></tr> <tr><td>9</td><td>32.0</td><td>102.3</td><td>100.0</td></tr> </tbody> </table>	Damping	SPT	STT	SFM	0	0.0	0.0	0.0	1	0.16	0.30	0.5	2	0.32	0.70	1.0	3	0.48	1.5	2.0	4	1.0	3.1	3.0	5	2.0	6.3	4.0	6	4.0	12.7	5.0	7	8.0	25.5	10.0	8	16.0	51.1	50.0	9	32.0	102.3	100.0
Damping	SPT	STT	SFM																																											
0	0.0	0.0	0.0																																											
1	0.16	0.30	0.5																																											
2	0.32	0.70	1.0																																											
3	0.48	1.5	2.0																																											
4	1.0	3.1	3.0																																											
5	2.0	6.3	4.0																																											
6	4.0	12.7	5.0																																											
7	8.0	25.5	10.0																																											
8	16.0	51.1	50.0																																											
9	32.0	102.3	100.0																																											
4 H	PV Characterization	<p>This byte value determines the algorithm used in the transmitter for process variable characterization. The PV Characterization value chosen must be valid for the transmitter. The value is <u>not</u> checked prior to transfer to the DE processor.</p>																																												
4 L	Sensor Type	<p>Value indicates the type of instrument which is connected to the DE Channel. Special consideration must be given for multi-variable transmitters (to be defined in future). Possible values are:</p> <table border="1"> <thead> <tr> <th>Value</th> <th>Hex</th> <th>Description</th> </tr> </thead> <tbody> <tr><td>8</td><td>8</td><td>SPT DP</td></tr> <tr><td>9</td><td>9</td><td>SPT GP</td></tr> <tr><td>10</td><td>A</td><td>SPT AP</td></tr> <tr><td>11</td><td>B</td><td>STT</td></tr> <tr><td>12</td><td>C</td><td>SFM</td></tr> <tr><td>13</td><td>D</td><td>SCM</td></tr> <tr><td>14</td><td>E</td><td>SGC</td></tr> <tr><td>15</td><td>F</td><td>SVP</td></tr> <tr><td>16</td><td>10</td><td>MTT</td></tr> <tr><td>17</td><td>11</td><td>STP</td></tr> <tr><td>18</td><td>12</td><td>SLV</td></tr> <tr><td>19</td><td>13</td><td>SDU</td></tr> </tbody> </table>	Value	Hex	Description	8	8	SPT DP	9	9	SPT GP	10	A	SPT AP	11	B	STT	12	C	SFM	13	D	SCM	14	E	SGC	15	F	SVP	16	10	MTT	17	11	STP	18	12	SLV	19	13	SDU					
Value	Hex	Description																																												
8	8	SPT DP																																												
9	9	SPT GP																																												
10	A	SPT AP																																												
11	B	STT																																												
12	C	SFM																																												
13	D	SCM																																												
14	E	SGC																																												
15	F	SVP																																												
16	10	MTT																																												
17	11	STP																																												
18	12	SLV																																												
19	13	SDU																																												

		20 14 Generic
5 H	PV Number	In a multi-variable transmitter, this value indicates the relative number of the PV value coming from the instrument. Used in combination with Number of PV value in low byte. In a single variable instrument, this will have a value of 1.
5 L	Number of PVs	Indicates the total number of PV values to be returned from the instrument. This value will be 1 in a single variable instrument and could be up to 4 in an MV instrument.
6-9	Tag Name	This string of 8 ASCII characters is used to identify the instrument in the system. The Tag Name must be unique for every physical transmitter on a module (ie., every channel of a multivariable transmitter must be the same Tag Name)
10	Spare	
11,12	LRV (float)	This floating point value is used to calculate the instrument's LRV using the equation: $Instrument\ LRV = LRV / URL$
13,14	URV (float)	This floating point value is used to calculate the instrument's Span using the equation: $Instrument\ Span = (URV - LRV) / URL$
15,16	URL (float)	Upper Range Limit. This value is used by the DEM module for Mismatch comparison purposes only. It is not written to the instrument during a Download
17,18	Damping(float) (Future)	This value is the floating point representation of the damping factor. When the byte value of Damping is 7Eh, the DE CPU is returning the value in floating point format (future)
19,20	Spare(float)	

4.3 Block Transferring data from the module

Data transfer from the module to the processor is executed through the Block Transfer Read function. The different types of data which are transferred require slightly different data block structures, but the basic data structure is:

Word	Name	Description								
0	BTR Block ID	A block page identifier code. This code is used by the ladder logic to determine what to do with the data block. Valid codes are: <table border="1" style="margin-left: 20px;"> <thead> <tr> <th>BTR Code</th> <th>Description</th> </tr> </thead> <tbody> <tr> <td>0</td> <td>Module Real Time Data</td> </tr> <tr> <td>1-16</td> <td>Channel Config Database - Int/Float</td> </tr> <tr> <td>17-32</td> <td>Channel Config Database - ASCII</td> </tr> </tbody> </table> The module will automatically scroll through the BTR Block ID numbers, alternating between 0 and a value from 1-32. In this fashion, the Module Real Time data is updated every other BTR command.	BTR Code	Description	0	Module Real Time Data	1-16	Channel Config Database - Int/Float	17-32	Channel Config Database - ASCII
BTR Code	Description									
0	Module Real Time Data									
1-16	Channel Config Database - Int/Float									
17-32	Channel Config Database - ASCII									
1	BTW Block ID	This is the value which the ladder logic uses to setup the next BTW instruction.								
2 to 63	Data	The data to be transferred from the module to the data table in the PLC. The structure of the data is dependent on the Block ID code. The following sections provide details on the different structures.								

Although the full physical 64 words of the data buffer may not be used, the BTR length must be configured for 64 words, otherwise module operation will be unpredictable.

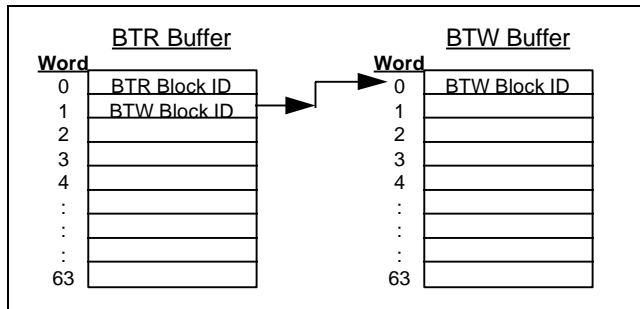

Setting up the BTW Block ID Number : This transfer occurs during every BTR command cycle and is the means by which the module controls and increments the data written to the module.

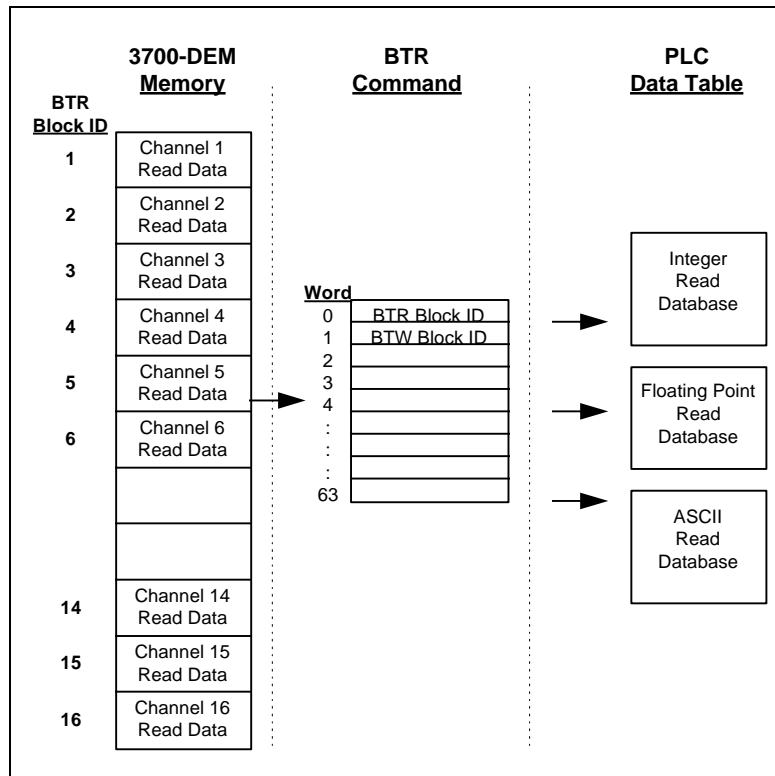

Data Transfer from 3700-DEM to PLC : The database data received from the DE instruments is transferred back to the ladder logic data table memory in 'pages'. Each page represents one input Channel on the module. The structure of the BTR Buffer is detailed in the Appendix and in the following discussion.

4.3.1 Module Real Time Data [BTR Block ID 0]

The 3700-DEM module returns the module status and real time PV and SV results in the BTR Block ID 0. The structure of BTR buffer is as follows:

Word	Name	Description						
0	BTR Block ID	The page identifier code. During the Real Time Data update this value will be zero(0)						
1	BTW Block ID	This value is used by the ladder logic to setup the next BTW instruction to the module. Valid codes are: <table border="1" style="margin-left: 20px;"> <thead> <tr> <th>ID</th> <th>Description</th> </tr> </thead> <tbody> <tr> <td>1</td> <td>Channel 1</td> </tr> <tr> <td>2</td> <td>Channel 2</td> </tr> </tbody> </table>	ID	Description	1	Channel 1	2	Channel 2
ID	Description							
1	Channel 1							
2	Channel 2							

		- - 16 Channel 16												
2	Module Status	<p>This value represents the operating status of the module. Expected status codes are:</p> <table border="1"> <thead> <tr> <th>Code</th> <th>Description</th> </tr> </thead> <tbody> <tr> <td>0</td> <td>All OK</td> </tr> <tr> <td>1</td> <td>DE CPU Init Error</td> </tr> <tr> <td>2</td> <td>DE CPU Reset Error</td> </tr> <tr> <td>3</td> <td>DE Timeout Error</td> </tr> <tr> <td>5</td> <td>FTA Not Connected</td> </tr> </tbody> </table> <p>If Status Codes 1-3 are received, the module has detected a failure condition in at least one of the DE processors. To recover and re-initialized the module, press the Reset P/B at the top of the 3700 module.</p> <p>If Status Code 5 is received, the module has determined that the FTA is not connected. Verify the connection and plug back in. The module will clear the error condition itself and continue operation once the FTA is reconnected.</p>	Code	Description	0	All OK	1	DE CPU Init Error	2	DE CPU Reset Error	3	DE Timeout Error	5	FTA Not Connected
Code	Description													
0	All OK													
1	DE CPU Init Error													
2	DE CPU Reset Error													
3	DE Timeout Error													
5	FTA Not Connected													
3	Data Type ID	<p>This value is used by the ladder logic to decode the type of floating point values which follow in the the data block. The Data Type is bit encoded to ease the programming.</p> <table border="1"> <thead> <tr> <th>Bit</th> <th>Description</th> </tr> </thead> <tbody> <tr> <td>0</td> <td>PV Update - Last Good Values</td> </tr> <tr> <td>1</td> <td>SV Update - Last Good Values</td> </tr> <tr> <td>2</td> <td>PV Update - NaN Values</td> </tr> <tr> <td>3</td> <td>SV Update - NaN Values</td> </tr> </tbody> </table> <p>The 'Last Good Values' data values are not impacted by the integrity checking algorithms of the 3700 module. The 'NaN Values' data values represent the results of the PV and SV values conditioned by the integrity checking of the module. Included in the verification process are:</p> <ul style="list-style-type: none"> - FTA Presence - Data Base Mismatch - PV Update Timeout - SFC Write Detected 	Bit	Description	0	PV Update - Last Good Values	1	SV Update - Last Good Values	2	PV Update - NaN Values	3	SV Update - NaN Values		
Bit	Description													
0	PV Update - Last Good Values													
1	SV Update - Last Good Values													
2	PV Update - NaN Values													
3	SV Update - NaN Values													
4	Update Status	<p>This is a bit encoded word which ladder may use to condition the movement of data from the module to the data table. Each bit, representing a DE Channel, is set when a value has been read from the instrument, or when the module is overriding the value as a result of the data verification process (i.e., sending a NaN value).</p>												
5 to 36	PV/SV Values (float)	<p>These sixteen floating point values contain the image of the respective data registers in the module. The movement of these values to the data table may be conditioned on the Update Status Word. The PV and the SV values are presented in Engineering Units. The PV EU value is calculated based on the URV and LRV values in the instrument data base, therefore the PV value is not updated to the PLC until after the Configuration Data Base has been received from the instrument at least once (approximately 15-90 seconds after power up or reset of the module).</p>												
50,51	Product Name	<p>These two words represent the product name of the module in an ASCII representation. In the case of the 3700 product, the letters 'DEM ' should be displayed when placing the programming software in the ASCII data representation mode.</p>												
52,53	Product Revision	<p>These two words represent the product revision level of the firmware in an ASCII representation. An example of the data displayed would be '1.00' when placing the programming software in the ASCII data representation mode.</p>												
54	Product Operating System	<p>This word represent the module's internal operating system revision level in an ASCII representation.</p>												
55	Product Run Number	<p>This number represents the 'batch' number that your particular chip belongs to in an ASCII representation.</p>												

4.3.2 Channel Configuration Data - Integer/Float [BTR Block ID 1 to 16]

The 3700-DEM module returns the Integer and Floating Point values of the Configuration database for each DE channel in BTR Blocks 1-16. The structure of BTR buffer is as follows:

Word	Name	Description																																
0	BTR Block ID	The page identifier code. The transfer of Channel Configuration Data Block will be active when the BTR Block ID is between 1-16.																																
1	BTW Block ID	This value is used by the ladder logic to setup the next BTW instruction to the module. Valid codes are: <table border="1"> <thead> <tr> <th>ID</th> <th>Description</th> </tr> </thead> <tbody> <tr> <td>1</td> <td>Channel 1</td> </tr> <tr> <td>2</td> <td>Channel 2</td> </tr> <tr> <td>-</td> <td>-</td> </tr> <tr> <td>16</td> <td>Channel 16</td> </tr> </tbody> </table>	ID	Description	1	Channel 1	2	Channel 2	-	-	16	Channel 16																						
ID	Description																																	
1	Channel 1																																	
2	Channel 2																																	
-	-																																	
16	Channel 16																																	
2	Integer Data Pointer	This value can be used by the ladder logic to build an Indirect Address pointer into the Integer data file. The module presumes a starting offset of 3 when building the pointer. The expected pointer values are: <table border="1"> <thead> <tr> <th>Blk ID</th> <th>Ptr</th> <th>Description</th> </tr> </thead> <tbody> <tr> <td>1</td> <td>3</td> <td>Channel 1</td> </tr> <tr> <td>2</td> <td>18</td> <td>Channel 2</td> </tr> <tr> <td>3</td> <td>33</td> <td>Channel 3</td> </tr> <tr> <td>-</td> <td>-</td> <td>Increments of 15</td> </tr> <tr> <td>16</td> <td>228</td> <td>Channel 16</td> </tr> </tbody> </table>	Blk ID	Ptr	Description	1	3	Channel 1	2	18	Channel 2	3	33	Channel 3	-	-	Increments of 15	16	228	Channel 16														
Blk ID	Ptr	Description																																
1	3	Channel 1																																
2	18	Channel 2																																
3	33	Channel 3																																
-	-	Increments of 15																																
16	228	Channel 16																																
3	Floating Point Data Pointer	This value can be used by the ladder logic to build an Indirect Address pointer into the Floating Point Read Data portion of the Floating Point data file. The module presumes a starting offset of 64 when building the pointer. The expected pointer values are: <table border="1"> <thead> <tr> <th>Blk ID</th> <th>Ptr</th> <th>Description</th> </tr> </thead> <tbody> <tr> <td>1</td> <td>64</td> <td>Channel 1</td> </tr> <tr> <td>2</td> <td>71</td> <td>Channel 2</td> </tr> <tr> <td>3</td> <td>78</td> <td>Channel 3</td> </tr> <tr> <td>-</td> <td>-</td> <td>Increments of 7</td> </tr> <tr> <td>16</td> <td>169</td> <td>Channel 16</td> </tr> </tbody> </table>	Blk ID	Ptr	Description	1	64	Channel 1	2	71	Channel 2	3	78	Channel 3	-	-	Increments of 7	16	169	Channel 16														
Blk ID	Ptr	Description																																
1	64	Channel 1																																
2	71	Channel 2																																
3	78	Channel 3																																
-	-	Increments of 7																																
16	169	Channel 16																																
4	Device Status Flags #1	The bits in this word are used to indicate the current operations status of the data collection for the Channel. When the bit is set (1) the variable active <table border="1"> <tbody> <tr><td>0</td><td>Function Done</td></tr> <tr><td>1</td><td>Function Passed</td></tr> <tr><td>2</td><td>PV Update Flag - Toggle</td></tr> <tr><td>3</td><td>PV Output</td></tr> <tr><td>4</td><td>SFC Detected</td></tr> <tr><td>5</td><td>SV Update Flag - Toggle</td></tr> <tr><td>6</td><td>CFG Data Base Update - Toggle</td></tr> <tr><td>7</td><td>Spare</td></tr> <tr><td>8</td><td>Cold Junction Reference</td></tr> <tr><td>9</td><td>Open Thermocouple Detection</td></tr> <tr><td>10</td><td>Freq 50</td></tr> <tr><td>11</td><td>Data Mismatch Active Flag</td></tr> <tr><td>12</td><td>Spare</td></tr> <tr><td>13</td><td>Bad PV Flag</td></tr> <tr><td>14</td><td>PV Under Range flag</td></tr> <tr><td>15</td><td>PV Over Range flag</td></tr> </tbody> </table>	0	Function Done	1	Function Passed	2	PV Update Flag - Toggle	3	PV Output	4	SFC Detected	5	SV Update Flag - Toggle	6	CFG Data Base Update - Toggle	7	Spare	8	Cold Junction Reference	9	Open Thermocouple Detection	10	Freq 50	11	Data Mismatch Active Flag	12	Spare	13	Bad PV Flag	14	PV Under Range flag	15	PV Over Range flag
0	Function Done																																	
1	Function Passed																																	
2	PV Update Flag - Toggle																																	
3	PV Output																																	
4	SFC Detected																																	
5	SV Update Flag - Toggle																																	
6	CFG Data Base Update - Toggle																																	
7	Spare																																	
8	Cold Junction Reference																																	
9	Open Thermocouple Detection																																	
10	Freq 50																																	
11	Data Mismatch Active Flag																																	
12	Spare																																	
13	Bad PV Flag																																	
14	PV Under Range flag																																	
15	PV Over Range flag																																	
5	Device Status Flags #2	The bits in this word are used to indicate the current mismatch status for each data variable which is verified. When the bit is set (1) the variable is in a mis-matched condition. <table border="1"> <thead> <tr> <th>Bit</th> <th>Description</th> </tr> </thead> <tbody> <tr> <td>0</td> <td>Mismatch - URL</td> </tr> <tr> <td>1</td> <td>Mismatch - LRV</td> </tr> <tr> <td>2</td> <td>Mismatch - URV</td> </tr> <tr> <td>3</td> <td>Mismatch - Damping</td> </tr> </tbody> </table>	Bit	Description	0	Mismatch - URL	1	Mismatch - LRV	2	Mismatch - URV	3	Mismatch - Damping																						
Bit	Description																																	
0	Mismatch - URL																																	
1	Mismatch - LRV																																	
2	Mismatch - URV																																	
3	Mismatch - Damping																																	

		4 Mismatch - DE Configuration 5 Mismatch - PV Characterization 6 Mismatch - Sensor Type 7 Mismatch - Tag ID 8 Mismatch - PV Number 9 Mismatch - Number of PV Values 10 Mismatch - Cold Junction Reference 11 Mismatch - Open Thermo Couple Detection 12 Mismatch - Freq 50 13-15 Spare bits																		
6 H	Special DB byte	A byte value returned from the DE CPU which is bit mapped with the following status information: <table border="1"> <thead> <tr> <th>Bit</th> <th>Description</th> </tr> </thead> <tbody> <tr> <td>0</td> <td>Initial Power-up Data base</td> </tr> <tr> <td>1</td> <td>1st DB capture in progress</td> </tr> <tr> <td>2</td> <td>4 byte data base</td> </tr> <tr> <td>3</td> <td>No DE Data Available</td> </tr> <tr> <td>4</td> <td>SFC Hit</td> </tr> <tr> <td>5</td> <td>Output Mode</td> </tr> <tr> <td>6</td> <td>Not Used</td> </tr> <tr> <td>7</td> <td>Not Used</td> </tr> </tbody> </table>	Bit	Description	0	Initial Power-up Data base	1	1st DB capture in progress	2	4 byte data base	3	No DE Data Available	4	SFC Hit	5	Output Mode	6	Not Used	7	Not Used
Bit	Description																			
0	Initial Power-up Data base																			
1	1st DB capture in progress																			
2	4 byte data base																			
3	No DE Data Available																			
4	SFC Hit																			
5	Output Mode																			
6	Not Used																			
7	Not Used																			
6 L	Status Bits 1	To be defined by Honeywell																		
7 H	Status Bits 2	To be defined by Honeywell																		
7 L	Status Bits 3	To be defined by Honeywell																		
8	Spare																			
9	PV Value 0 to 4095	An integer value representing 0 to 100% of span for the PV value being returned from the instrument.																		
10 H	CFG database update counter	A byte value returned from the DE CPU. This value represents the number of times the entire configuration database has been acquired from the instrument since reset. This counter will rollover at 255																		
10 L	Communication error counter	A byte value returned from the DE CPU. This value represents the number of DE communication errors since reset. This counter will rollover at 255																		
11 H	PV updated counter	A byte value returned from the DE CPU. This value represents the number of times the PV value has been acquired since reset. This counter will rollover at 255																		
11 L	SV updated counter	A byte value returned from the DE CPU. This value represents the number of times the SV value has been acquired from the instrument since reset. This counter will rollover at 255																		
12 H	Spare																			
12 L	Function	This byte value is used by the module to decode the DE command functions to be performed for the DE channel. Valid codes are: <table border="1"> <thead> <tr> <th>Function</th> <th>Description</th> </tr> </thead> <tbody> <tr> <td>0</td> <td>Imaging (default value) The database and PV,SV values are being transferred to the 3700 on a broadcast</td> </tr> <tr> <td>1</td> <td>Download Forces the values received from the PLC to be written to the DE instrument</td> </tr> <tr> <td>2</td> <td>Upload Forces the values that have been read from the instrument to be moved into the write locations in the data table. These values will not be written to the instrument until a download command (1) has been issued. The Upload Function is useful for clearing up Data Base Mismatch conditions.</td> </tr> </tbody> </table> The Function value should be reset to Imaging (0) by the PLC logic once the function has been completed.	Function	Description	0	Imaging (default value) The database and PV,SV values are being transferred to the 3700 on a broadcast	1	Download Forces the values received from the PLC to be written to the DE instrument	2	Upload Forces the values that have been read from the instrument to be moved into the write locations in the data table. These values will not be written to the instrument until a download command (1) has been issued. The Upload Function is useful for clearing up Data Base Mismatch conditions.										
Function	Description																			
0	Imaging (default value) The database and PV,SV values are being transferred to the 3700 on a broadcast																			
1	Download Forces the values received from the PLC to be written to the DE instrument																			
2	Upload Forces the values that have been read from the instrument to be moved into the write locations in the data table. These values will not be written to the instrument until a download command (1) has been issued. The Upload Function is useful for clearing up Data Base Mismatch conditions.																			
13 H	DE cfg - Operational Mode	This byte value controls the DE operation mode for the transmitter configuration, determining what data the transmitter will send to the module. Valid codes are:																		

		Function	Description																																												
		0 1 2 3 4	Analog Mode PV Only Mode PV and SV Mode PV and Config Data Base PV, SV and Config Data Base																																												
13 L	Damping		<p>This byte value sets the digital filter constant used in the instrument to process the PV value. In the download process, this value is multiplied by three to put it into the correct DE damping parameter value. Valid codes from 0 to 9. Note that the actual damping constants differ between instrument types.</p> <table border="1"> <thead> <tr> <th>Damping</th> <th>SPT</th> <th>STT</th> <th>SFM</th> </tr> </thead> <tbody> <tr><td>0</td><td>0.0</td><td>0.0</td><td>0.0</td></tr> <tr><td>1</td><td>0.16</td><td>0.30</td><td>0.5</td></tr> <tr><td>2</td><td>0.32</td><td>0.70</td><td>1.0</td></tr> <tr><td>3</td><td>0.48</td><td>1.5</td><td>2.0</td></tr> <tr><td>4</td><td>1.0</td><td>3.1</td><td>3.0</td></tr> <tr><td>5</td><td>2.0</td><td>6.3</td><td>4.0</td></tr> <tr><td>6</td><td>4.0</td><td>12.7</td><td>5.0</td></tr> <tr><td>7</td><td>8.0</td><td>25.5</td><td>10.0</td></tr> <tr><td>8</td><td>16.0</td><td>51.1</td><td>50.0</td></tr> <tr><td>9</td><td>32.0</td><td>102.3</td><td>100.0</td></tr> </tbody> </table>	Damping	SPT	STT	SFM	0	0.0	0.0	0.0	1	0.16	0.30	0.5	2	0.32	0.70	1.0	3	0.48	1.5	2.0	4	1.0	3.1	3.0	5	2.0	6.3	4.0	6	4.0	12.7	5.0	7	8.0	25.5	10.0	8	16.0	51.1	50.0	9	32.0	102.3	100.0
Damping	SPT	STT	SFM																																												
0	0.0	0.0	0.0																																												
1	0.16	0.30	0.5																																												
2	0.32	0.70	1.0																																												
3	0.48	1.5	2.0																																												
4	1.0	3.1	3.0																																												
5	2.0	6.3	4.0																																												
6	4.0	12.7	5.0																																												
7	8.0	25.5	10.0																																												
8	16.0	51.1	50.0																																												
9	32.0	102.3	100.0																																												
14 H	PV Characterization		This byte value determines the algorithm used in the transmitter for process variable characterization. The PV Characterization value chosen must be valid for the transmitter. The value is <u>not</u> checked prior to transfer to the DE processor.																																												
14 L	Sensor Type		<p>Value indicates the type of instrument which is connected to the DE Channel. Special consideration must be given for multi-variable transmitters (to be defined in future). Possible values are:</p> <table border="1"> <thead> <tr> <th>Value</th> <th>Hex</th> <th>Description</th> </tr> </thead> <tbody> <tr><td>8</td><td>8</td><td>SPT DP</td></tr> <tr><td>9</td><td>9</td><td>SPT GP</td></tr> <tr><td>10</td><td>A</td><td>SPT AP</td></tr> <tr><td>11</td><td>B</td><td>STT</td></tr> <tr><td>12</td><td>C</td><td>SFM</td></tr> <tr><td>13</td><td>D</td><td>SCM</td></tr> <tr><td>14</td><td>E</td><td>SGC</td></tr> <tr><td>15</td><td>F</td><td>SVP</td></tr> <tr><td>16</td><td>10</td><td>MTT</td></tr> <tr><td>17</td><td>11</td><td>STP</td></tr> <tr><td>18</td><td>12</td><td>SLV</td></tr> <tr><td>19</td><td>13</td><td>SDU</td></tr> <tr><td>20</td><td>14</td><td>Generic</td></tr> </tbody> </table>	Value	Hex	Description	8	8	SPT DP	9	9	SPT GP	10	A	SPT AP	11	B	STT	12	C	SFM	13	D	SCM	14	E	SGC	15	F	SVP	16	10	MTT	17	11	STP	18	12	SLV	19	13	SDU	20	14	Generic		
Value	Hex	Description																																													
8	8	SPT DP																																													
9	9	SPT GP																																													
10	A	SPT AP																																													
11	B	STT																																													
12	C	SFM																																													
13	D	SCM																																													
14	E	SGC																																													
15	F	SVP																																													
16	10	MTT																																													
17	11	STP																																													
18	12	SLV																																													
19	13	SDU																																													
20	14	Generic																																													
15 H	PV Number		In a multi-variable transmitter, this value indicates the relative number of the PV value coming from the instrument. Used in combination with Number of PV value in low byte. In a single variable instrument, this will have a value of 1.																																												
15 L	Number of PVs		Indicates the total number of PV values to be returned from the instrument. This value will be 1 in a single variable instrument and could be up to 4 in an MV instrument.																																												
16,17,18	Spare																																														
19,20	LRV		Lower Range Value on the transmitter PV value																																												
21,22	URV		Upper Range Value on the transmitter PV value																																												
23,24	URL		Upper Range Limit on the transmitter PV value																																												
25,26	Damping		This value is the floating point representation of the damping factor.																																												
27,28	LRL		Lower Range Limit on the transmitter PV value. This is a read only parameter																																												
29 - 32	Spare																																														

4.3.3 Channel Configuration Data - ASCII [BTR Block ID 17 to 32]

The 3700-DEM module returns the ASCII values of the Configuration database for each DE channel in BTR Blocks 17-326. The structure of BTR buffer is as follows:

Word	Name	Description																		
0	BTR Block ID	The page identifier code. The transfer of Channel ASCII Configuration Data Block will be active when the BTR Block ID is between 17 and 32.																		
1	BTW Block ID	This value is used by the ladder logic to setup the next BTW instruction to the module. Valid codes are: <table border="1"> <thead> <tr> <th>ID</th> <th>Description</th> </tr> </thead> <tbody> <tr> <td>1</td> <td>Channel 1</td> </tr> <tr> <td>2</td> <td>Channel 2</td> </tr> <tr> <td>-</td> <td>-</td> </tr> <tr> <td>16</td> <td>Channel 16</td> </tr> </tbody> </table>	ID	Description	1	Channel 1	2	Channel 2	-	-	16	Channel 16								
ID	Description																			
1	Channel 1																			
2	Channel 2																			
-	-																			
16	Channel 16																			
2	ASCII Data Pointer	This value can be used by the ladder logic to build an Indirect Address pointer into the ASCII data file. The module presumes a starting offset of 0 when building the pointer. The expected pointer values are: <table border="1"> <thead> <tr> <th>Blk ID</th> <th>Ptr</th> <th>Description</th> </tr> </thead> <tbody> <tr> <td>1</td> <td>0</td> <td>Channel 1</td> </tr> <tr> <td>2</td> <td>60</td> <td>Channel 2</td> </tr> <tr> <td>3</td> <td>120</td> <td>Channel 3</td> </tr> <tr> <td>-</td> <td>-</td> <td>Increments of 60</td> </tr> <tr> <td>16</td> <td>900</td> <td>Channel 16</td> </tr> </tbody> </table>	Blk ID	Ptr	Description	1	0	Channel 1	2	60	Channel 2	3	120	Channel 3	-	-	Increments of 60	16	900	Channel 16
Blk ID	Ptr	Description																		
1	0	Channel 1																		
2	60	Channel 2																		
3	120	Channel 3																		
-	-	Increments of 60																		
16	900	Channel 16																		
3-7	Tag Name	ASCII string containing the Tag Name used to identify the transmitter to the system. The Tag Name must be unique for every physical transmitter on a module (ie., every channel of a multivariable transmitter must be the same Tag Name)																		
8-11	Serial Number	ASCII string representing the transmitter Serial Number. This is a transmitter parameter that is read only from the instrument to the DEM module																		
12-15	Software Revision	ASCII string containing the firmware revision level of the transmitter. This is a transmitter parameter that is read only from the instrument to the DEM module																		
16-31	Scratch Pad	ASCII string containing the transmitter's scratch pad. This is a transmitter parameter that is read only from the instrument to the DEM module																		
32-63	Transmitter Status	ASCII string containing the transmitter's detailed status. This is a transmitter parameter that is read only from the instrument to the DEM module																		

5 Hardware Diagnostics

Several hardware diagnostics capabilities have been implemented using the LED indicator lights on the front of the module. The following sections explain the meaning of the individual LEDs on the module.

5.1 Normal Operation of Module (Fault LED Off)

Under normal operating conditions, the LEDs will indicate the module's operating status:

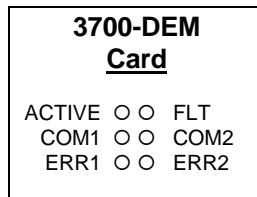

Table 5.1 : Normal Operating LED Indication (Fault LED off)

ProSoft Module	Color	Status	Indication
ACT	Green	Blink (Fast)	<u>Normal state</u> : The module is successfully Block Transferring with the PLC
		On/Off	The module is attempting to Block Transfer with the PLC and has failed. The PLC may be in the PGM mode or may be faulted
FLT	Red	Off	<u>Normal State</u> : No system problems are detected during background diagnostics
		On	A system problem was detected during background diagnostics. Please see the next Section of this manual or contact the Factory for assistance
COM1/2	Green		<u>DE CPU 1 and 2 Communication Status</u> Each LED is associated with one of the DE communication processors. COM1 is used to annunciate DE Channels 1-8, while COM2 is used to annunciate DE Channels 9-16
		Blink	This light blinks every time a valid PV variable is received from an instrument on one of the 8 DE channels annunciated by the LED
ERR1 ERR2	Amber	Off	<u>Normal State</u> : When the error LED is off and the related port is actively transferring data, there are no communication errors
		Blink	Periodic communication errors are occurring during data communications. The conditions which will cause the LED to blink are: <ul style="list-style-type: none"> • Download Fail • Data Base Mismatch on at least one channel/parameter
		On	This LED will stay on under several conditions: <u>Only one LED on:</u> <ul style="list-style-type: none"> • No defined conditions <u>Both LEDs on:</u> <ul style="list-style-type: none"> • FTA not Connected • Loss of 24 VDC power to module

5.2 Faulted Status of Module (Fault LED On)

Should the DEM fail during operation, this condition will be indicated visually on the LEDs on front of the module.

Although there are many possible detailed conditions which can cause the module to fault, they all come down to the fact that the main micro on the DEM has failed to communicate with one or both of the DE Communication processors.

Normally this condition is indicative of a hardware problem, possibly a failure, but it may also indicate that the DE CPU failed due to erroneous data being received either from the PLC or from the instrument.

Although the exact cause of the fault condition should be determined from the Module Status value in the data table, the LEDs on the front of the module will also indicate some status.

5.2.1 DE Init Error

ACTIVE ○ ●	FLT	The module is in a faulted condition. This indicates that the main CPU on the DEM has failed to communicate successfully with one or both of the DE processors.
COM1 ○ ○	COM2	
ERR1 ○ ●	ERR2	

5.2.2 DE Reset Error

ACTIVE FLT
COM1 COM2
ERR1 ERR2

The module is in a faulted condition. This indicates that one or more of the 6811 DE CPU processors has failed to Reset properly during initialization. Try resetting the module again. Call the Factory if all else fails.

5.2.3 DE Timeout Error

ACTIVE FLT
COM1 COM2
ERR1 ERR2

The module is in a faulted condition. This indicates that one or more of the 6811 DE CPU processors has not returned control of the Shared RAM in the proper timeframe. Try resetting the module. Call the factory if all else fails.

5.3 Clearing a Fault Condition

To clear a fault condition, verify the data being transferred from the PLC, then press the reset pushbutton at the top of the module.

During the power up and initialization of the module, the health of the two DE Communication processors is verified. If there is a hardware problem, it should be detected at this time and annunciated on the LEDs.

If the condition does not clear, contact the factory with the LED status information.

Appendix

A Detailed Honeywell DE Parameter Descriptions

Provides a detailed description of the parameters coming from and going to the DE instruments

B Honeywell SCAN 3000 DEM Interface Data Table

This section contains the details associated with the memory and data structure expected by the SCAN 3000 system. The SCAN 3000 system is expecting a PLC data table layout consisting of three contiguous data files, each containing the data outlined in Appendix A. The files should be created in the following order:

N	Integer File
F	Floating Point File
A	ASCII file

These files can be located anywhere in memory, but they must be contiguous and in this order. A set of these three files must be created per DEM module supported by the PLC

C 3700-DEM BTR and BTW Block Transfer Buffers

This section details the mapping of the data in the BTR and BTW buffers when exchanging data with the 3700-DEM module.

D FTA Connection

E Support, Service and Warranty

F Example PLC 5 Ladder Logic

The PLC 5 example ladder logic provided as part of the manual and on disk (A-B 6200 software format) supports the SCAN 3000 Interface data structure outlined in Appendix A.

If your application does not have a need to support the full SCAN 3000 memory map, then the ladder logic can be greatly simplified. Please contact the factory for a copy of any examples that may be available.

Appendix A
Detailed Honeywell DE Parameter Descriptions

Device Status Flags #1

Bit	Name	Description
0	Function Done	0 = Not complete, 1 = Complete Status Flag associated with the function parameter. When the Function parameter is set to one(1) to initiate a database write to the instrument, this bit may be monitored to determine completion
1	Function Passed	0 = Function Failed, 1 = Function Passed Flag to be used in conjunction with Function Done Flag. When the Function Command is set to anything besides Imaging PV, the Function Done Flag is set False, When the requested Function Command is completed, the 3700 will return to the Imaging PV mode, set the Function Done Flag to 1 and set the Function Passed depending on the outcome of the command. Note that if a Download to an Instrument is initiated and no parameters have been changed in the database, the Function Passed Flag will <u>not</u> be set.
2	PV Update Flag (Toggles)	This flag indicates that the DEM has received a new PV value from the instrument in this DE Channel. This flag will be toggled during the next Block Transfer with the current BTR Block ID number, unless a new PV value is received again.
3	PV Output	This flag indicates that the PV is in Output Mode. In this implementation the instrument can only be placed in Output Mode by the SFC (hand held) In this mode, the PV is forced to a value which overrides the transmitter PV. This is a read only value
4	SFC Detected	This flag indicates that the DE CPU has detected that the SFC has changed transmitter parameters. This bit is for status indication only in the PLC but is used by the DEM as part of the parameter mismatch logic.
5	SV Updated Flag (Toggles)	This flag indicates that the DEM has received a new SV value from the instrument in this DE Channel. This flag will be toggled during the next Block Transfer with the current BTR Block ID number, unless a new SV value is received again.
6	Config Data Base Update (Toggles)	This flag indicates that the DEM has received a new Configuration Data Base from the DE CPU. This flag will only be updated by the DE CPU when the complete data base has been received from the instrument. be toggled during the next Block Transfer with the current BTR Block ID number.
7	Spare	
8	Cold Junction Ref	A flag indicating if cold junction reference is being used by the transmitter. This value may be changed in the instrument by the PLC via the Download Function. 0 External reference used 1 Internal (to transmitter) reference is used
9	Open Thermocouple Detect	A flag indicating if Open Thermocouple Detection is enabled in the transmitter. This value may be changed in the instrument by the PLC via the Download Function. 0 Detection Not Enabled 1 Detection Enabled
10	Freq 50	A flag indicating if 50 or 60 Hertz filtering is being used in the transmitter. This value may be changed in the instrument by the PLC via the Download Function(VERIFY THIS). 0 60 Hz 1 50 Hz
11	Data Mismatch Active Flag	A flag set by the DEM whenever an active data base mis-match condition exists. The exact mis-matched parameters can be determined by checking Device Status Flags #2. The Data Mismatch flag will be cleared by the DEM whenever the condition causing the mis-match is cleared. 0 No mis-match condition 1 Mis-match condition
12	Spare	
13	Bad PV Flag	A flag set by the DEM whenever the PV value is suspected or known to be bad. Once the PV value is good again, this flag will be cleared

		<p>by the DEM. Conditions causing this flag to be set include:</p> <p><u>PV Update Timeout</u> : If the PV value has not been updated within the timeout period, the flag is set</p> <p><u>FTA Not Present</u> : If the FTA connector or the 24 VDC power supply is disconnected, the flag will be set</p> <p><u>SFC Write Detected</u> : If and SFC write to the instrument data base is detected, the flag will be set. Note that in a redundant application, the SFC Write Detected condition will be detected when a Download command is executed from the other module or from the SFC unit.</p> <p><u>Database Mismatch</u> : If the data base mismatch condition is detected, the flag will be set</p>
14	PV Under Range Flag	This flag is set whenever the PV value is under 0%.
15	PV Over Range Flag	This flag is set whenever the PV value is over 100%.

Device Status Flags #2

The bits in this word are used to indicate the current mis-match status for each data variable which is verified. When the bit is set (1) the variable is in a mis-matched condition. The mis-match may be cleared by performing a download to the instrument or by performing an upload (copying the read data base to the write data base). If the PLC data base is downloaded to the instrument, the mis-match condition will not clear until the complete data base has been read back from the instrument.

Bit	Description
0	URL - Mismatch
1	LRV - Mismatch
2	URV - Mismatch
3	Damping - Mismatch
4	DE Config - Mismatch
5	PV Char - Mismatch
6	Sensor Type - Mismatch
7	Tag ID - Mismatch
8	PV Number - Mismatch
9	Number of PV Values - Mismatch
10	Cold Junction Ref - Mismatch
11	Open Thermocouple Detect - Mismatch
12	Freq 50 - Mismatch
13	Spare
14	Spare
15	Spare

Special DB byte

Bit	Description
0	Initial Power-up Data base
1	1st DB Capture in progress
2	4 Byte Data Base
3	No DE Data Available
4	SFC Write Detected
5	Output Mode
6	Not Used
7	Not Used

Status Bits 1

Bit	Description
0	
1	
2	
3	
4	
5	
6	
7	

Status Bits 2

Bit	Description
0	

1	
2	
3	
4	
5	
6	
7	

Status Bits 3

Bit	Description
0	
1	
2	
3	
4	
5	
6	
7	

PV Number

In a multi-variable transmitter, this value indicates the relative number of the PV value coming from the instrument . Used in combination with Number of PV value in low byte. In a single variable instrument, this will have a value of 1.

Number of PVs

Indicates the total number of PV values being returned from the instrument. This value will be 1 in a single variable instrument

PV Value - 0 to 4095

A 12-bit representation of the value being returned in the PV - Last Good Value field. This value is intended to be used for PID logic and other applications which would require that the Floating Point value be de-scaled. This value is initialized to 0 during power up.

Config database update counter

Updated by the DE CPU, for debug purposes, everytime the instrument data base has been completely received. The counter increments from 0 to 0ffh and then wraps around to 0.

Communication error counter

Updated by the DE CPU, for debug purposes, to indicate the number of DE communication errors which have occurred since reset. The counter increments from 0 to 0ffh and then wraps around to 0.

PV updated counter

Updated by the DE CPU everytime the PV value is received from an instrument. Note also that the COMM LED on the module will also toggle on when a PV is received.

SV updated counter

Updated by the DE CPU everytime the SV variable is received from an instrument

Function

This value describes the operating mode of the DEM for the DE Channel and the corresponding transmitter. The following modes are defined and/or supported:

Fctn	Description
0	Imaging PV (Default)
1	Download Transmitter Parameters to Instrument
2	Upload Transmitter Parameters Performed in ladder logic. Copies data base read back from instrument into write registers
3	Set LRL (Not supported, use mode #1)
4	Set URL (Not supported, use mode #1)
5	Correct LRL (Not supported, use mode #1)
6	Correct URL (Not supported, use mode #1)

- 7 Correct Zero Point (Not supported, use mode #1)
- 8 Restore Calib (Not supported)

DE CFG - Operational Mode

Indicates the DE operational mode for the transmitter configuration and the data which will be returned from the instrument. The available values are as follows:

- 0 Analog Mode
- 1 PV value only
- 2 PV and SV only
- 3 PV and Configuration Data Base (6 Byte mode)
- 4 PV, SV and Configuration Data Base (6 Byte Mode)

Note that the DE CFG value must be at least a 3 (instrument must be in 6 byte mode) in order for the database to be read from the instrument

Damping

This is the damping value correspond to the particular damping value in the transmitter. These values are based on a lookup table which is a function of the type of transmitter.

Damping	SPT	STT	SFM
0	0.0	0.0	0.0
1	0.16	0.30	0.5
2	0.32	0.70	1.0
3	0.48	1.5	2.0
4	1.0	3.1	3.0
5	2.0	6.3	4.0
6	4.0	12.7	5.0
7	8.0	25.5	10.0
8	16.0	51.1	50.0
9	32.0	102.3	100.0

PV Characterization

This parameter defines the algorithm used in the transmitter for process variable characterization. The correct PV Characterization parameter chosen when downloading the database must be in the set that is supported by the transmitter installed in the DE Channel.

The PV Characterization value is not checked by the DEM module against the transmitter type. The User must be cautious when writing the value to be sure that the correct value is selected

Sensor Type

Value indicates the type of instrument which is connected to the DE Channel. Possible values are:

Value	Hex	Description
8	8	SPT DP
9	9	SPT GP
10	A	SPT AP
11	B	STT
12	C	SFM
13	D	SCM
14	E	SGC
15	F	SVP
16	10	MTT
17	11	STP
18	12	SLV
19	13	SDU
20	14	Generic

Appendix D
Field Terminal Assembly Connections

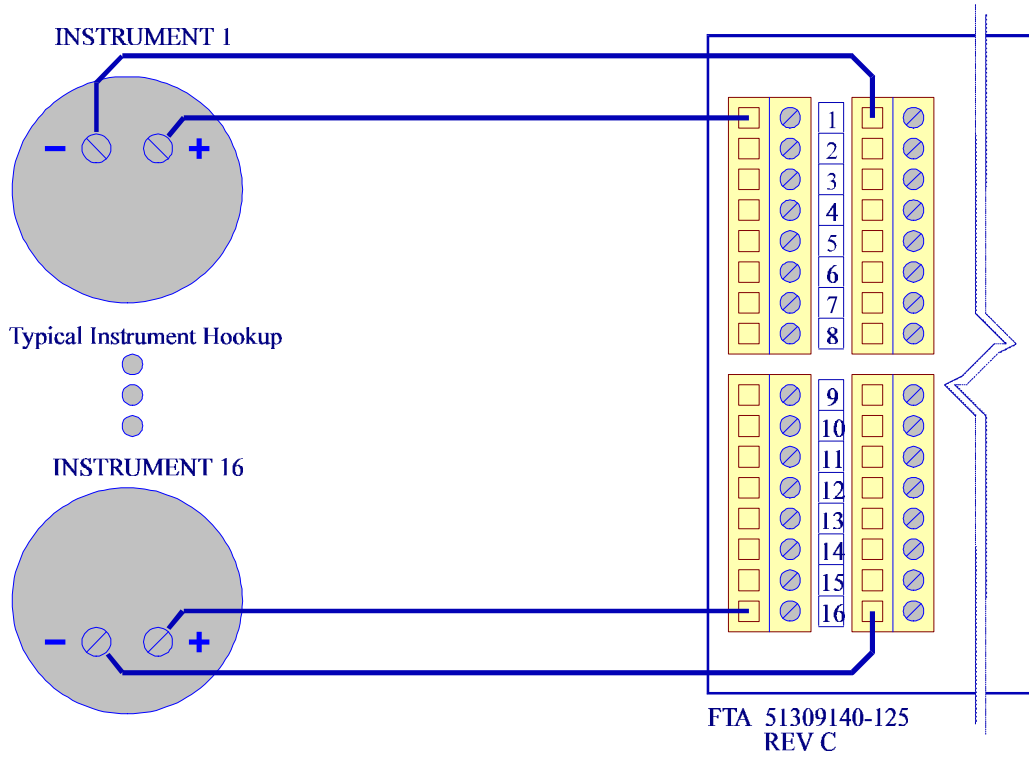

Installation Instructions:

Power, input and output wiring must be in accordance with Class I, Division 2 wiring methods [Article 501-4(b) of the National Electrical Code, NFPA 70] and in accordance with the authority having jurisdiction. The following warnings must also be heeded:

- A. Warning – Explosion Hazard – Substitution of components may impair suitability for Class I, Division 2
- B. Warning – Explosion Hazard – When in hazardous locations, turn off power before replacing or wiring modules
- C. Warning – Explosion Hazard – Do not disconnect equipment unless power has been switched off or the area is known to be nonhazardous.

Support, Service and Warranty

Technical Support

ProSoft Technology survives on its ability to provide meaningful support to its customers. Should any questions or problems arise, please feel free to contact us at:

Factory/Technical Support

ProSoft Technology, Inc.
9801 Camino Media, Suite 105
Bakersfield, CA 93311
(805) 664-7208
(800) 326-7066
(805) 664-7233 (fax)

E-mail address: prosoft@prosoft-technology.com

Before calling for support, please prepare yourself for the call. In order to provide the best and quickest support possible, we will most likely ask for the following information (you may wish to fax it to us prior to calling):

1. Product Version Number
2. Configuration Information
3. System hierarchy
4. Physical connection information
5. Module Operation
 - Block Transfers operation
 - LED patterns

An after-hours answering service (on the Bakersfield number) allows pager access to one of our qualified technical and/or application support engineers at any time to answer the questions that are important to you.

Module Service and Repair

The ProSoft product is an electronic product, designed and manufactured to function under somewhat adverse conditions. As with any product, through age, misapplication, or any one of many possible problems, the card may require repair.

When purchased from ProSoft Technology, the module has a one year parts and labor warranty according to the limits specified in the warranty. Replacement and/or returns should be directed to the distributor from whom the product was purchased. If you need to return the card for repair, it is first necessary to obtain an RMA number from ProSoft Technology. Please call the factory for this number and display the number prominently on the outside of the shipping carton used to return the card.

General Warranty Policy

ProSoft Technology, Inc. (Hereinafter referred to as ProSoft) warrants that the Product shall conform to and perform in accordance with published technical specifications and the accompanying written materials, and shall be free of defects in materials and workmanship, for the period of time herein indicated, such warranty period commencing upon receipt of the Product.

This warranty is limited to the repair and/or replacement, at ProSoft's election, of defective or non-conforming Product, and ProSoft shall not be responsible for the failure of the Product to perform specified functions, or any other non-conformance caused by or attributable to: (a) any misapplication or misuse of the Product; (b) failure of Customer to adhere to any of ProSoft's specifications or instructions; (c) neglect of, abuse of, or accident to, the Product; or (d) any associated or complementary equipment or software not furnished by ProSoft.

Limited warranty service may be obtained by delivering the Product to ProSoft and providing proof of purchase or receipt date. Customer agrees to insure the Product or assume the risk of loss or damage in transit, to prepay shipping charges to ProSoft, and

to use the original shipping container or equivalent. Contact ProSoft Customer Service at (805) 664-7208 for further information.

Limitation of Liability

EXCEPT AS EXPRESSLY PROVIDED HEREIN, PROSOFT MAKES NO WARRANTY OF ANY KIND, EXPRESSED OR IMPLIED, WITH RESPECT TO ANY EQUIPMENT, PARTS OR SERVICES PROVIDED PURSUANT TO THIS AGREEMENT, INCLUDING BUT NOT LIMITED TO THE IMPLIED WARRANTIES OF MERCHANTABILITY AND FITNESS FOR A PARTICULAR PURPOSE. NEITHER PROSOFT OR ITS DEALER SHALL BE LIABLE FOR ANY OTHER DAMAGES, INCLUDING BUT NOT LIMITED TO DIRECT, INDIRECT, INCIDENTAL, SPECIAL OR CONSEQUENTIAL DAMAGES, WHETHER IN AN ACTION IN CONTRACT OR TORT (INCLUDING NEGLIGENCE AND STRICT LIABILITY), SUCH AS, BUT NOT LIMITED TO, LOSS OF ANTICIPATED PROFITS OR BENEFITS RESULTING FROM, OR ARISING OUT OF, OR IN CONNECTION WITH THE USE OR FURNISHING OF EQUIPMENT, PARTS OR SERVICES HEREUNDER OR THE PERFORMANCE, USE OR INABILITY TO USE THE SAME, EVEN IF PROSOFT OR ITS DEALER'S TOTAL LIABILITY EXCEED THE PRICE PAID FOR THE PRODUCT.

Where directed by State Law, some of the above exclusions or limitations may not be applicable in some states. This warranty provides specific legal rights; other rights that vary from state to state may also exist. This warranty shall not be applicable to the extent that any provisions of this warranty is prohibited by any Federal, State or Municipal Law that cannot be preempted.

Hardware Product Warranty Details

Warranty Period : ProSoft warranties hardware product for a period of one (1) year.

Warranty Procedure : Upon return of the hardware Product ProSoft will, at its option, repair or replace Product at no additional charge, freight prepaid, except as set forth below. Repair parts and replacement Product will be furnished on an exchange basis and will be either reconditioned or new. All replaced Product and parts become the property of ProSoft. If ProSoft determines that the Product is not under warranty, it will, at the Customer's option, repair the Product using current ProSoft standard rates for parts and labor, and return the Product freight collect.

Example PLC 5 Ladder Logic

Overview

The following ladder logic provides an example for the ladder logic necessary to integrate the 3700-DEM module into a SCAN 3000 Application. This logic can be incorporated directly as is, or if desired modified as needed for the application.

The ladder logic is build around the presumption that the memory map for the data will follow that needed to interface directly with the SCAN 3000 software. As such, the register mapping detailed in Appendix A is followed.

Specifically, in the example logic, the following files have been used:

Integer	N30
Float	F31
ASCII	A32

Also in this example ladder logic, the following registers are used:

B3:0	Working bit image
B3/0	documentation bit
B3/1	documentation bit
N9:0 to N9:9	Working pointers
BT27:0,:1	Block Transfer Control
N7:300 -464	Block Transfer Data registers