

HC900 Control Station

Model Numbers 900CS10-00 and 900CS15-00

Installation

Document Number: 51-52-33-157 Revision 4

Effective: 05/17/10

Supersedes: Revision 3

Summary

These instructions explain how to install your Control Station. Once installed, the unit must be configured. Configuration is a detailed process described in other documents.

The overall steps for getting your Control Station up and running are as follows.

Step	Action
1	Install the unit per this instruction sheet.
	<i>Refer to other documentation for details on the following steps.</i>
2	After completing installation, configure the HC900 controller for your application using Hybrid Control Designer software and save the .cde file.
3	Using Station Designer software, create data tags from your .cde file, create your operator interface configuration and save the .sds file.
4	Download the .sds file to the 900 Control Station and verify operation.

Note: Configuration of the 900 Control Station may be performed prior to mounting if found to be more convenient when using the USB port since once loaded the configuration is maintained in non-volatile memory, but doing so requires the station to be connected to a 24Vdc power supply.

Contents of package

Check that you received the following items.

- Control Station
- Panel Gasket
- Template for panel cutout
- Hardware packet for mounting unit into panel
- Power connector (3 terminals)
- Documentation CD

Supplied separately

- Flash Memory Module (optional) Note: The Flash Memory Module must be a UL approved component Smart Modular Technologies model SG9CF (UL Listed Directory Category NWGQ) to maintain UL station approval when installed.

Safety Summary



SUITABLE FOR USE IN CLASS I, DIVISION 2 GROUPS A, B, C AND D HAZARDOUS LOCATIONS, OR NONHAZARDOUS LOCATIONS ONLY

43NH

PROCESS CONTROL EQUIPMENT



WARNING - EXPLOSION HAZARD

DO NOT DISCONNECT EQUIPMENT WHILE THE CIRCUIT IS LIVE OR UNLESS THE AREA IS KNOWN TO BE FREE OF IGNITABLE CONCENTRATIONS



WARNING - EXPLOSION HAZARD

SUBSTITUTION OF ANY COMPONENT MAY IMPAIR SUITABILITY FOR CLASS I, DIVISION 2



WARNING - EXPLOSION HAZARD

BATTERIES MUST ONLY BE CHANGED IN AN AREA KNOWN TO BE NON-HAZARDOUS.

BATTERIES MUST BE UL RECOGNIZED (UL RECOGNIZED COMPONENT DIRECTORY CATEGORY BBCV2) LITHIUM BATTERIES TYPE CR2025 MANUFACTURED BY SANYO ENERGY CORP. OR VARTA BATTERIE AG OR PANASONIC.



WARNING - EXPLOSION HAZARD

DO NOT CONNECT OR DISCONNECT CABLES WHILE POWER IS APPLIED UNLESS AREA IS KNOWN TO BE NON-HAZARDOUS. USB PORT IS FOR SYSTEM SET-UP AND DIAGNOSTICS AND IS NOT INTENDED FOR PERMANENT CONNECTION



WARNING - EXPLOSION HAZARD

THE AREA MUST BE KNOWN TO BE NON-HAZARDOUS BEFORE SERVICING / REPLACING THE UNIT AND BEFORE INSTALLING OR REMOVING I/O WIRING.

ATTENTION

Failure to follow these installation instructions could result in diminished performance and/or invalidate the UL approvals.

Installation procedure overview

Refer to the pages shown for details on each step.

<u>Step</u>	<u>See page</u>
1. INSTALL FLASH MEMORY MODULE (IF PURCHASED SEPARATELY)	3
2. MOUNT THE CONTROL STATION	4
3. CONNECT TO EARTH GROUND	6
4. MOUNT AND CONNECT POWER SUPPLY	6
5. CONNECT COMMUNICATIONS	7

1. Install Flash Memory Module (if purchased separately)

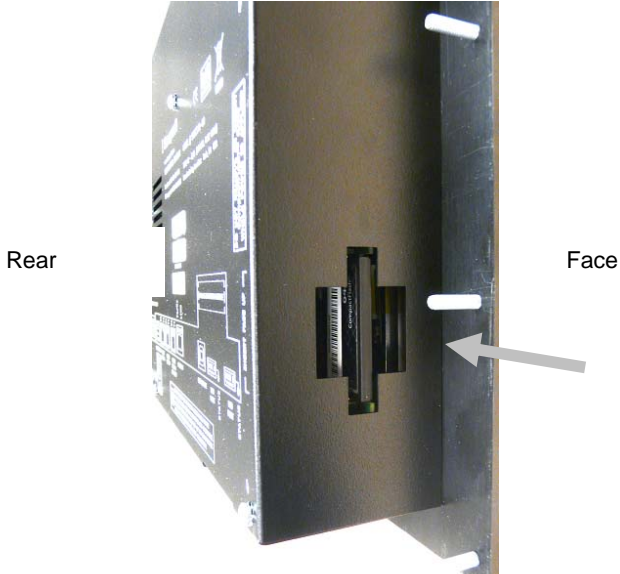
Step A	ction
1	<p>With the 900 Control Station positioned face forward, and with connectors on the bottom, locate the Flash Memory Module receptacle through the access hole on the right side of the case.</p> 
2	<p>Insert the Flash Memory Module into the connector, being sure the card is fully engaged in its receptacle. Note the card is keyed to assure proper orientation.</p>
Note	<p>Control Station supports a minimum of 4MB and a maximum of 2GB Compact Flash memory card.</p>
Note	<p>The Flash Memory Module should not be installed or removed while the Control Station has power applied.</p>

2. Mount the Control Station

Model 900CS10-00

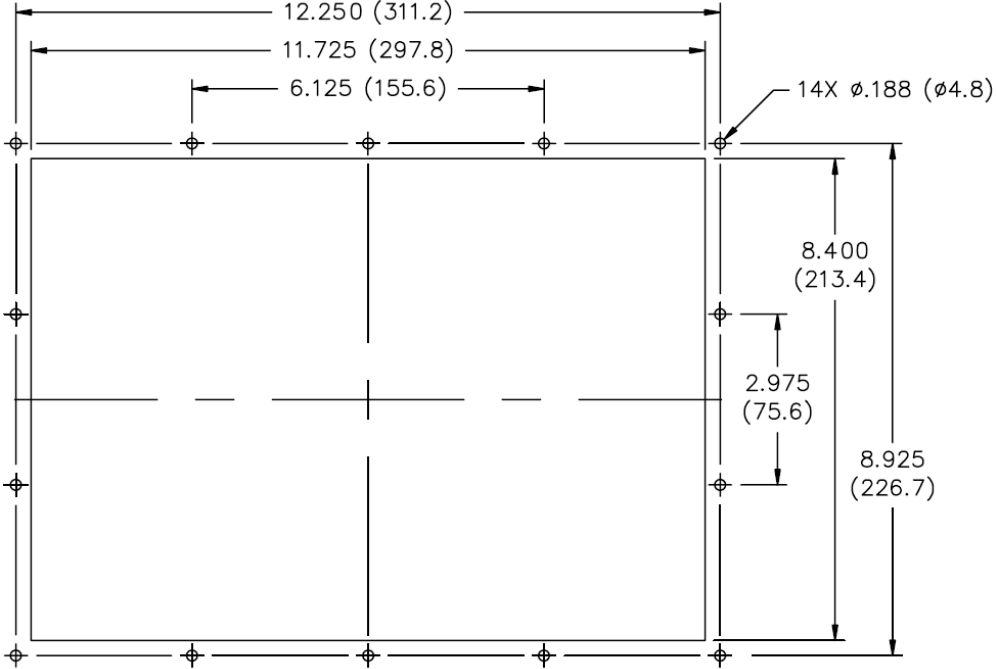
Step A	ction
	<p>ATTENTION</p> <p>If the 900 Control Station is replacing an existing product, contact your local Honeywell representative for instructions.</p>
<p>1</p>	<p>Using the drawing below, cut panel hole. You can use the cardboard template as a rough guide but be sure to measure against the drawing below before cutting. Drill holes using a 3/16 inch (4.76mm) size drill bit. Remove any loose material from the mounting cut-out to prevent that material from falling into the Control Station during installation.</p>  <p style="text-align: center;"><i>All tolerances ±0.010" (±0.25 mm).</i></p>
<p>2</p>	<p>Mount the gasket by placing its 14 holes over the Control Station's 14 mounting bolts. Push gasket all the way on to the mounting bolts. Insert Control Station into panel cutout.</p>
<p>3</p>	<p>Install the 14 keps provided with the Control Station. Tighten evenly for uniform gasket compression. Do not tighten the keps beyond a maximum of 17 inch-pounds (1.92 N-m) or you may cause damage to the Control Station's front panel.</p>

Model 900CS15-00

Step A	ction
<p>1</p>	<p>Using the drawing below, cut panel hole. You can use the cardboard template as a rough guide but be sure to measure against the drawing below before cutting. Drill holes using a 3/16 inch (4.76mm) size drill bit. Remove any loose material from the mounting cut-out to prevent that material from falling into the Control Station during installation.</p> <p style="text-align: center;"><i>All tolerances ±0.010" (±0.25 mm).</i></p>
<p>2</p>	<p>Mount the gasket by placing its 22 holes over the Control Station's 22 mounting bolts. Push gasket all the way on to the mounting bolts. Insert Control Station into panel cutout.</p>
<p>3</p>	<p>Install the 22 keps provided with the Control Station. Tighten evenly for uniform gasket compression. Do not tighten the keps beyond a maximum of 17 inch-pounds (1.92 N-m) or you may cause damage to the Control Station's front panel.</p>

General wiring considerations

- Use only Class I, Division 2 wiring methods as specified in the National Electrical Code NFPA70 and the Canadian Electrical Code C22.1.
- The Control Station cables contain low voltages. Keep cables away from high voltage wires that can cause interference.
- CE testing was performed with shielded, twisted pair cables. For noise reduction tips, see Honeywell document 51-52-05-01, How to Apply Digital Instrumentation in Severe Electrical Noise Environments.



ATTENTION

The emission limits of EN 55011 (CISPR11) are designed to provide reasonable protection against harmful interference when this equipment is operated in an industrial environment. Operation of this equipment in a residential area may cause harmful interference. This equipment generates, uses, and can radiate radio frequency energy and may cause interference to radio and television reception when the equipment is used closer than 30 meters to the antenna (e). In special cases, when highly susceptible apparatus is used in close proximity, the user may have to employ additional mitigating measures to further reduce the electromagnetic emissions of this equipment.

3. Connect to earth ground

The back of the unit has a chassis ground terminal identified with the symbol . Connect this terminal to earth ground (protective earth).

The chassis ground is not connected to signal common of the unit electronics. Maintaining isolation between earth ground and signal common is not required to operate the unit, but when connecting the HC900 controller to the unit using the recommended shielded CAT5 Ethernet cable, a path to earth ground is created via the Ethernet shield of the controller. Other equipment connected to the unit may require isolation between signal common and earth ground. To maintain isolation, care must be taken when connections are made to the unit. For example, a power supply with isolation between its signal common and earth ground must be used.

Connecting a device via a USB cable may also connect signal common and earth ground. The shield of the USB's connector at the host may be connected to earth ground. A USB's shield may also be connected to signal common.

4. Mount and connect power supply

The Control Station requires a 24 VDC power supply rated at 29 W or more. Your unit may draw considerably less than rated power depending upon the options being used. As additional features are used your unit will draw increasing amounts of power. Items that could cause increases in current are additional communications, Flash Memory Module, and other features programmed using Station Designer software.

It is important that the power supply is mounted and wired correctly if the unit is to operate reliably. Please take care to observe the following points.

- A 10" model requires a minimum of 29 Watts of power supply and a 15" model requires a minimum of 46 Watts of power supply.
- The power supply should be mounted close to the unit. Recommended not more than 6 feet (1.8 m) of cable between the supply and the Control Station. Ideally, the shortest length possible should be used.
- A power supply with isolation between its signal common and earth ground must be used.
- The wire used to connect the power supply to the Control Station should be at least 22-gage wire. If a longer cable run is used, a heavier gage wire should be used.
- The routing of the cable should be kept away from large contactors, inverters, and other devices which may generate significant electrical noise.

- A power supply with a Class 2 or SELV rating should be used. A Class 2 or SELV power supply provides isolation to accessible circuits from hazardous voltage levels generated by a mains power supply due to single faults. SELV is an acronym for “safety extra-low voltage.” Safety extra-low voltage circuits shall exhibit voltages safe to touch both under normal operating conditions and after a single fault, such as a breakdown of a layer of basic insulation or after the failure of a single component has occurred.
- If the power supply will be mounted in a hazardous location, it must be rated for Class I, Div. 2 by an OSHA recognized NRTL, such as UL or FM.
- Using the terminal block provided, connect the power supply’s +24Vdc lead to terminal 2 and the Common lead to terminal 1. See figure below. Plug the terminal block into the connector located on the bottom of the interface.

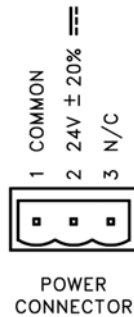

5. Connect communications

Overview

Connections and ports used depend on the architecture of your installation.

See architecture examples starting on page 7.

For cabling and connections, see page 11.

For details on connections to devices other than the Control Station, see *HC900 Hybrid Controller Installation and User Guide*, document number 51-52-25-107.

When your connections are finished, installation is complete and your unit is ready to be configured. Refer to the appropriate manuals for details.

Example #1

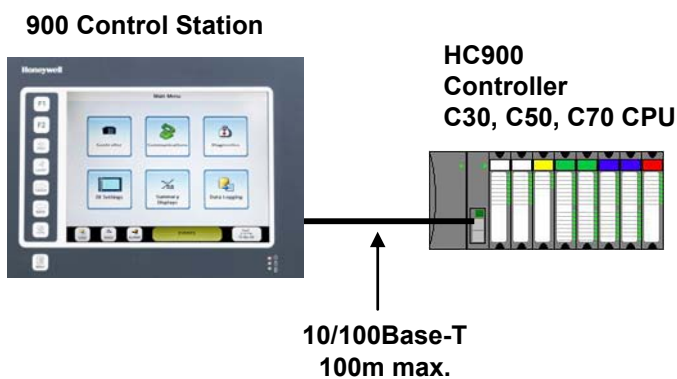

Use shielded CAT5 cable with RJ45 connectors. Connect to HC900 Ethernet port. (On models C70 and C70R with two ports E1 and E2; either port can be used.)

Example #2

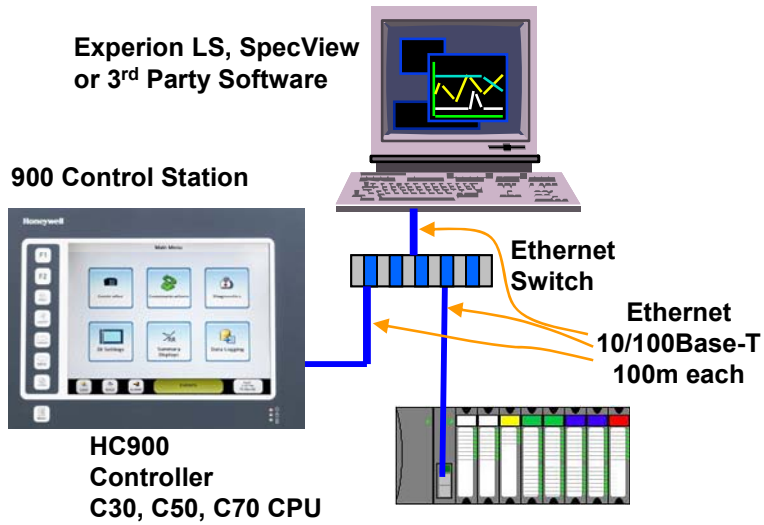

Use shielded CAT5 cable with RJ45 connectors. Connect to HC900 Ethernet port. (On models C70 and C70R with two ports E1 and E2; either port can be used.)

Example #3

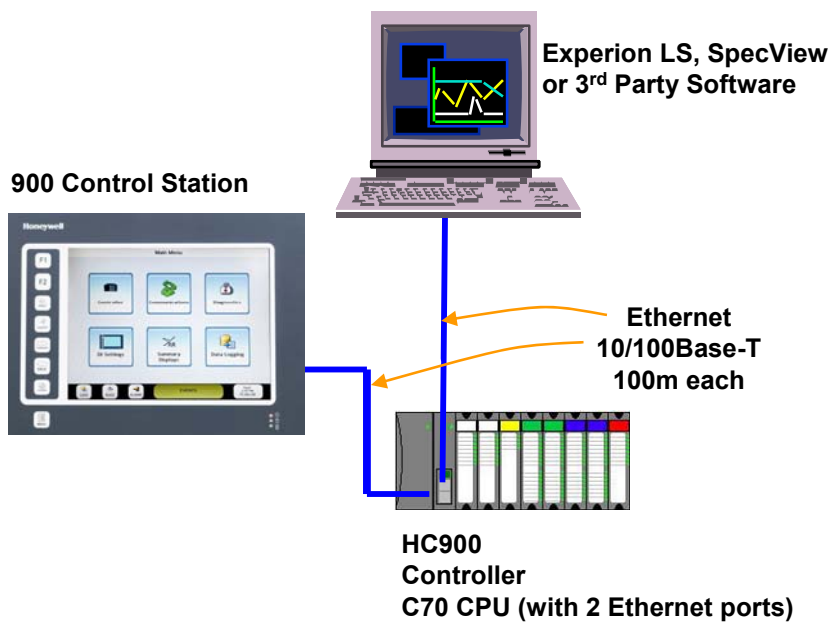

Use shielded CAT5 cable with RJ45 connectors. Connect to HC 900 to E2 of the C70 CPU and connect the host PC to E1.

Example #4

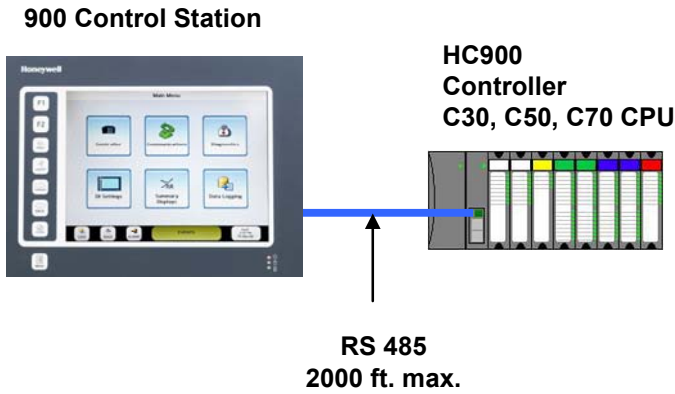

Connect to HC900 RS485 port with unterminated switch settings. S2 port is RS485 terminated by default; S1 port can be configured as RS485.

RS-232 RS-485	unterminated	RS-485 terminated (last link in network)	RS-485 with external bias, unterminated

See manual 51-52-25-107 for full details.

Note: Ethernet connections will provide faster performance than RS-485.

Example #5

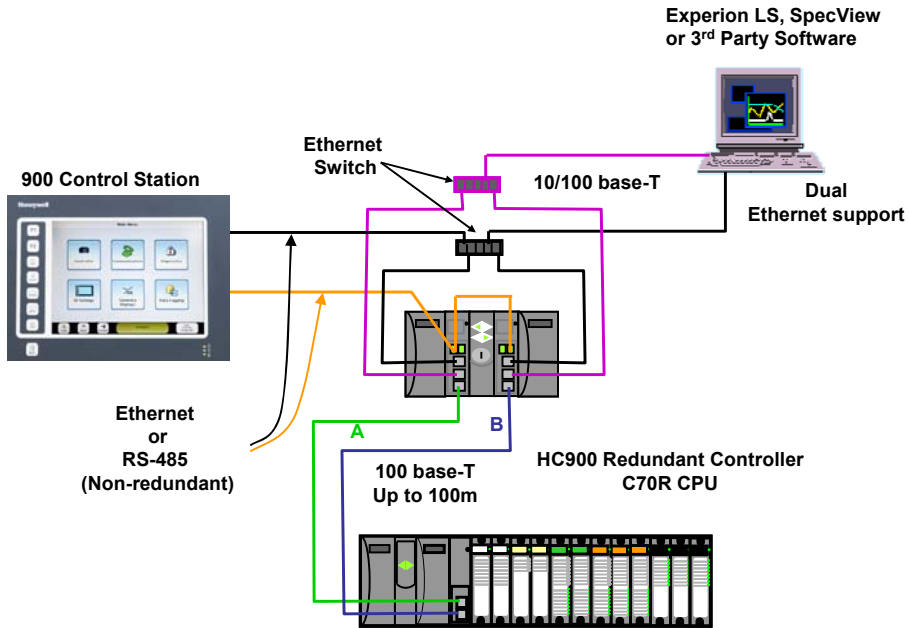

Connect to C70R using either RS-485 or Ethernet. Communication redundancy is not supported using both RS 485 and Ethernet. Communications to the Lead CPU is maintained following a CPU failover event.

Example #6

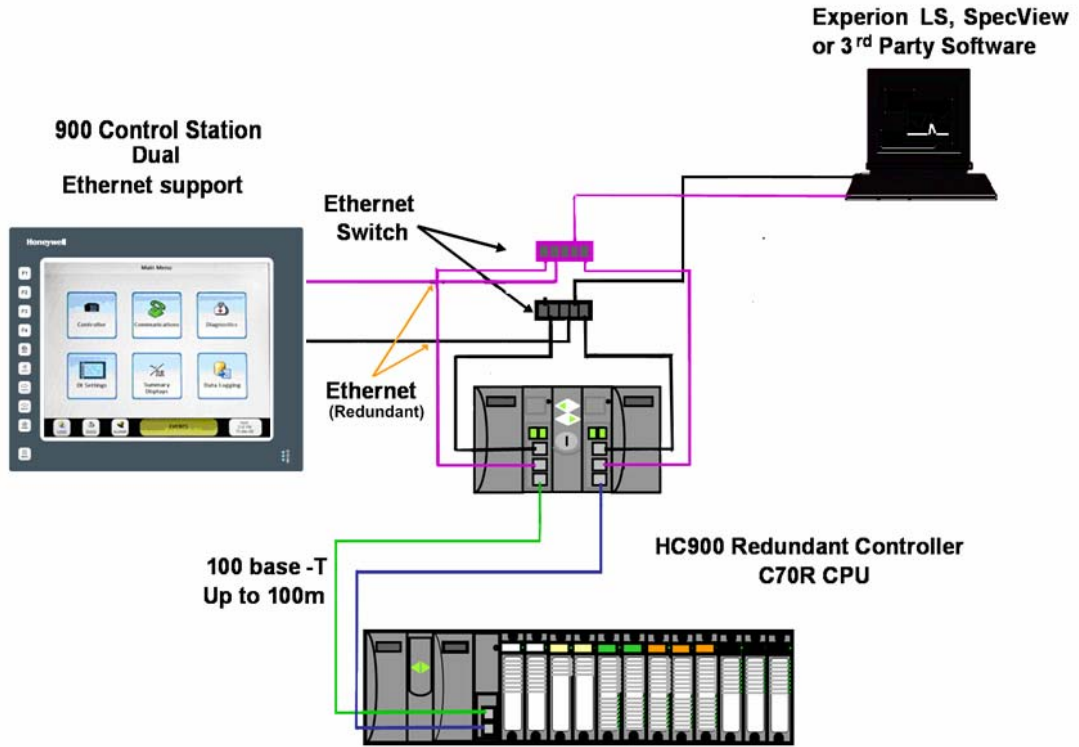

Connect to C70R using dual Ethernet cables.

Example #7

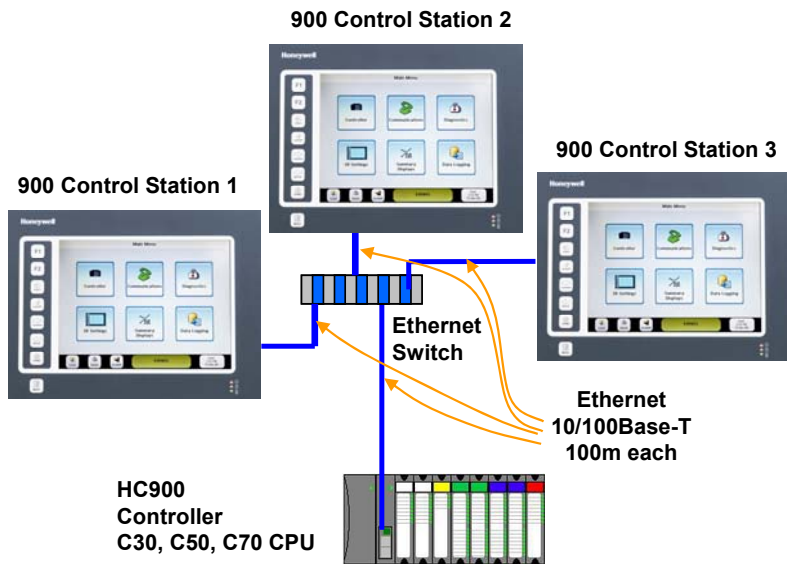

Up to 3 Control Stations may be connected to a HC900 controller using Ethernet. Multiple stations via RS 485 are not supported.

Cables

Ethernet



Ethernet communications are recommended for best performance.

Use shielded CAT5 cable (Honeywell part no. 514514032). Cable length must be less than 100 meters. For longer distances use Ethernet switches between cables. The use of Ethernet cables in excess of 100 meters may cause transmission delays that could have adverse affects on performance.

RS485

For RS485 between Control Station and HC900, construct a cable as follows.

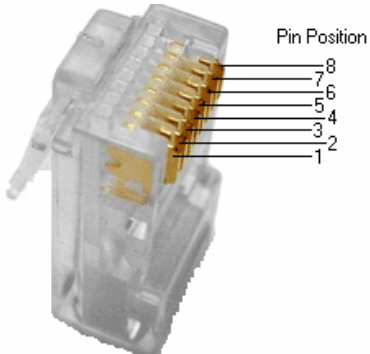
1. Cut off one connector of the shielded CAT5 cable.
2. Connect the wires indicated to the 3-plug connector that was supplied with the HC900 CPU module. See table below.

Shielded CAT5 cable		3-plug connector	
			
Signal	Pin		Terminal
Shield (aluminum-polyester foil tape with 26 AWG stranded drain wire)		Connect to	1
TXA	2	Connect to	2
TXB	1	Connect to	3
RXA	3		
RXB	4		
TXEN	5		
Common	6		
TXB	7	Connect to	3
TXA	8	Connect to	2

3. Cut off any unused wires in the cable and insulate with heat shrink tubing or other appropriate insulating material.

This connector plugs into the HC900's RS485 port; the RJ45 connector plugs into the Control Station's RS485 port.

RS232 Communications

If using RS232 communications to have the station communicate with other Honeywell or Modbus-compatible equipment, create a communications cable as follows.

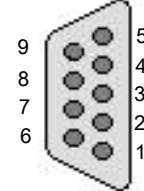
RJ12 connector		Connector of slave device	
			
Terminal no.	Signal	Terminal no.	Signal
1	CTS	7	RTS
2	RX	3	TXD
3	Ground	5	Ground
4	Ground	1	DCD
5	TX	2	RXD
6	RTS	8	CTS

Specifications – apply to all models unless specified.

<p>Environmental</p>	<p>Operating Temperature Range: 0 to 50 °C (32 to 122 F)</p> <p>Storage Temperature Range: -20 to 70 °C (-4 to 158 °F)</p> <p>Operating and Storage Humidity: 80% maximum relative humidity (non-condensing) from 0 to 50°C.</p> <p>Vibration According to IEC 68-2-6: 5 to 150 Hz, in X, Y, Z direction for 1.5 hours, 2 g.</p> <p>Shock According to IEC 68-2-27: Operational 35 g, 9 msec in 3 directions.</p> <p>Type 4X Indoor use only Enclosure rating (face only), UL50.</p> <p>IP66 Enclosure rating (face only), IEC529.</p> <p>Altitude: Up to 2000 meters.</p>																					
<p>Safety</p>	<p>EN 61010-1 – 2001. CE Mark requirements for General Purpose (Ordinary Location) Safety.</p> <p>ANSI/UL 61010-1 – 2005, Second Edition. General Purpose (Ordinary Location) Safety.</p> <p>UL evaluated to CSA C22.2 No. 61010-1-2004- Second Edition. General Purpose (Ordinary Location) Safety.</p> <p>Class I, Div 2 Groups A,B,C,D - Hazardous (Classified) Location Safety for USA and Canada</p>																					
<p>Electromagnetic Compatibility</p>	<p>IEC61326 - 2005 CE Mark EMC requirements for electrical equipment for measurement, control and laboratory use.</p> <p>Immunity to Industrial Locations:</p> <table border="0"> <tr> <td data-bbox="488 991 727 1081">ESD</td> <td data-bbox="727 991 935 1017">IEC 61000-4-2</td> <td data-bbox="935 991 1433 1081"> Criterion A 4kV contact discharge 8kV air discharge </td> </tr> <tr> <td data-bbox="488 1091 727 1215">EM field</td> <td data-bbox="727 1091 935 1117">IEC 61000-4-3</td> <td data-bbox="935 1091 1433 1215"> Criterion A 10 V/m (80 MHz to 1 GHz) 3 V/m (1.4 GHz to 2 GHz) 1 V/m (2.0 GHz to 2.7 GHz) </td> </tr> <tr> <td data-bbox="488 1225 727 1349">Electrical Fast Transient/Burst</td> <td data-bbox="727 1225 935 1251">IEC 61000-4-4</td> <td data-bbox="935 1225 1433 1349"> Criterion A 2kV power 1kV I/O signal/control, including functional earth lines </td> </tr> <tr> <td data-bbox="488 1359 727 1483">Surge</td> <td data-bbox="727 1359 935 1385">IEC 61000-4-5</td> <td data-bbox="935 1359 1433 1483"> Criterion B 1kV L-L, 2kV L-Gnd power 1kV I/O signal/control, including functional earth lines </td> </tr> <tr> <td data-bbox="488 1493 727 1555">Conducted RF</td> <td data-bbox="727 1493 935 1519">IEC 61000-4-6</td> <td data-bbox="935 1493 1433 1555"> Criterion A 3Vrms Power and all I/O </td> </tr> <tr> <td data-bbox="488 1566 727 1627">Magnetic field</td> <td data-bbox="727 1566 935 1591">IEC 61000-4-8</td> <td data-bbox="935 1566 1433 1627"> Criterion A 30A/m </td> </tr> </table> <p>Emissions:</p> <table border="0"> <tr> <td data-bbox="488 1740 727 1800">Emissions</td> <td data-bbox="727 1740 935 1800">EN 55011 (CISPR11)</td> <td data-bbox="935 1740 1433 1800">Class A</td> </tr> </table>	ESD	IEC 61000-4-2	Criterion A 4kV contact discharge 8kV air discharge	EM field	IEC 61000-4-3	Criterion A 10 V/m (80 MHz to 1 GHz) 3 V/m (1.4 GHz to 2 GHz) 1 V/m (2.0 GHz to 2.7 GHz)	Electrical Fast Transient/Burst	IEC 61000-4-4	Criterion A 2kV power 1kV I/O signal/control, including functional earth lines	Surge	IEC 61000-4-5	Criterion B 1kV L-L, 2kV L-Gnd power 1kV I/O signal/control, including functional earth lines	Conducted RF	IEC 61000-4-6	Criterion A 3Vrms Power and all I/O	Magnetic field	IEC 61000-4-8	Criterion A 30A/m	Emissions	EN 55011 (CISPR11)	Class A
ESD	IEC 61000-4-2	Criterion A 4kV contact discharge 8kV air discharge																				
EM field	IEC 61000-4-3	Criterion A 10 V/m (80 MHz to 1 GHz) 3 V/m (1.4 GHz to 2 GHz) 1 V/m (2.0 GHz to 2.7 GHz)																				
Electrical Fast Transient/Burst	IEC 61000-4-4	Criterion A 2kV power 1kV I/O signal/control, including functional earth lines																				
Surge	IEC 61000-4-5	Criterion B 1kV L-L, 2kV L-Gnd power 1kV I/O signal/control, including functional earth lines																				
Conducted RF	IEC 61000-4-6	Criterion A 3Vrms Power and all I/O																				
Magnetic field	IEC 61000-4-8	Criterion A 30A/m																				
Emissions	EN 55011 (CISPR11)	Class A																				

Warranty/Remedy

Honeywell warrants goods of its manufacture as being free of defective materials and faulty workmanship. Contact your local sales office for warranty information. If warranted goods are returned to Honeywell during the period of coverage, Honeywell will repair or replace without charge those items it finds defective. The foregoing is Buyer's sole remedy and is **in lieu of all other warranties, expressed or implied, including those of merchantability and fitness for a particular purpose.** Specifications may change without notice. The information we supply is believed to be accurate and reliable as of this printing. However, we assume no responsibility for its use.

While we provide application assistance personally, through our literature and the Honeywell web site, it is up to the customer to determine the suitability of the product in the application

Honeywell