

Quick Start Manual • April 2009



English
Dansk
Deutsch
Ελληνικά
Español
Français
Italiano
Nederlands
Português
Suomi
Svenska

million
in one

sitrans

LG200

SIEMENS

SITRANS LG200 Quick Start Manual

This manual outlines the essential features and functions of the SITRANS LG200. We strongly advise you to acquire the detailed version of the manual so you can use your instrument to its complete potential. The complete manual is available on the SITRANS LG200 product page of our website at: <https://pia.khe.siemens.com/index.asp?Nr=15361>. Questions about the content of this manual can be directed to:

Siemens Milltronics Process Instruments Inc.
1954 Technology Drive, P.O. Box 4225
Peterborough, Ontario, Canada, K9J 7B1
Email: techpubs.smpi@siemens.com

**Copyright Siemens Milltronics
Process Instruments Inc. 2008.
All Rights Reserved**

Disclaimer of Liability

We encourage users to purchase authorized bound manuals, or to view electronic versions as designed and authored by Siemens Milltronics Process Instruments Inc. Siemens Milltronics Process Instruments Inc. will not be responsible for the contents of partial or whole reproductions of either bound or electronic versions.

While we have verified the contents of this manual for agreement with the instrumentation described, variations remain possible. Thus we cannot guarantee full agreement. The contents of this manual are regularly reviewed and corrections are included in subsequent editions. We welcome all suggestions for improvement.

Technical data subject to change.

MILLTRONICS is a registered trademark of Siemens Milltronics Process Instruments Inc.

Safety Guidelines

Warning notices must be observed to ensure personal safety as well as that of others, and to protect the product and the connected equipment. These warning notices are accompanied by a clarification of the level of caution to be observed.



WARNING: relates to a caution symbol on the product, and means that failure to observe the necessary precautions can result in death, serious injury, and/or considerable material damage.



WARNING¹: means that failure to observe the necessary precautions can result in death, serious injury, and/or considerable material damage.

Note: means important information about the product or that part of the operating manual.

¹ This symbol is used when there is no corresponding caution symbol on the product.

SITRANS LG200

- ! WARNING: Changes or modifications not expressly approved by Siemens could void the user's authority to operate the equipment.**

Notes:

- This equipment has been tested and found to comply with the limits for a Class A digital device, pursuant to Part 15 of the FCC Rules. These limits are designed to provide reasonable protection against harmful interference when the equipment is operated in a commercial environment.
- This equipment generates, uses, and can radiate radio frequency energy and, if not installed and used in accordance with the instruction manual, may cause harmful interference to radio communications. Operation of this equipment in a residential area is likely to cause harmful interference, in which case the user will be required to correct the interference at his own expense.
- SITRANS LG200 is to be used only in the manner outlined in this manual, otherwise protection provided by the equipment may be impaired.]
- This product is intended for use in industrial areas. Operation of this equipment in a residential area may cause interference to several frequency based communications.

SITRANS LG200 is a guided wave radar transmitter for short and medium range level, level/interface and volume measurement of liquids and solids. It is unaffected by changes in process conditions, high temperatures and pressures, and steam.

SITRANS LG200 supports HART¹ communication protocol, and SIMATIC PDM software.

Specifications

For a complete listing, see the SITRANS LG200 Instruction Manual.

Ambient/Operating Temperature

- Ambient temperature: -40 to +80 °C (-40 to +175 °F)
- Max. process temperature and pressure: Probe type and pressure dependent; see process device tag for details

Power



General Purpose:
Intrinsically Safe:
Explosion Proof:

11 to 36 V DC

¹. HART® is a registered trademark of the HART Communication Foundation.

Approvals

Note: The device nameplate lists the approvals that apply to your device.

- General Purpose CSA/FM, CE, C-TICK
- Intrinsically Safe FM Class I, Div. 1, Groups A, B, C, D, Class II, Div. 1, Groups E, F, G T4, Class III, Type 4, IP65
- CSA Class I, Div. 1, Groups A, B, C, D, Class II, Div. 1, Groups E, F, G T4, Class III, Type 4, IP65
- ATEX II 1G EEx ia IIC T4
- Explosion Proof/ Flame Proof FM Class I, Div 1, Groups B, C, D, Class II, Div. 1, Groups E, F, G T4, Class III, Type 4, IP65
- CSA Class I, Div. 1, Groups B, C, D, Class II, Div. 1, Groups E, F, G T4, Class III, Type 4, IP65
- ATEX II 1/2 G EEx d [ja] IIC T6
- ATEX II 1/2 D IP65 T85 °C
- Non-Incendive FM Class I, Div. 2, Groups A, B, C, D, Class II, Div. 2, Groups F, G T4, Class III, Type 4, IP65
- CSA Class I, Div. 2, Groups A, B, C, D, Class II, Div. 2, Groups E, F, G T4, Class III, Type 4, IP65
- Non-sparking ATEX II 3G EEx nA [nL] IIC T4 to T6
- ATEX II 3G EEx nA II T4 to T6
- Others Functional Safety to SIL 1 in accordance with IEC 61508 Safe Failure Fraction (SFF) of 85.5% (Third party FMEDA Analysis - hardware only)
- Functional Safety to SIL 2 in accordance with IEC 61508 Safe Failure Fraction (SFF) of 91% (Third party FMEDA Analysis - hardware only)

Pressure Application



! WARNINGS:

- Do not attempt to loosen, remove, or disassemble process connection or instrument housing while vessel contents are under pressure.
- Improper installation may result in loss of process pressure.

Installation



- **WARNINGS:**
- This product can only function properly and safely if it is correctly transported, stored, installed, set up, operated, and maintained.
- Materials of construction are chosen based on their chemical compatibility (or inertness) for general purposes. For exposure to specific environments, check with chemical compatibility charts before installing.
- The user is responsible for the selection of bolting and gasket materials which will fall within the limits of the flange and its intended use, and which are suitable for the service conditions.

Mounting location

Note: For complete mounting instructions for all probe versions, please see the SITRANS LG200 instruction manual.

Recommendations

- Easy access for programming via device push buttons.
- An environment suitable to the enclosure rating and materials of construction.

Precautions

- Do not place insulating material around any part of SITRANS LG200 transmitter including the probe flange as this may cause excessive heat buildup.
- Avoid proximity to high voltage or current wiring, high voltage or current contacts, and to variable frequency motor speed controllers.
- Avoid interference to the emission cone from obstructions or from the fill path.
- Single Rod:
 1. Do not mount in nozzles <math>< 50\text{ mm (2")}</math> in diameter.
 2. Mount in applications where ratio of diameter:length is 1:1 or greater. Any ratio less than 1:1 (for example, a 2"x6" nozzle = 1:3) may require a blocking distance and/or dielectric adjustment.
 3. Do not use pipe reducers.
 4. Keep conductive objects away from probe to ensure proper performance.
- Twin rod:
 1. Active rod must be mounted at least 25 mm (1") away from any obstructions.
 2. Minimum stillwell or nozzle diameter for probe is 76 mm (3").

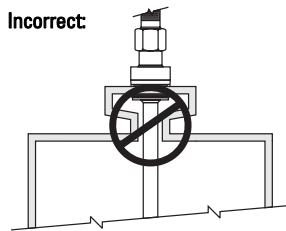
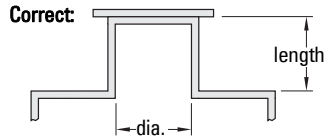

General probe mounting

1. Ensure the process connection is at least ¾" NPT for coaxial probes or 2" NPT for rigid probes or is a flanged mounting.
2. Carefully place the probe into the vessel. Align the gasket on flanged installations.
3. Align the probe process connection with the threaded or flanged mounting on the vessel.
4. For threaded connections, tighten the hex nut of the probe process connection. For flanged connections, tighten flange bolts.

Installation in non-metallic silos

For installation in vessels of a non-metallic construction or possibly open vessels, a suitable launch plate is required to optimize the impedance of the transmitted signal as it travels along the probe. Optimal performance cannot be guaranteed if a suitable transition is not available at the process connection.

When using single rod versions (flexible or solid) and a threaded process connection, a metal sheet or flange will greatly improve conditions as this provides a suitable launch plate.

A flanged process connection is generally accepted to be provision of this launch plate.

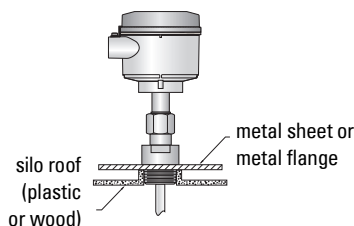

Note: The SITRANS LG200 meets CE requirements for Electromagnetic Compatibility (EN 61326-1/2006). Single and Twin Rod probes must be used in metallic vessel or stilling well to maintain CE compliance.

Transmitter (enclosure) installation

1. Remove the protective plastic cap from the top of the probe. Put the cap in a safe place in case the transmitter has to be removed later.
2. Place the transmitter on the probe. Be careful not to bend or dirty the gold, high frequency (male) connector.
3. Align the universal connection at the base of the transmitter housing with the top of the probe. Hand tighten the connection.
4. Rotate the transmitter to face the most convenient direction for wiring, configuration, and viewing.
5. When the transmitter is facing the desired direction, use a 38 mm (1½") wrench to tighten the universal connection on the transmitter to 15 ft.-lbs. A torque wrench is highly recommended. This is a critical connection. **DO NOT LEAVE HAND TIGHT.**

Wiring

Power

WARNINGS:



All HART versions of SITRANS LG200 transmitter operate at voltages of 11 to 36 V DC. Higher voltage will damage the transmitter.

Connecting SITRANS LG200

! WARNINGS:

- Check the nameplate on your instrument, to verify the approval rating.
- Approved dust-tight and water-tight conduit seals are required for outdoor Type 4/ NEMA 4, IP65.

Notes:

- For detailed wiring instructions, please refer to the full Instruction Manual.
- Use shielded twisted pair cable: 0.5 to 1 mm² (AWG 22 to 18).
- Separate cables and conduits¹ may be required to conform to standard instrumentation wiring practices, or electrical codes.

Wiring

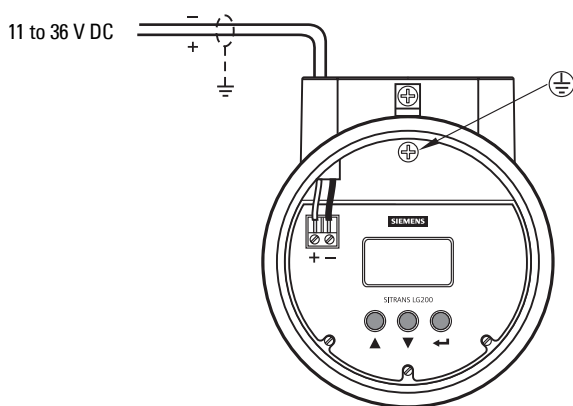

RUN Mode and PROGRAM Mode

SITRANS LG200 has 2 modes of operation: RUN and PROGRAM.

After powering up, the LG200 display changes every 2 seconds to show one of four values:

Status, Level, %Output, and Loop Current. In RUN mode, use arrow keys ▲ ▼ to switch from one display to another. The display can also be set to each display individually.

In RUN mode, press arrow keys ▲ ▼ to scroll to the parameter you would like to edit.

Press Enter ← to switch to PROGRAM mode (shows an exclamation point ! as the last character in the top display line.)

In PROGRAM mode, press arrow keys ▲ ▼ to increase or decrease the value displayed and to move to the next choice. Hold the arrow keys for rapid scrolling.

¹ If cable is routed through conduit, use only approved suitable-size hubs for waterproof application.

Quick start programming

1. Remove the cover of the electronics.
2. Use the Down (▼) arrow key to move from one step of the configuration program to the next.
3. Press the Enter (↵) key. The last character in the first line of the display changes to an exclamation point (!).
4. Use the Up or Down arrow keys ▲ ▼ to increase or decrease the value in the display or to scroll through the choices.
5. Press Enter (↵) to accept a value and move to the next step of the configuration process (the default password is 0).
6. To return to RUN mode, scroll to the display parameters (***Status***)
7. After entering the last value, allow 10 seconds before removing power from the transmitter (save function).

Password protection (Default = 0)

The SITRANS LG200 transmitter is password protected to restrict access to parts of the menu structure that affect the operation of the system. In **Program Mode**, when the proper password is entered, an exclamation point (!) is the last character of the first line of the display. The password can be changed to any numerical value up to 255. The password is required whenever configuration values are changed.

The default user password is 0. Enter a new password in the last step of the configuration menu. With a password of 0, the transmitter is no longer password protected and any value in the menu can be altered without entering a confirming password, except diagnostic values.

The device remains unprotected for five minutes without a button pressed, and then the password protection set is applied.

NOTE: If the user password is not known, the menu item New Password displays an encrypted value representing the present password. Call the factory with this encrypted value to determine the current password.

Activating SITRANS LG200

Power up the LG200. It begins in **RUN** mode and the display shows one of four read-only values every 2 seconds: Status, Level, %Output, and Loop Current.

Accessing a parameter

1. Use the **ARROW** keys ▲ ▼ to scroll to an editable parameter. Hold the Arrow keys for rapid scrolling.
2. Press **Enter** (↵) to select a parameter.
3. Use the **ARROW** keys ▲ ▼ to choose the parameter value.
4. Press **Enter** (↵) to accept a value and move to the next step of programming
5. The LCD displays the new parameter and value.

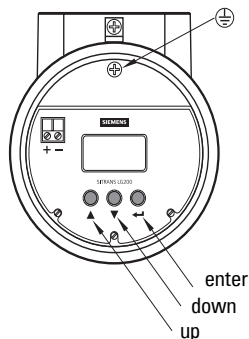

Quick Start programming

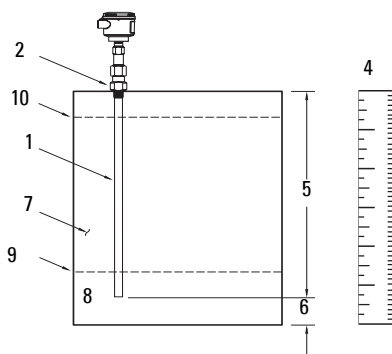

1. Probe Model [see Probe Nameplate (7MLxxx-x) (7xX) for details]: _____

2. Probe Mounting Type NPT, BSP, or flanged [use part number to establish Probe Mounting Type (NPT and BSP differ in insertion length)]: _____

3. Measurement Type (level only, volume, interface level, or interface level and volume): _____

4. Level Units (inches, centimeters, feet, meters): _____

5. Probe Length [listed on model information at top of probe (Note Y01 = xxx cm)]: _____

6. Level Offset (desired level reading when liquid is at the end of the probe): _____

7. Dielectric (dielectric constant range of process medium, upper layer dielectric for interface applications): _____

8. Loop Control (Is output current to be controlled by level or volume?): _____

9. Set 4.0 mA (What is the reference point for the 4.0 mA value?): _____

10. Set 20 mA (What is the reference point for the 20.0 mA value?): _____

Quick Setup: steps 1 to 10

1. Select Probe model (Default: 7xA-x)

Values	Select from: 7xA-x (7ML1301-1), 7xB-x (7ML1302-1), 7xD-x (7ML1301-2), 7xF-x (7ML1303-1), 7xF-E (7ML1303-1D), 7xF-F (7ML1303-1E), 7xF-4 (7ML1303-1J), 7xF-P (7ML1303-1H), 7xJ-x (7ML1303-2), 7xK-x (7ML1305-1), 7xP-x (7ML1301-3), 7xR-x (7ML1301-4), 7xS-x (7ML1301-5), 7xT-x (7ML1301-6), 7x1-x (7ML1304-1), 7x2-x (7ML1304-2), 7x5-x (7ML1302-2), 7x7-x (7ML1302-3)
--------	--

2. Select Probe mounting type (Default: NPT)

Values	NPT
	BSP
	Flange

3. Select Measurement type (Default: Lvl Only)

Values	Lvl	Select measurement type.
	Lvl&Vol	
	Ifc	
	Ifc&Vol	

4. Select Level units (Default: Inches)

Values	cm
	inches
	feet
	meters

5. Select Probe length (Default: 120.0 in)

Values	Probe Ln xxx.x. Probe length is printed on the nameplate and order information (in cm).
--------	---

6. Select Level offset (Default: 0 in)

Values	Range: -61 to 762 cm (-24 to 300"). Level offset is the distance from the probe tip to the desired zero level point. Enter the desired reading when the probe is dry.
--------	---

7. Select Dielectric (Default: 10 – 100)

Values	1.4 – 1.7	Select range bounding the dielectric constant of the media. The LG200 uses this dielectric setting to adjust the Sensitivity setting. Default setting is probe dependent (for 7ML1301-5, setting is fixed at 10–100; for interface module, 7ML1301-6 only, select from 3–10, 10–100).
	1.7 – 3	
	3 – 10	
	10 – 100	

8. Select Loop control (Default: Lvl)

Values	Lvl	Level	Select variable to control loop current.
	Lvl&Vol	Level and Volume	
	Ifc	Level or Interface level	
	Ifc&Vol	Level, Interface level, Volume, Interface volume	

9. 4 mA Setpoint (Default: 0.0 in or 0.0 gal)

Values	Set 4 mA xxx.x (Enter PV value for the 4 mA point).	Enter the level for 0% or 4 mA output. It may be lower or higher than the 20 mA point. If a 4 mA and 20 mA points are entered with the same value, the unit will read 3.8 mA when level is below the setpoints, and 20.5 mA when level is above the setpoints. A small transition zone [0 to 15 cm(6")] may exist at the top or bottom of the probe.
--------	---	---

10. 20 mA Setpoint (Default: 120.0 in or 396.3 gal)

Values	Set 20 mA xxx.x (Enter PV value for the 20 mA point).	Enter the level for 100% or 20 mA output. It may be lower or higher than the 4 mA point. If a 4 mA and 20 mA points are entered with the same value, the unit will read 3.8 mA when level is below the setpoints, and 20.5 mA when level is above the setpoints. A small transition zone [0 to 15 cm (6")] may exist at the top or bottom of the probe.
--------	---	--

Use the **ARROW** keys ▲ ▼ to return to **RUN** mode: basic setup is complete. Scroll through to display loop.

SITRANS LG200 Communications: HART

- You will need the full manual to acquire the list of applicable parameters.
- The HART Device Description (DD) may be obtained from the HART Communication Foundation at www.hartcomm.org
- We recommend that you use SIMATIC Process Device Manager (PDM) to program your instrument.

Maintenance

SITRANS LG200 requires no maintenance or cleaning under normal operating conditions. If cleaning becomes necessary under severe operating conditions:

1. Note the probe material and the process medium, and select a cleaning solution that will not react adversely with either.
2. Remove the device from service and wipe the probe clean using a cloth and suitable cleaning solution.

Unit Repair and Excluded Liability

For detailed information, please see the inside back cover.