

MINIRANGER PLUS

Instruction Manual PL-604

April 2001

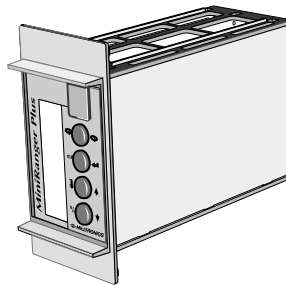

MINIRANGER PLUS

Safety Guidelines

Warning notices must be observed to ensure personal safety as well as that of others, and to protect the product and the connected equipment. These warning notices are accompanied by a clarification of the level of caution to be observed.

Qualified Personnel

This device/system may only be set up and operated in conjunction with this manual. Qualified personnel are only authorized to install and operate this equipment in accordance with established safety practices and standards.

Warning: This product can only function properly and safely if it is correctly transported, stored, installed, set up, operated, and maintained.

Note: Always use product in accordance with specifications.

Copyright Siemens Milltronics Process Instruments Inc. 2000. All Rights Reserved

Disclaimer of Liability

This document is available in bound version and in electronic version. We encourage users to purchase authorized bound manuals, or to view electronic versions as designed and authored by Siemens Milltronics Process Instruments Inc. Siemens Milltronics Process Instruments Inc. will not be responsible for the contents of partial or whole reproductions of either bound or electronic versions.

While we have verified the contents of this manual for agreement with the instrumentation described, variations remain possible. Thus we cannot guarantee full agreement. The contents of this manual are regularly reviewed and corrections are included in subsequent editions. We welcome all suggestions for improvement.

Technical data subject to change.

MILLTRONICS® is a registered trademark of Siemens Milltronics Process Instruments Inc.

Contact SMPI Technical Publications at the following address:

Technical Publications
Siemens Milltronics Process Instruments Inc.
1954 Technology Drive, P.O. Box 4225
Peterborough, Ontario, Canada, K9J 7B1
Email: techpubs@milltronics.com

For the library of SMPI instruction manuals, visit our Web site: www.milltronics.com

Table of Contents

General Information	5
About this Manual	5
About MiniRanger Plus	6
Specifications	7
Installation.....	11
Dimensions	11
Mounting	13
Interconnection	18
Synchronization	19
Communication	21
Start Up.....	25
General	25
Display and Keypad	26
Run Mode	27
Program Mode	28
Setting Up	29
Display Messages.....	31
Functional	33
Transceiver	33
Transducer.....	33
Temperature	33
Sound Velocity.....	34
Blanking	34
Loss of Echo	35
Relays	36
mA Output.....	40
Run / Program	41
Applications.....	43
Simple Level Application.....	44
Pump Control Application	46
High Level Switch	48
Applications with Standpipe.....	50
Volume Conversion	51
Open Channel Monitoring (OCM)	53
Parameter Description	55
Troubleshooting	71
Maintenance.....	74
Appendices	75
Alphabetical Parameter List.....	75

About this Manual

It is essential that this manual be referred to for proper installation and operation of your MiniRanger Plus. As MiniRanger Plus requires an ultrasonic transducer to make a working system, refer to the associated transducer manual as well.

<i>Installation</i>	gives you step by step direction for the installation and interconnection of your MiniRanger Plus.
<i>Start Up</i>	instructs you how to operate the keypad, program and read the display.
<i>Functional</i>	describes the functionality of the MiniRanger Plus, detailing the interoperation of the salient features, and highlights transceiver, relay and mA operation.
<i>Applications</i>	looks at the MiniRanger Plus from a practical point of view, using examples of the applications it is likely to encounter.
<i>Parameters</i>	lists the parameters available to you, with a description of their function and use. You are urged to read this section; to familiarize yourself with the parameters available to you, and get your MiniRanger Plus working to its fullest.
<i>Troubleshooting</i>	tabulates symptoms, causes and actions to common installation and application problems that you might encounter. Hopefully you will never have to read this section, but know it's there to help you.
<i>Appendices</i>	what manual would be complete without one! Ours is an alphabetical cross reference of the parameters and their numbers, and a record sheet for jotting down parameter values. Handy indeed!

About MiniRanger Plus

Note:

The MiniRanger Plus is to be used only in the manner outlined in this instruction manual.

MiniRanger Plus is a versatile material level monitoring instrument. Material level measurement is achieved using advanced sonic echo ranging techniques. The unit is complete with an integral multifunction liquid crystal display, a four button keypad and an integral junction box.

Remotely coupled to an appropriate transducer, MiniRanger Plus is well suited for short to medium range measurements of liquids or solids, in open or closed vessels. MiniRanger Plus is at home in a wide variety of industries: food, pharmaceutical, chemical, water, waste water - to name a few.

The MiniRanger Plus emits a series of ultrasonic pulses from the associated transducer. Each pulse is reflected as an echo from the material and sensed by the transducer. The echo is processed by the MiniRanger using Milltronics' proven 'Sonic Intelligence' techniques. Filtering is applied to help discriminate between the true echo from the material, and false echoes from acoustical and electrical noise and agitator blades in motion. The time for the pulse to travel to the material and back is temperature compensated and then converted into distance for display, mA output and relay actuation, and optional volume.

MiniRanger Plus is available in three physical styles for wall, rack or panel mounting.

MiniRanger Plus features:

- ✓ multi-field LCD for: parameter, reading and bar graph display, and relay and fail-safe status.
- ✓ two alarm / pump control relays
- ✓ high level switch operation
- ✓ lead / lag pump operation
- ✓ Dolphin compatibility
- ✓ isolated mA output
- ✓ Sonic Intelligence®
- ✓ integral keypad
- ✓ optional volume conversion
- ✓ optional open channel monitoring (OCM)
- ✓ illuminated display
- ✓ universal power supply

Rack and panel mount - additional features

- ✓ RS-232 direct Dolphin link
- ✓ bipolar communications loop

Specifications

MiniRanger Plus

Power

- 9-250 Vac, 40-70 Hz, 38 VA, 12W or 9-250 Vdc, 11W

Fuse

- F1 2AG, SlowBlow, 2 amp, 250 V
- F3 2 AG, SlowBlow, 1 amp, 250 V
- F4 Belling Lee, L754, 4000A HRC, ceramic type 100 mA, 250V

Environmental

- wall / rack / panel specific

Range

- solids applications: 7.5 m (25 ft.) (transducer dependent)
- liquid applications: 15 m (50 ft.) (transducer dependent)

Accuracy

- 0.25% of range or 6 mm (0.24"), whichever is greater

Resolution

- 2 mm

Memory

- program stored in non-volatile FLASH memory, for software upgrades via optional Dolphin interface
- parameters stored in non-volatile EEPROM

Display

- wall / rack / panel specific

Outputs

Transducer Drive

- 43.5 kHz, 250 V peak pulses of 1 ms max. duration at max. repetition rate of 300 ms

mA

- optically isolated 0/4 - 20 mA
- max. loading: 750 Ω
- resolution: 0.1% of 20 mA

Relays

- 2 alarm/pump control relays
- 1 form 'C' SPDT contact per relay, rated 5 A at 250 Vac non-inductive

Communication

- wall / rack / panel specific

Approvals

- CE¹, FM, CSA_{NRTL/C}

¹ EMC performance available upon request.

Wall Mount

Environmental

- location: indoor/outdoor
- altitude: 2000 m max.
- ambient temperature: -20 to 50°C (-5 to 122°F)
- relative humidity: suitable for outdoor (Type 4X / NEMA 4X / IP 65 enclosure)
- installation category: II
- pollution degree: 4

Display

- 38 x 100 mm (1.5 x 4") multi-field backlit liquid display

Communications

- Dolphin Plus compatible via optional Milltronics ComVerter

Enclosure

- Type 4X/NEMA 4X/IP65

Weight

- 1 kg (2.2 lb.)

Rack and Panel Mount

Environmental

- location: indoor
- altitude: 2000 m max.
- ambient temperature: -20 to 50°C (-5 to 122°F)
- relative humidity: 80% for temperature up to 50°C (122°F)
- installation category: II
- pollution degree: 2

Display

- 75 x 20 mm (3 x 0.8") multi-field liquid crystal display

Communications

- Dolphin Plus compatible via RJ-11 phone jack/RS-232

Enclosure

- **Rack Mount:**
DIN 3U/14HP, 4 rail plug in unit suitable for standard 84HP (19") sub rack
- **Panel Mount:**
suitable for DIN 43700, 72 x 144 standard panel cut-out

Weight

- 0.5 kg (1.1 lb.)

Transducer

Compatible models:

- ST-25 / 50 Ultrason[®], STH and Echomax[®] models XRS-5, XKS-6, XPS-10, XPS-15, XCT-8 and XCT-12.
- Refer to the associated transducer manual.

Cable

Transducer:

- RG-62 A/U (or equivalent), 365 m (1,200 ft) max.
- See transducer Instructions for short extensions (in grounded metal conduit, separate from other wiring)

mA Output:

- Belden 8760, shielded / twisted pair, 18 AWG (0.75mm²) or equivalent
- Maximum separation 1,500 m (5,000 ft)

Synchronisation:

- Belden 8760, shielded / twisted pair, 18 AWG (0.75mm²) or equivalent

Relays:

- No shielded cable necessary.

Bipolar current loop (Rack & Panel Only):

- Belden 8760, shielded / twisted pair, 18 AWG (0.75mm²) or equivalent
- Maximum separation 1,500 m (5,000 ft)

RS-232 Link (Rack & Panel Only):

- Belden 8760, shielded / twisted pair, 18 AWG (0.75mm²) or equivalent
- Maximum cable length 10 m (50 ft)

RJ-11 Link (Rack & Panel Only):

- No shielded cable necessary.
- Maximum cable length 3 m (10 ft)

Installation

Notes:

- Installation shall only be performed by qualified personnel and in accordance with local governing regulations.
- This product is susceptible to electrostatic shock. Follow proper grounding procedures.

Dimensions

Wall Mount

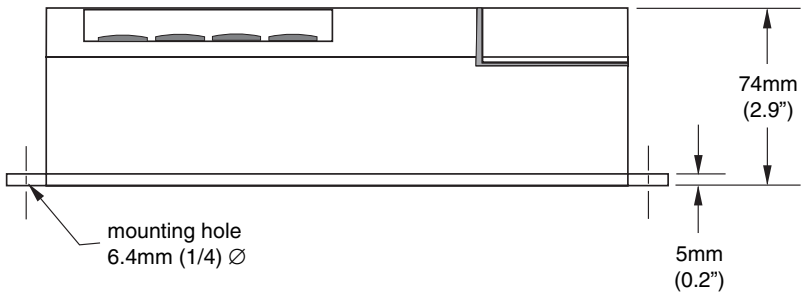
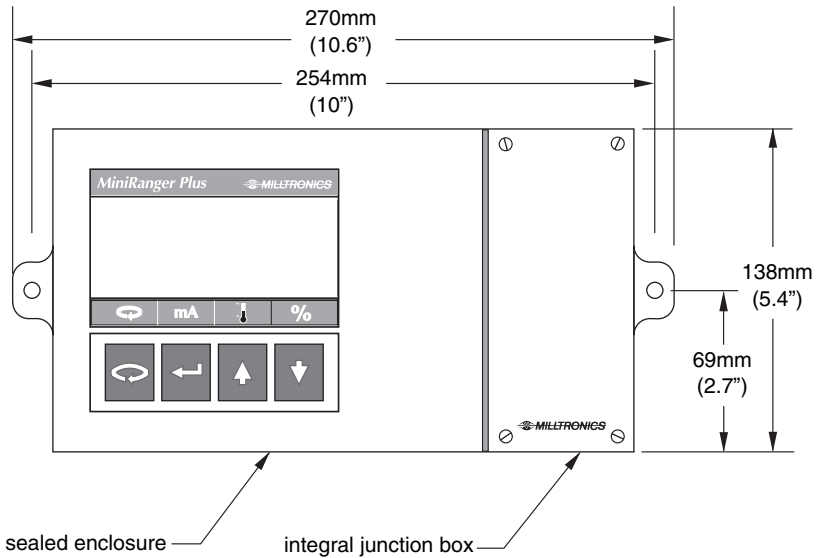

Installation

Rack Mount

The MiniRanger Plus rack mount version is a standard DIN 3U/14 HP, 4 rail plug-in unit, for a standard 84 HP deep sub-rack.

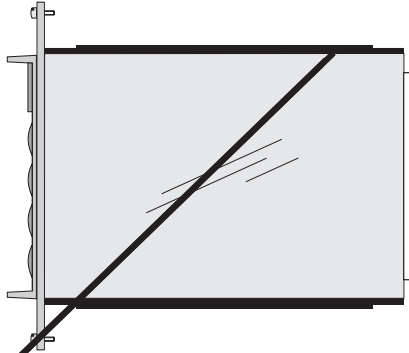
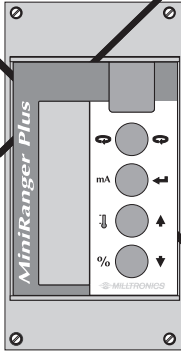

Panel Mount

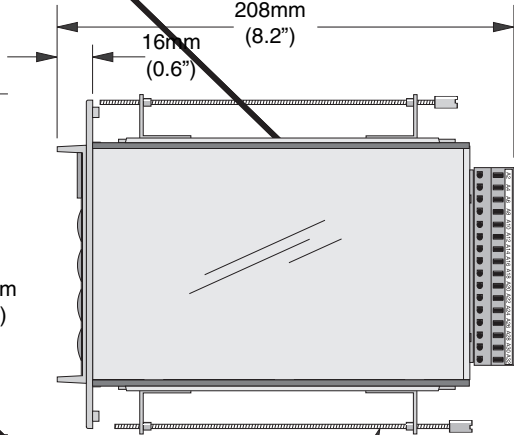
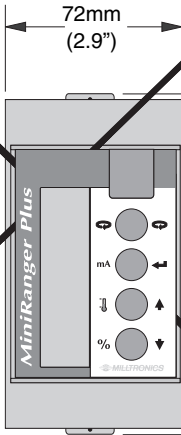

slip on mounting bracket top and bottom screws to be tightened to no more than 1 inch / lb. torque

Installation

Mounting

Wall Mount

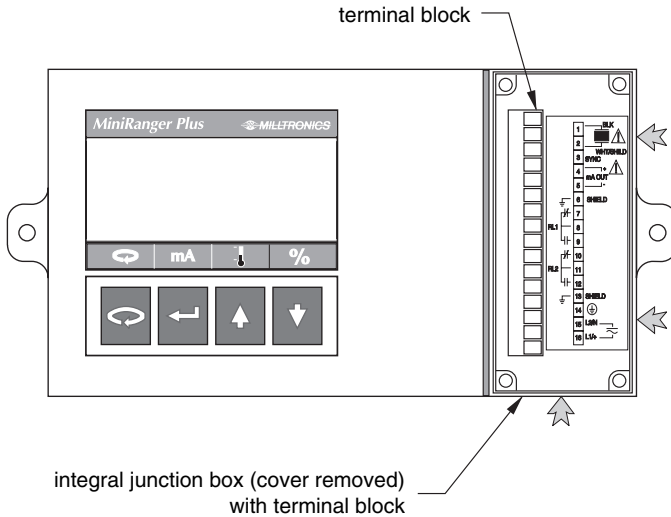

➔ Conduit entry location. Recommend drilling the enclosure with a hole saw and the use of suitable cable glands to maintain ingress rating

Terminal Block Layout (Wall Mount)

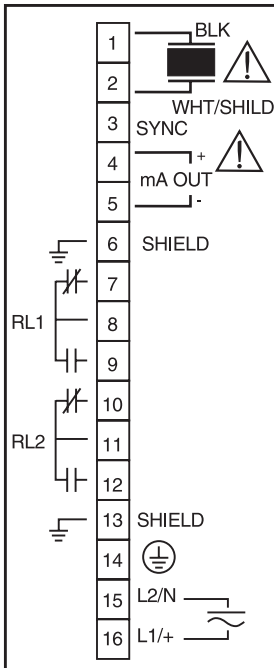

Notes:

Non metallic enclosure does not provide grounding between connections. Use grounding type bushings and jumpers



All field wiring must have insulation suitable for at least 250 V.



Hazardous voltage present on transducer terminals during operation.

Relay contact terminals are for use with equipment having no accessible live parts and wiring having insulation suitable for at least 250 V.

Rack Mount

1. Slide the MiniRanger Plus into the sub-rack, aligning the connector with the rail mounted terminal block.

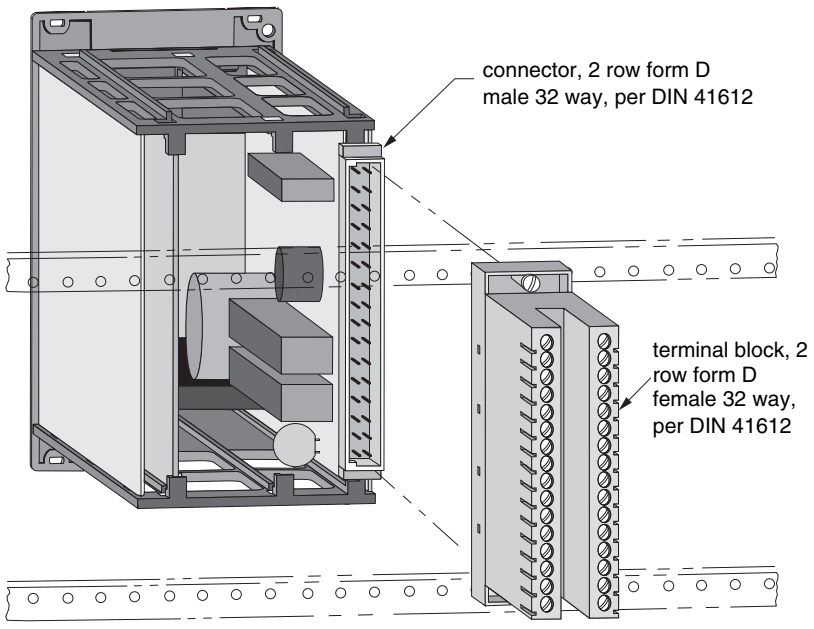

2. Push the MiniRanger Plus into the sub-rack until the MiniRanger Plus front cover is snug to the front rails.
3. Tighten the 4 captivated screw to secure the MiniRanger Plus in place.

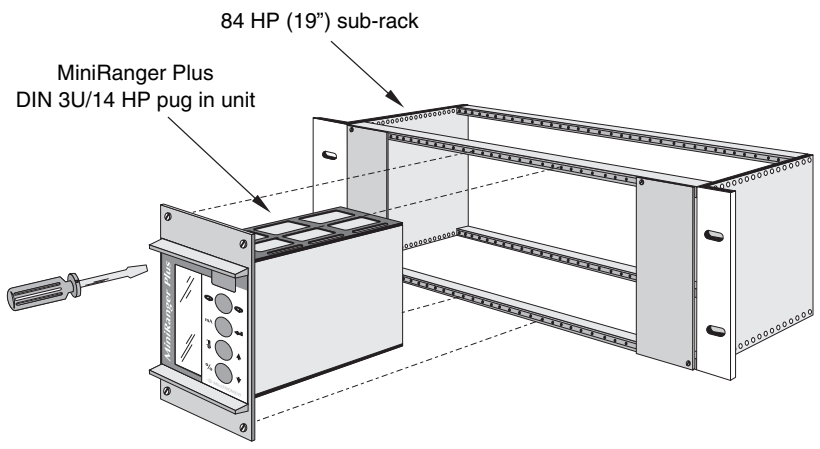

blanking panels must cover any unused slots

Installation

Terminal Block Layout (Rack Mount)

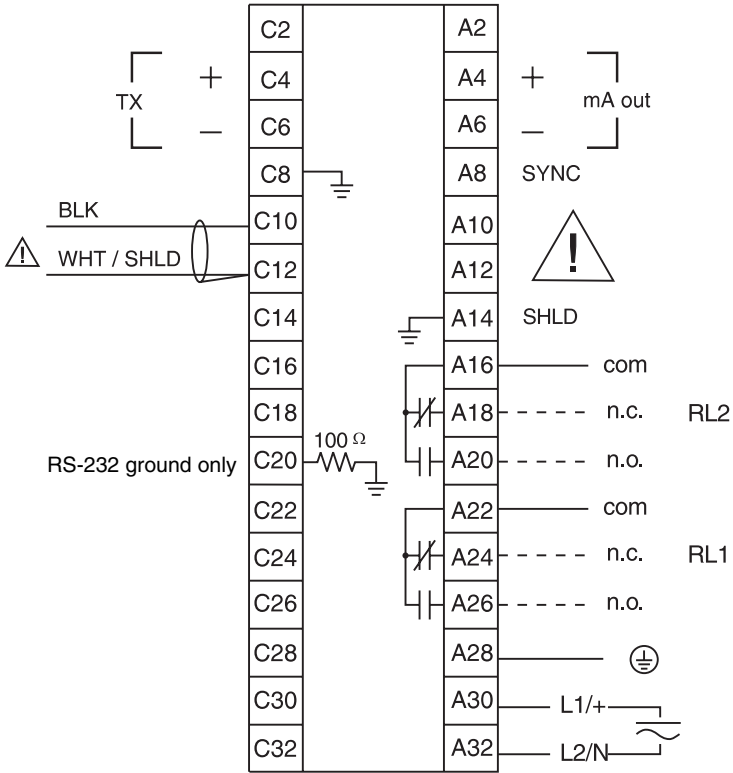

Warning:



All field wiring must have insulation suitable for at least 250V.



Hazardous voltage present on transducer terminals during operation.

Installation

Panel Mount

1. Slide the MiniRanger Plus through the panel cut-out.
2. Assemble mounting brackets to the MiniRanger Plus chassis by hooking them into the top and bottom.

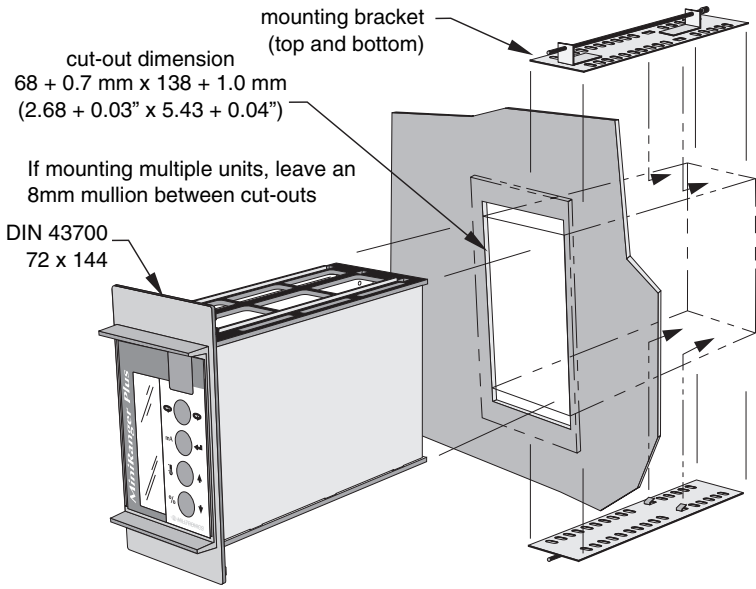

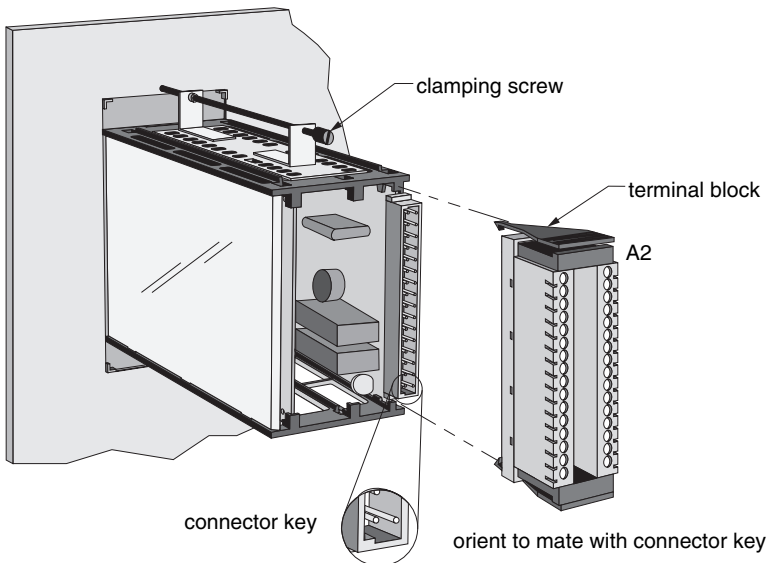

3. Tighten mounting bracket clamping screw (top & bottom)
4. Plug the terminal block into connector socket.

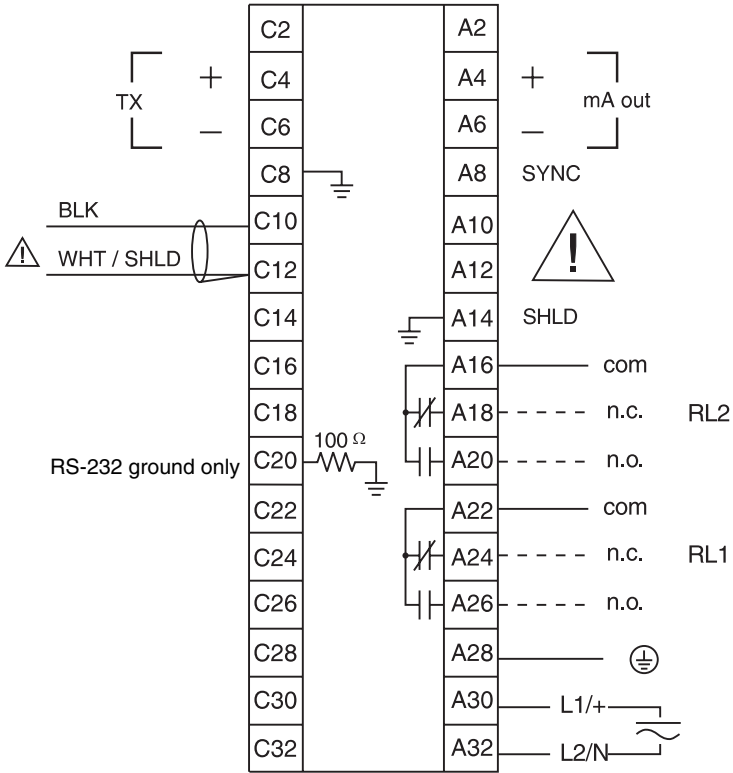

Terminal Block Layout (Panel Mount)



Warning:

-  All field wiring must have insulation suitable for at least 250V.
-  Hazardous voltage present on transducer terminals during operation.

Installation

Interconnection

System Diagram

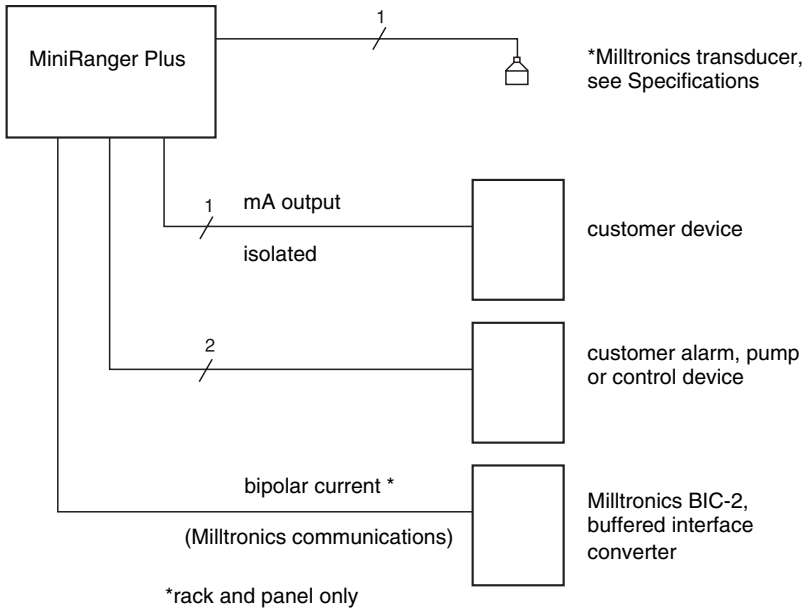

Installation

Transducer

Wall Mount

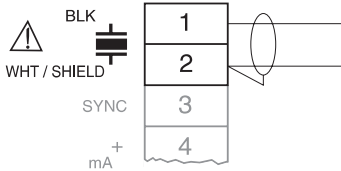

Rack and Panel Mount

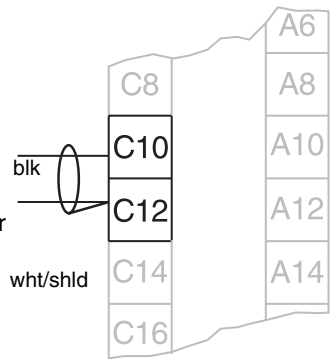

Note:

Refer to transducer instruction manual for location and mounting details.

Synchronization

In applications where more than one MiniRanger Plus, to a maximum of 8, are going to be used or where their transducers are sharing a common conduit, synchronization is required. When synchronized, no device transmits within 180 ms of the prior one(s).

To synchronize, interconnect the SYNC terminals of all devices and ensure that there is a common electrical ground interconnecting all units.

To synchronize MiniRanger Plus with other Milltronics products, consult Milltronics or your distributor.

Wall Mount

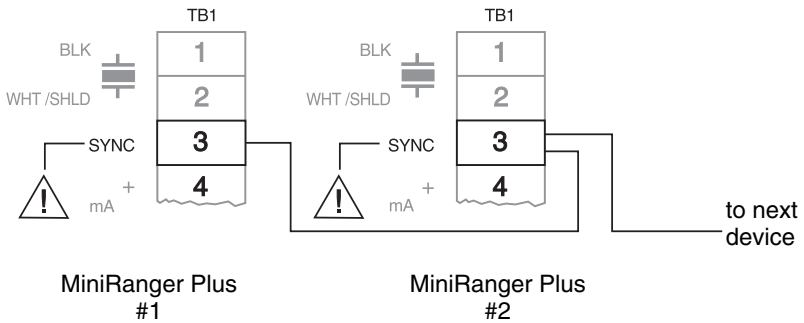

Rack and Panel Mount

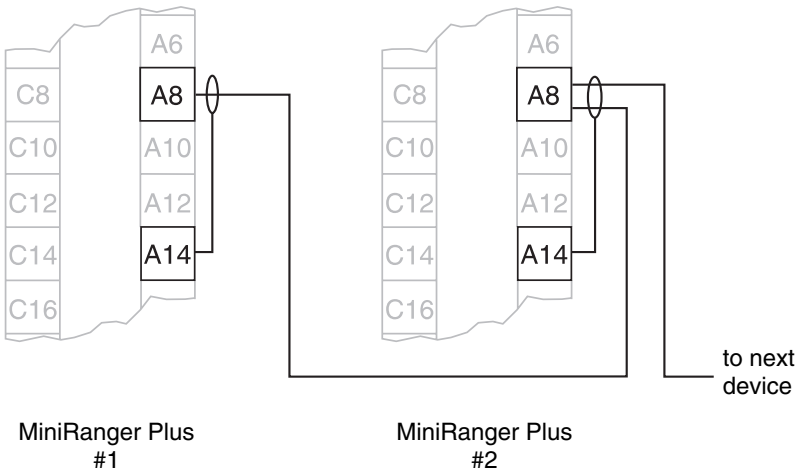

Current Output

Wall Mount

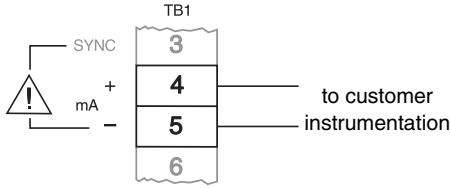

isolated mA output, 750 Ω max load

Rack and Panel Mount

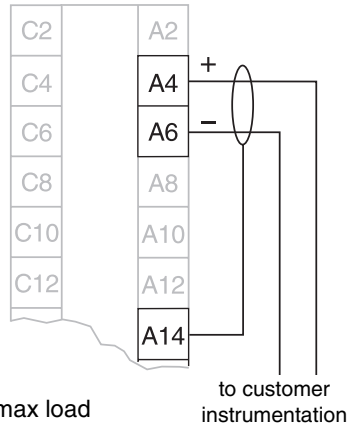

Relay Output

Wall Mount

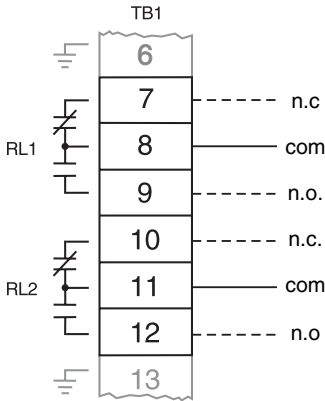

Rack and Panel Mount

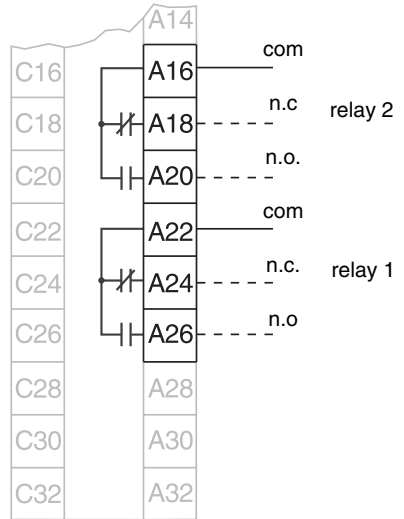

relays shown in de-energized state, contacts rated 5 A at 250 V non-inductive

Note:

All relays are certified for use in equipment where the short circuit capacity of the circuits in which they are connected is limited by fuses having ratings not exceeding the rating of the relays.

Communication

Rack and Panel Mount (only)

Bipolar and RS-232 communication are both achieved through a common 'TX' port terminal C4 and C6, without any hardware or software intervention.

IBM PC Computer Connection / RS-232

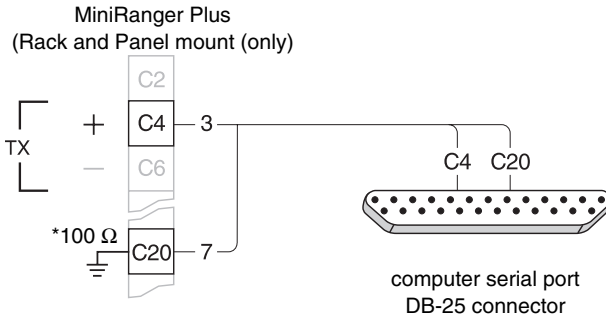
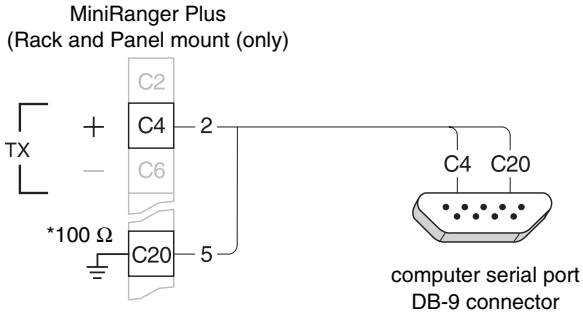

* C20 has 100Ω internal resistance to ground to avoid ground loops

BIC-2 Connection / Bipolar Current

MiniRanger Plus Rack and Panel mount

BIC-2

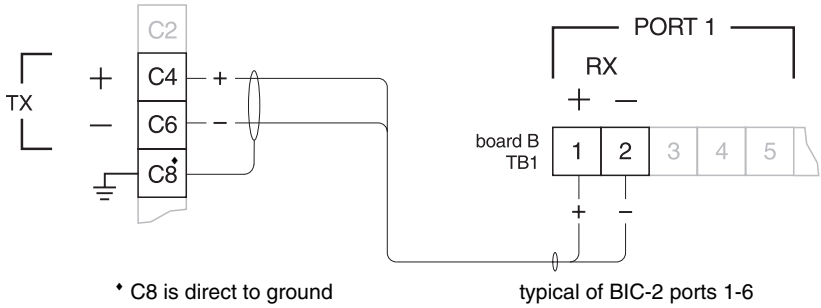

Note:

Ground shield at one end only

Power

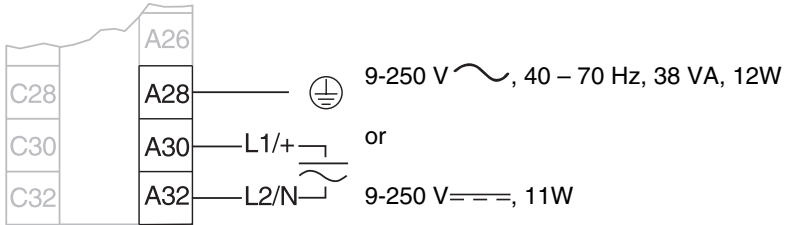

Note:

A circuit breaker or switch in the building installation, marked as the disconnect switch, shall be in close proximity to the equipment and within easy reach of the operator.

Wall Mount only

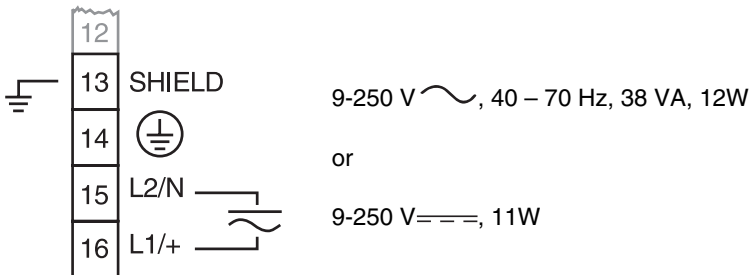

Dolphin

Optional Dolphin Interface

Wall Mount

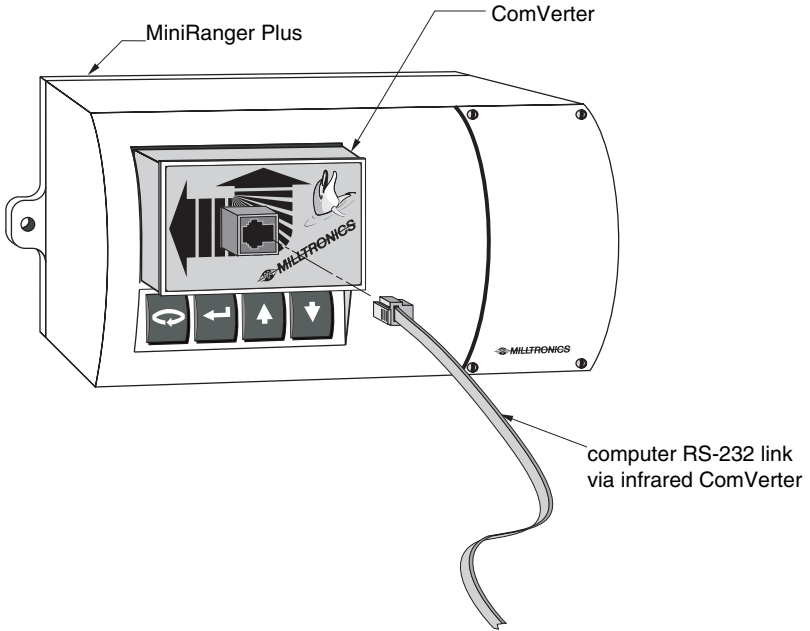

Rack and Panel Mount

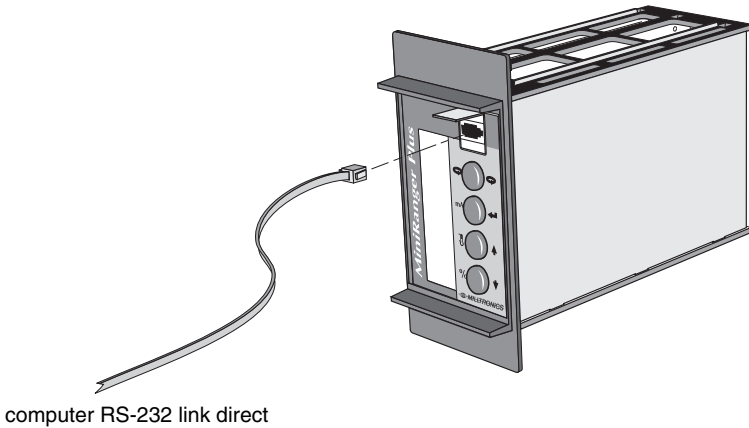

Note:

Refer to Dolphin instruction manual for interconnection details.

Start Up

General

The MiniRanger Plus has two modes of operation: *run* and *program*. When the unit is powered, after installation procedures have been completed, it is programmed to start up in the run mode, to detect the distance from the transducer face to the target in meters.



typical display
(wall mount)

The unit can be placed into the program mode at any time; to alter a number of program parameters in order to better suit the application or user's preferences. Programming can be carried out via the local keypad or the optional Dolphin infrared interface.

The first step when programming is to reset all parameters to their factory setting by using the master reset P-999. This must be done via the local keypad.

For a Quick Start, P001 to P007 are the key parameters requiring entry.

They set:

- mode of measurement
- process material
- transducer type
- measurement response
- units
- empty distance
- span

There are a number of other program parameters, especially relay and mA output, that can be changed subsequently or during another programming session. Refer to Parameter List for a description of the parameters available.

When programming has been completed, the MiniRanger Plus can be put into normal operation by pressing .

Display and Keypad

Wall Mount

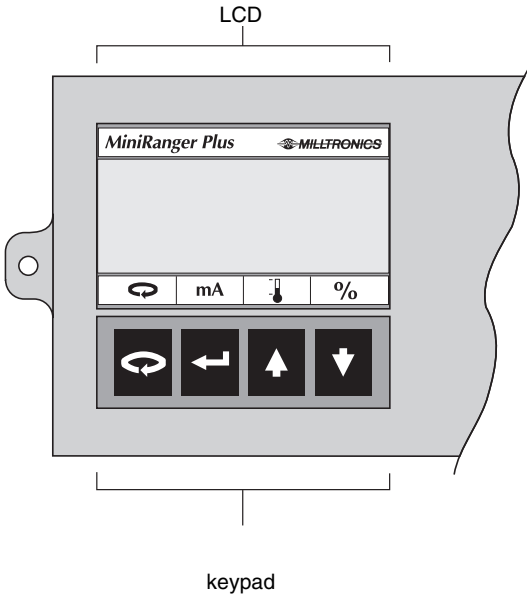

Rack and Panel Mount

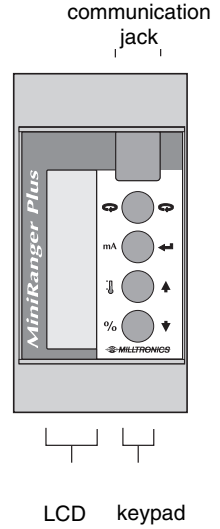

Start Up

Run Mode

LCD

Wall Mount

Rack and Panel Mount

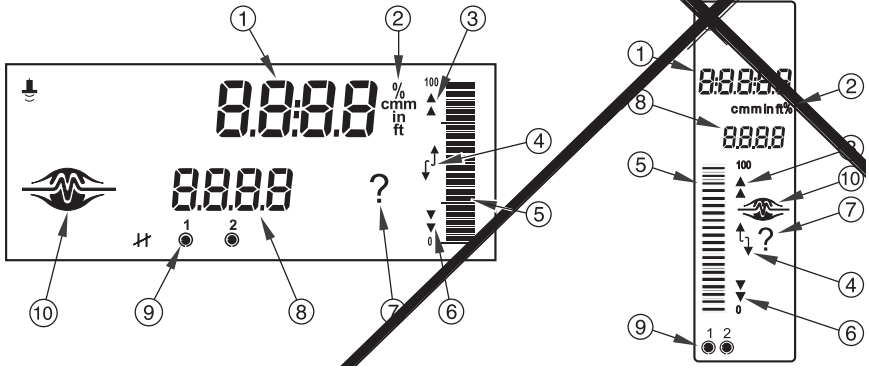

1. reading
2. units
3. high alarm indicators: ▲ = high, ▲▲ = high-high
4. process material level rising or falling
5. bar graph representation of material level, 0 to 100% of span
6. low alarm indicators: ▼ = low, ▼▼ = low-low
7. reading questionable, appears during fail-safe operation
8. auxiliary reading
9. relay status
10. = normal operation = fail-safe operation

Keypad

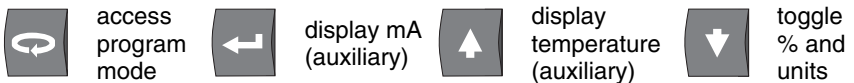

Start Up

Program Mode

LCD

Wall Mount

Rack and Panel Mount

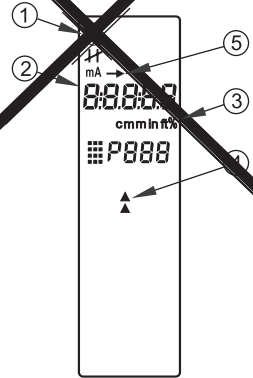
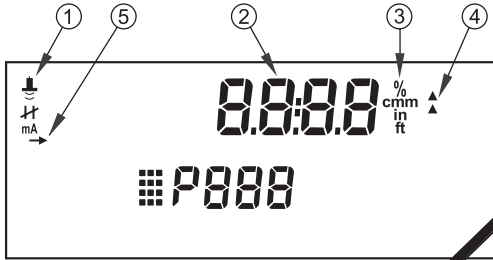

1. parameter type (transducer, relay, or mA output)
2. reading
3. units
4. 'change value' accessed
5. breakpoint accessed

Keypad



access
run mode



alternates program
mode between
'select parameter'
and 'change value'
functions



scroll up



scroll
down

Setting Up

Programming depicts the wall mount LCD. Display for the rack and panel mount units is the same except for the position of readings and icons.

To Access Program:



run display

Press 



program starts at P001

To Select a Parameter :

Press 

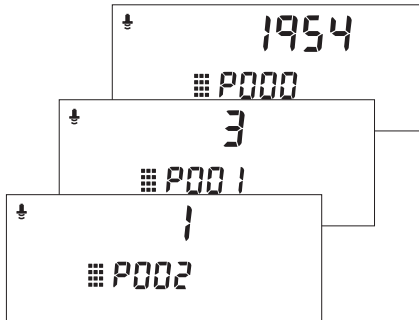

To Change a Parameter Value :



select parameter, e.g. P001 =3

Press 

initiate change function



Note:
Security must be disabled!

Press 

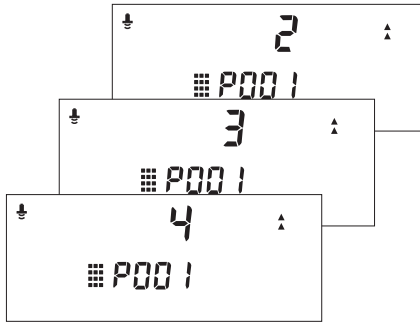

increase or decrease to the desired value.

if no response, security not disabled!

Press 

save and return to 'select parameter' function,

Note:
Must be pressed to Save change!

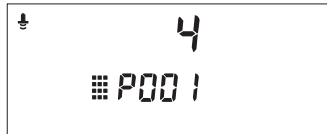

e.g. p001 =4

Express:

Parameter:

to jump back to P001, or

Value:

to jump to the factory setting.



e.g. P999



jump back to P001



To Return to Run Mode



from the program mode
e.g. P001

Press 



exit and return to
run mode.

Display Messages



'OPEN' in
transducer circuit.
Refer to
Troubleshooting.



'Short' in
transducer circuit
or wiring reversed.
Refer to
Troubleshooting

Express Viewing

To view the following readings while in run mode, simultaneously press the depicted keys.

Echo Confidence (P805)



Echo Strength (P806)



Noise (P807)



Distance (P923)



Transceiver

The MiniRanger Plus transceiver operates under 1 of 5 sets of preset conditions (P003), summarized as follows:

parameter value	measurement response		echo verification	filter	f-s timer* (P070)	long pulses*
1	0.1 m/min	(slow)	on	on	100	2
2	1 m/min	▪	on	on	10	2
3	10 m/min	▪	on	on	1	2
4	102 m/min / 1.7 m/sec	▪	off	on	0.1	1**
5	1020 m/min / 17 m/sec	(fast)	off	off	0	1**

*each measurement consists of one short pulse plus the set number of long pulses.

**set number of long pulses, only if required.

When a measurement is initiated, the set number of short and long pulses is transmitted. Short pulse measurements are restricted to the first 2 m range extending from the transducer face. When a short pulse is combined with a long pulse set, the short pulse range is restricted to 1 m and the long pulse covers the full measurement range.

When the echo of the transmitted pulse train is received, the relevant echo extraction technique (P820), is applied to determine the true material echo. The measurement response limits the maximum rate at which the display, mA output and relay contacts respond to changes in measurement. It is of concern especially where liquid surfaces are in agitation or material falls into the sound path during filling.

Transducer

The transducer, which is connected to the transceiver and mounted remotely at the measurement site, converts the electrical energy of the transmit pulse into acoustical energy and converts the acoustical energy of the echo back into electrical energy for the transceiver receive period.

Some transducer models incorporate an integral temperature sensor. The echo and temperature signals share the same cable wiring, then segregated at the transceiver.

Temperature

In order to compensate for uniform temperature changes of the sound medium, temperature sensing is achieved using a transducer with an integral sensor.

If the transducer does not have an integral sensor, temperature compensation is fixed at a programmed value, P661. The difference between the fixed value and the actual temperature surrounding the transducer will cause an error in measurement.

Sound Velocity

The MiniRanger Plus can be calibrated to compensate for sound velocity error in fixed temperature, homogenous atmospheres.

The basis is to physically measure the level (measuring tape or sight glass) and enter the value via P651. The MiniRanger Plus then calculates the sound velocity by comparing the entered physical measurement to its own ultrasonic measurement.

Blanking

Near blanking (P800) is used to ignore the zone in front of the transducer where ringdown* or other false echoes (e.g. standing wave, ladder rung) appear as an echo during the receive cycle. This is usually indicated by an incorrect high level reading and can be overcome by increasing the near blanking from its factory set value.

* ringdown is the natural decay of transducer vibration after the transmit pulse ceases.

Far end blanking is a feature that ignores the zone below the zero or empty level where false echoes can appear at levels that interfere with the processing of the true echo.

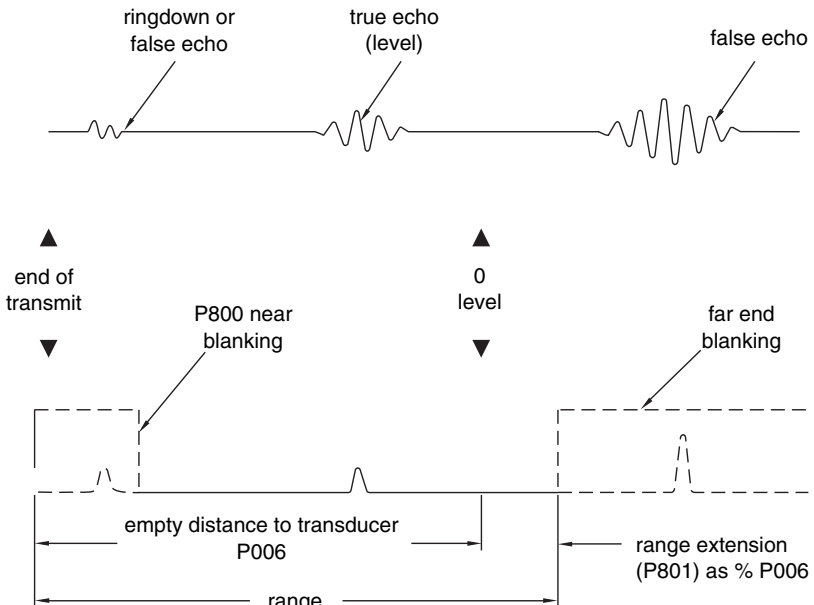

In applications where the zero level is above the bottom of the vessel and it is desired to monitor the zone below the normal zero, range extension (P801) can be used to extend the range into the far end blanking. Range extension is entered as a percent of P006. As range extension reduces the protection afforded by the far end blanking, it should be used judiciously. Avoid excessive range extension as this can reduce the measurement's reliability and accuracy. Range extension is factory set for 20% of P006. If it is found that false echoes are appearing ahead of the blanking zone, P006 should be reduced accordingly.

Blanking is automatically corrected for sound velocity change where temperature and velocity compensation are used; keeping the blanking at the distance at which it is set.

Loss of Echo

A loss of echo occurs when the MiniRanger Plus deems that the calculated measurement is unreliable, i.e. the echo confidence (P805) is less than the threshold (P804). This can be due to such circumstances as high level of electrical noise, poor grounding or poor transducer aiming. Refer to Troubleshooting. If the condition persists for a time beyond the limit as set by the fail-safe timer (P070), the confidence icon changes from full to partial and the reading and mA output are forced to the fail-safe default (P071) at the response rate (P003).

Upon receiving a reliable echo, the loss of echo condition is aborted (icon returns to full) and the reading, mA and relay output return to the present level at the response rate.

Relay operation responds, as programmed, to the default level as though an actual material reading.

Relays

General

Two onboard relays are provided in the MiniRanger Plus. Each relay can be assigned one of two functions: Alarm or Pump. Relay two can also be used to control a totalizer when the unit is in OCM mode.

Functions

Alarm

Note:

Alarm relays are de-energized in alarm condition.

high alarm : occurs when the level rises to the on setpoint. The alarm is cancelled when the level reaches the off setpoint.

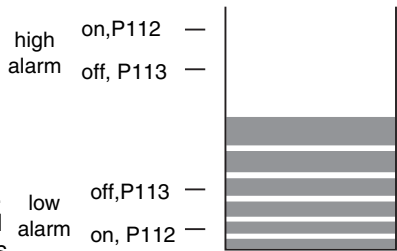

low alarm : occurs when the level falls to the on setpoint. The alarm is cancelled when the level reaches the off setpoint.

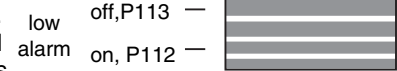

Pump

Note:

Pump relays are energized in pump condition.

pump down : occurs when the level rises to the on setpoint. The pump is stopped when the level reaches the off setpoint.

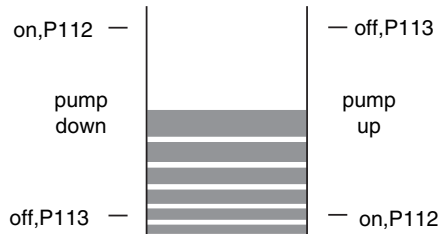

pump up : occurs when the level falls to the on setpoint. The pump is stopped when the level reaches the off setpoint.



pump sequencing: pumps 1 and 2 operate in lead lag fashion alternating roles on successive pump cycles (first pump on, to all pumps off) . Specifically, pump 1 responds to relay 1 setpoints and pump 2 responds to relay 2 setpoints during the first pump cycle. During the second cycle, pump 2 responds to relay 1 setpoints and pump 1 responds to relay 2 setpoints.

Note:

Relays programmed for pump control will not energize within 10 seconds of a MiniRanger Plus power up, or within 10 seconds of each other.

Open Channel Monitoring (OCM)

Note:

OCM calculation is an optional feature. MiniRangers with the OCM feature have this icon on the front: .

Relay 2 is automatically set to run an external totalizer when the unit is programmed for OCM. See Open Channel Monitoring (OCM) on page 53 for programming details.

Relay 1 can still be programmed normally when OCM is used.

Setpoints

Relay setpoints are in the units as programmed (P005).

Operation, P001 = 1, 2 or 3

The setpoints are measured from the bottom up, referenced to zero or empty (P006).

Operation, P001 = 4

The setpoints are measured outward from the transducer face.











Status

Programming

Upon entering the program mode, the alarm relays hold their prior status, pump relays are held off.

Relay programming: - select relay & function (P111)
- enter setpoints (P112 & P113)

•
•
•

		relay 1 function e.g. 0 = off
Press 		relay 2 function e.g. 0 = off
Press 		relay 1 on setpoint
Press 		relay 2 on setpoint
Press 		relay 1 off setpoint
Press 		relay 2 off setpoint

Run

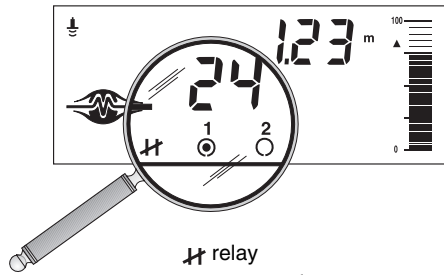

Fail-safe

When the fail-safe timer (P070) expires, the relays respond as follows*:

Fail-Safe Mode (P071)	Status			
	high alarm	low alarm	pump down	pump up
high	on	off	on	off
low	off	on	off	on
hold	hold	hold	hold	hold

* not applicable to high level switch operation, P001 = 4. In such cases, the timer is bypassed and the mode is always 'low'.

mA Output

The MiniRanger Plus can be programmed to provide an mA output (P200) of 0 to 20 or 4 to 20 mA, and for proportional or inverse span.

Programming

Upon entering the Program mode, the mA output level holds its prior value.

Run

The mA output responds in the following manner:

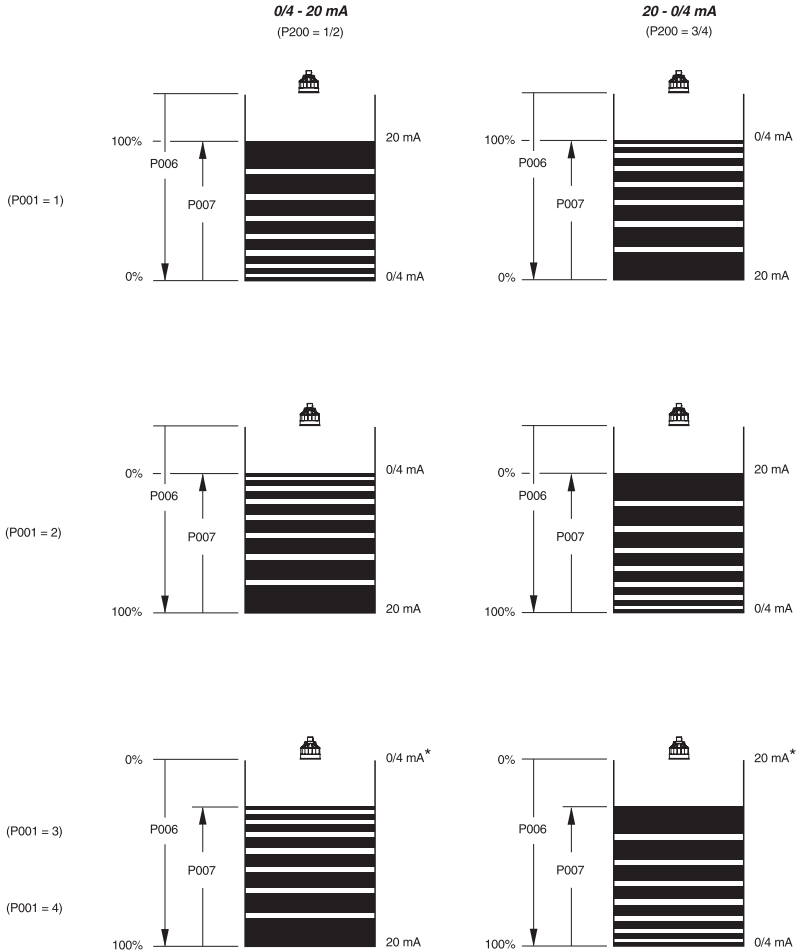

* reference value only. mA level limited by near blanking.
0 and 100% are percentage of full scale reading (m, cm, mm, ft, in)

Volume

Note:

Volume calculation is an optional feature. MiniRangers with the volume feature have this icon on the front: .

If reading is programmed for volume, P050 entry other than 0, then the mA output is proportional to volume.

To program the unit for volume, set:

- operation (P001) to level “1” (see page 55),
- tank shape (P050) to a value other than “0” (see page 57),
- other volume parameters (P051 to P053) as required.

Fail-safe

When the fail-safe timer (P070) expires, the mA output responds as follows *

Fail-safe Mode (071)	Status	
	0/4 – 20	20-0/4
high	20	0/4
low	0/4	20
hold	hold	hold

* not applicable to high level switch operation, P001 = 4. In such a case, the measurement immediately defaults to a low value.

Run / Program

When the MiniRanger Plus changes from run to program, the transceiver stops operating and the last measurement is stored; the associated reading, alarm status and mA output are held (pump control relays are turned off). As a courtesy, the unit reverts to the parameter last addressed during the previous program session. During program, the unit does not respond to the process unless the calibration parameters (P650 and P651) are accessed.

Note:

If the calibration parameters are accessed, only the reading becomes responsive.

Upon return to run, the transceiver resumes operation. The reading and associated outputs default to the last measurement taken, either during the previous run session or as a result of having accessed a calibration parameter. The reading and associated outputs migrate to the current process level at a rate controlled by the measurement response (P003).

This section highlights the most common applications to which the MiniRanger Plus is likely to be applied. Other applications not described here, such as position monitoring of a piston on a wood pulverizer, are basically improvisational and imaginative ways of applying the MiniRanger Plus. The trick is knowing the parameters available to you, and their limitations. Refer to the Parameter Descriptions that start on 55.

When programming, refer to the application which is most similar to yours. A practical example has been given to further expand on the programming features. As the example may not completely cover your application, again, it is important that you familiarize yourself with the list of available parameters.

Note:

The minimum distance from the transducer face to the target is limited by the minimum range of the transducer connected.

Simple Level Application

One of the most common applications of a Milltronics process material level monitor is simple level measurement, whereby the material level or space between the transducer and reflecting surface is measured and displayed. This may or may not include alarms and mA output.

Example

The application is to obtain a level measurement and corresponding 4-20 mA output proportional to material level in a gravel bin. The transducer face is 5 m from the bin bottom. The empty level is 0 m (bottom) and the full level (span) is 4.5 m from the bottom. A high alarm is required at 4 m from the bottom and a low alarm is required at 1 m from the bottom. The maximum rate of filling or emptying is about 1 m/min. In the event of a loss of echo, the MiniRanger Plus is to go into fail-safe low after 2 min.

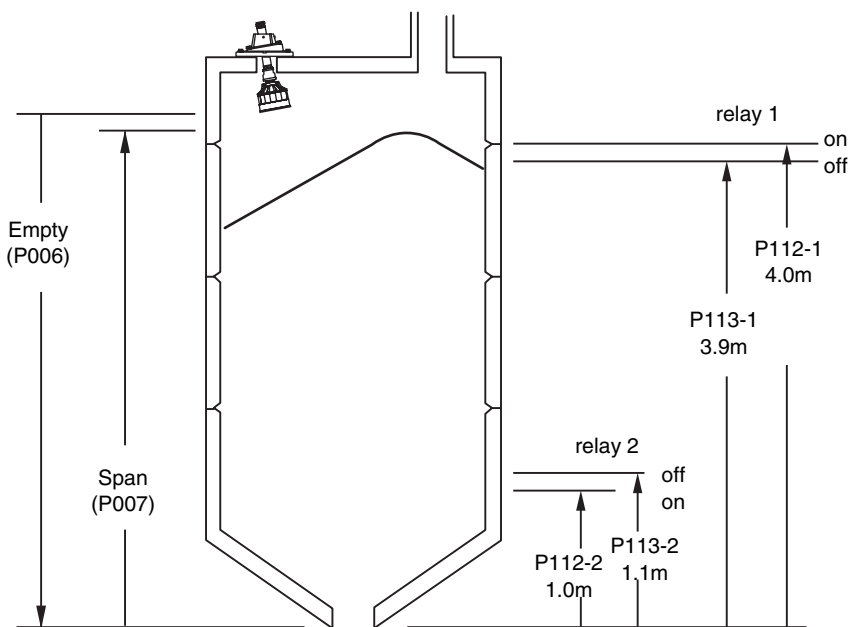

	Parameter	Directions	Description	
Run	P999		master reset	
	P001	enter '1'	mode of measurement = level	
Program	P002	enter '2'	material = solids	
	P003	enter '2'	measurement response = 1 m/min.	
	P004	enter `102'	the transducer model purchased with this system is an XPS-10	
	P005	enter `1'	units = metres	
	P006	enter `5'	empty distance = 5 m	
	P007	enter `4.5'	span = 4.5 m	
	P070	enter `2'	fail-safe timer = 2 min	
	P071	enter `2'	fail-safe = low	
	P111-1	enter `1'	level alarm, relay 1	
	P111-2	enter `1'	level alarm, relay 2	
	P112-1	enter `4'	relay 1, on setpoint = 4 m	
	P112-2	enter `1'	relay 2, on setpoint = 1 m	
	P113-1	enter `3.9'	relay 1, off setpoint = 3.9 m (nominal value, 0.1 m deadband)	
	P113-2	enter `1.1'	relay 2, off setpoint = 1.1 m (nominal value, 0.1 m deadband)	
	P200	enter `2'	mA output = 4 - 20	
	Run			press run to start normal operation

Pump Control Application

The basic difference between a simple level application and a pump control application is that the relays assigned to pump function (P111) are normally de-energized (off) and energized when required to run the pump. In the program mode, pump relays are held de-energized.

Pumps can be programmed to work independently or in lead/lag fashion. Refer to 36.

In applications where flooding is possible, a submersible transducer should be used. The submersible transducer's air cavity insures that a high level reading is maintained rather than establishing a loss of echo condition, when the liquid level reaches the transducer. When using a submersible transducer, set P802 = 1.

Example

The application is to control the level in a wet well. It is required that the level be displayed in centimetres. The transducer is mounted at 3.6 m from the bottom and is equipped with a submergence coupling as there is possibility of flooding in the well. Two pumps are to be controlled by the MiniRanger Plus in lead / lag fashion. The first pump to start at 1 m and the second pump to start at 2 m. Both pumps are to stop at 0.25 m. The maximum estimated filling rate is 1 m/min. In the event of a loss of echo, a fail-safe low after 6 sec is required to protect the pumps from running dry.

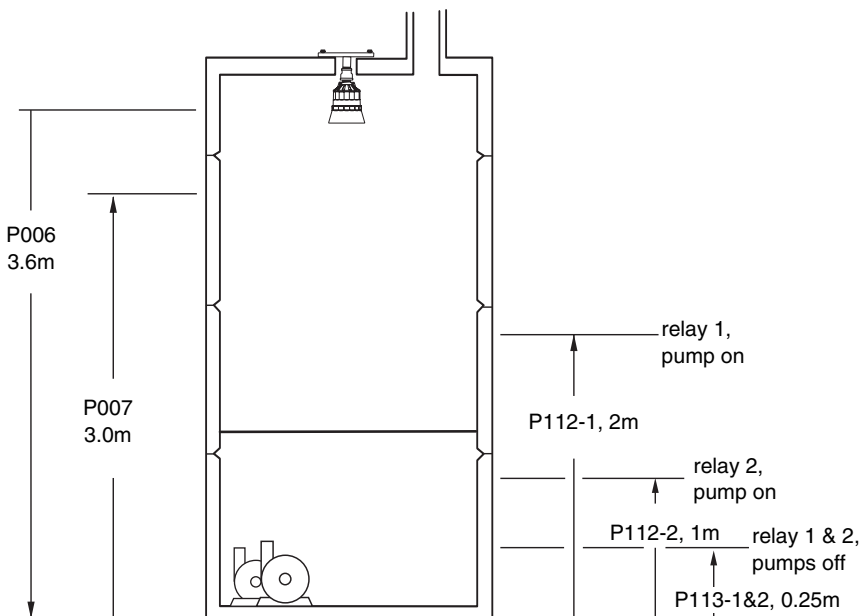

	Parameter	Directions	Description
Reset	P999		master reset
	P001	enter `1'	mode of measurement = level
Program	P002	enter `1'	material = liquids
	P003	enter `2'	measurement response = 1 m / min
			Note: the associated preset fail-safe timer is 10 minutes. Override this value by setting P070.
	P004	enter `102'	the transducer model purchased with this system is an XPS-10
	P005	enter `1'	units = metres
	P006	enter `3.6'	empty distance = 3.6 m
	P007	enter `3'	span = 3 m
	P070	enter `.1'	fail-safe timer = 6 sec (0.1 min)
	P111-1	enter `3'	relay 1 function = 3, pump sequencing
	P111-2	enter `3'	relay 2 function = 3, pump sequencing
	P112-1	enter `2'	relay 1, on setpoint = 2 m
	P112-2	enter `1'	relay 2, on setpoint = 1 m
	P113-1	enter `.25'	relay 1, off setpoint = 0.25 m (nominal value, 0.1 m deadband)
	P113-2	enter `.25'	relay 2, off setpoint = 0.25 m (nominal value, 0.1 m deadband)
	P802	enter `1'	submergence = on
Run			press run to start normal operation

High Level Switch

The MiniRanger Plus can be programmed as a high level switch. Significant differences between this and other modes of operation are:

- the fail-safe function (P070 and P071) is effectively disabled
- on loss of echo, the measurement immediately defaults to a low value (P006)
- relay setpoints are measured from the face of the transducer
- the reading is distance from the face of the transducer to the material

A high level switch application is primarily used to detect a high level condition. As such, aim the transducer so that it is perpendicular to the material angle of repose at the alarm level when filling.

Example

A high level switch is required in a corn silo when the material comes within 1 m of the transducer face. The maximum filling rate is 0.2 m / min.

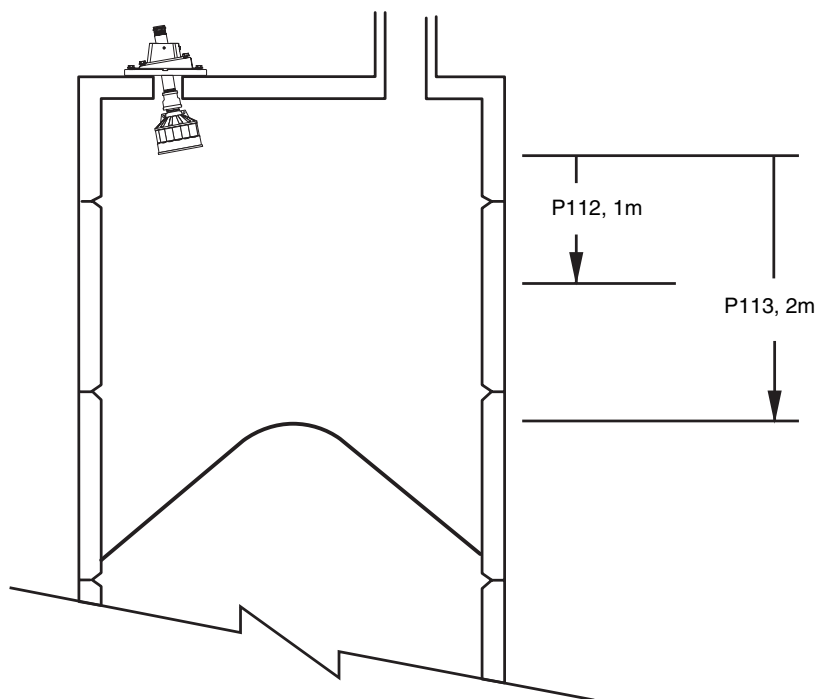

	Parameter	Directions	Description
Reset	P999		master reset
	P001	enter `4'	mode of measurement = high level switch
Program	P002	enter `2'	material = solids
	P003	enter `2'	measurement response = 1 m/min Note: this is the next fastest response rate that would satisfy the given maximum filling rate
	P004	enter `104'	the transducer model purchased with this system is an XPS-15
	P005	enter `1'	units = metres
	P006	enter `4'	empty distance = 4 m (nominal value)
	P007	enter `4'	span = 4 m (nominal value)
	P111-1	enter `1'	level alarm, relay 1
	P112-1	enter `1'	relay 1, on setpoint = 1 m
	P113-1	enter `2'	relay 1, off setpoint = 2 m (nominal value, 1 m deadband)
	Run		

Applications with Standpipe

In many liquid applications, access to the vessel must be made via a standpipe. In such cases, Milltronics can provide optional flanged transducers, or split flanges that mate to a flanged standpipe. Another option is to hang the transducer from a blind flange.

The standpipe length should be as short and the diameter as large as possible. As a rule of thumb, the -3 dB cone of the sound beam should not intersect the standpipe wall in applications opening into a vessel. Otherwise, additional near blanking (P800) is required to compensate for the interference zone created by the opening.

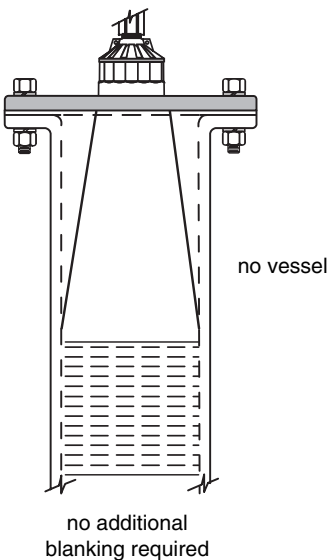
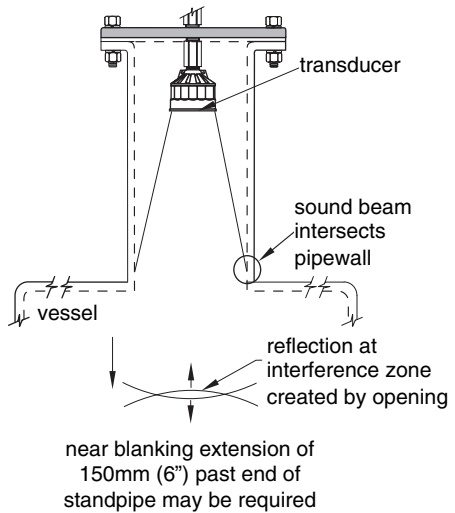
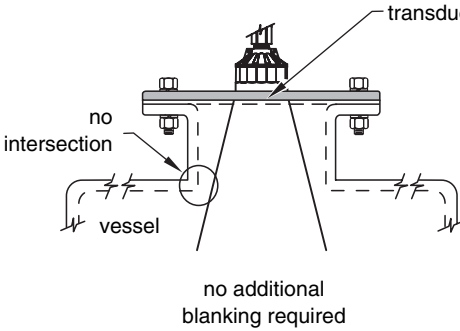

Volume Conversion

Volume conversion can be applied to the measurement, to convert level into volume.

Note:

Volume calculation is an optional feature. MiniRangers with the volume feature have this icon on the front: .

For this example we'll assume the following:

- the vessel is a 3 ft diameter by 15 ft long cylinder (including the parabolic ends of 1.5 ft each).
- the maximum vessel filling rate is 1 ft per minute (slower at mid level).
- a mA output scaled from 4 mA at Full to 20 mA at Empty is required for PLC operation.
- in the event of a measurement difficulty, failsafe operation is to be activated in 6 seconds.
- if the difficulty doesn't subside, the mA output must immediately default to high.
- an XCT-8 transducer is mounted in a standpipe so that the face is 18 in. above the vessel top.

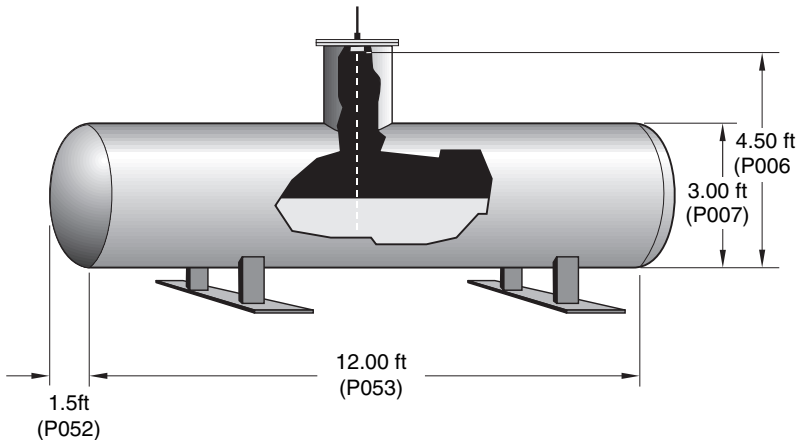

Parameter Settings

Number	Description	Instructions
P001	Operation	Enter "1" for <i>level</i> .
P002	Material	No entry required (preset for <i>liquid</i>).
P003	Measurement Response	Enter "4" for (100 m/min, Failsafe Timer = 0.1 minutes).
P004	Transducer	Enter "101" for <i>XCT-8</i> .
P005	Units	Enter "4" for <i>feet</i> .
P006	Empty	Enter "4.5" for <i>4.50 ft</i> (3 ft diameter plus 1.5 ft in standpipe).
P007	Span	Enter "3" for <i>3 ft</i> (vessel diameter).
P070	Failsafe Timer	No entry required, (preset by P003).
P050	Tank Shape	Enter "7" for <i>horizontal cylinder with parabolic ends</i> .
P051	Max Volume	Enter "117" for <i>117 cubic feet</i> (Use vessel fabricators value).
P052	Tank Dimension A	Enter "1.5" for <i>1.5 ft</i> (the horizontal length of one parabolic end).
P053	Tank Dimension L	Enter "12" for <i>12 ft</i> (the horizontal length, excluding parabolic ends).
P200	mA Range	No entry required. (preset to "2", for 4-20 mA output).

Now in the RUN mode, the Reading Value and mA output will represent volume in cubic feet.

Open Channel Monitoring (OCM)

OCM converts a level reading (head) into a flow value using a linear algorithm. When the MiniRanger is used to calculate flow the mA Output is scaled to the maximum flow (P604) rather than the span (P007).

Note:

OCM calculation is an optional feature. MiniRangers with the OCM feature have this icon on the front: .

Example Flow Characterization

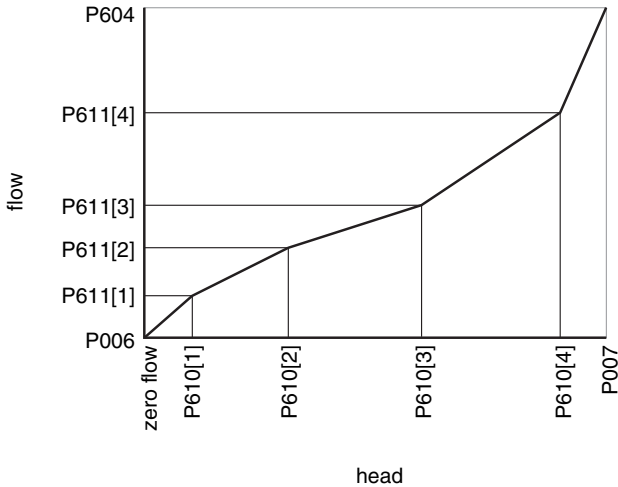

Program these parameters...

- P007 – Span
- P604 – Maximum Flow
- P006 – Empty Distance

...to define the minimum and maximum points on the curve.

Then program the parameters...

- P610[1..9] – Head Breakpoints
- P611[1..9] – Breakpoint Flowrates

...to closely match the flow curve of your primary measuring device (PMD).

Example PMD Programming

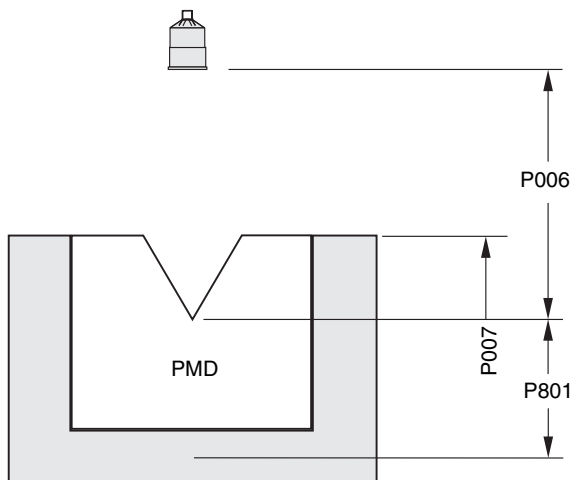

If you do not have the characterization chart for the PMD then you will have to create the chart yourself by measuring the head and flow at multiple points. It is much easier to use the chart supplied by your PMD manufacturer.

All nine programmable breakpoints must be entered in ascending order (lowest to highest) for OCM to work.

Note:

When the MiniRanger is in Program mode no measurements are taken and the current total is reset to zero. This means that the totalizer relay (relay 2) will not trip when the MiniRanger is in Program mode and the external totalizer will read low.

Run the PMD at different head levels and verify the OCM reading given on the MiniRanger to double-check the programming. If this is not possible at least double-check the breakpoints for accuracy.

Parameter Description

P000 Lock

Locks out the programming 'change value' function such that the values of P001 through P999 cannot be changed. This however does not prevent the 'select' function from use for viewing values. Programming is locked out if the value of P000 is other than 1954.

entry:

- = 1954: unlocked
- ≠ 1954: locked

P001 Operation

Determines the mode of measurement.

entry:

- 1 = level; material level referenced to empty distance (P006)
- 2 = space; space to material level referenced from zero span
- 3 = distance; distance to target referenced from the transducer face
- 4 = high level switch (h.l.s.)

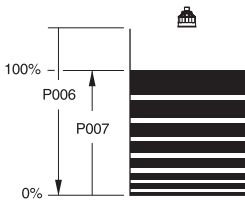

Level (P001 = 1)

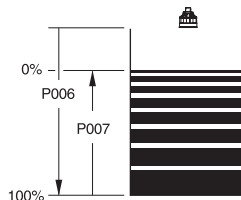

Space (P001 = 2)

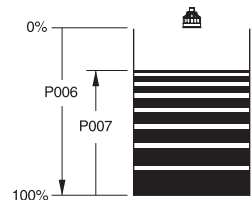

Distance (P001 = 3)
or
H.L.S. (P001 = 4)

P002 Material

Optimizes measurement reliability for target type.

entry :

- 1 = liquids, fluids or flat surfaces
- 2 = irregular surfaces and solids

P003 Measurement Response

Collectively sets a number of operating parameters that determine the maximum rate of change in target range that the reading, alarm and mA output functions can keep up to.

If MiniRanger Plus cannot keep up with the rate of level change, select a faster rate. If the reading bounces around an average value, select a slower rate. In general, reliability is traded for speed. Noisy applications or those with agitators tend to be more reliable at a slower response rate, as they make use of filtering, echo verification and longer fail-safe delay.

Note:

Select P003 for a measurement response just faster than the greater of the maximum filling or emptying rate.

- echo verification: discriminates between agitator blades in motion or spurious noise, and the target surface (true echo).
- filter: discriminates between false echoes from constant acoustical or electrical noise, and the target surface.
- fail-safe timer: establishes the period from the time a loss of echo starts until the fail-safe default (P071) is effected. The P003 preset timer value can be overridden by P070.
- long pulses: sets the number of long pulses to be fired during the course of a measurement. Reliability (2) is traded for speed (1).

entry:

measurement response		echo verification	filter	f-s timer* (P070)	long pulses
1 = 0.1 m/min	(slow)	on	on	100	2
2 = 1 m/min	▪	on	on	10	2
3 = 10 m/min	▪	on	on	1	2
4 = 102 m/min / 1.7 m/sec	▪	off	on	0.1	1
5 = 1020 m/min / 17 m/sec	(fast)	off	off	0	1

* fail-safe function is disabled for high level switch operation, P001 = 4.

P004 Transducer

Identifies transducer model connected (0 is Default after RESET - same as ST-25).

entry :

- 1 = ST-25
- 2 = ST-50
- 100 = ST-H
- 101 = XCT-8
- 102 = XPS-10
- 103 = XCT-12
- 104 = XPS-15
- 111 = XKS-6
- 112 = XRS-5

P005 Units

Determines the units for programming and measurement.

entry :

- 1 = metres
- 2 = centimetres
- 3 = millimetres
- 4 = feet
- 5 = inches

P006 Empty

Distance from transducer face to empty level or maximum target range.

P007 Span

Distance from empty (P006) to full / 100% level or minimum target range.

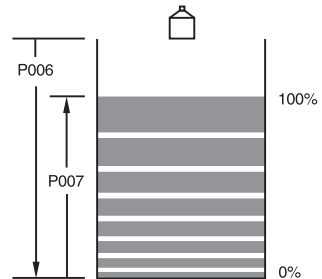

P050 Tank Shape

This parameter, in conjunction with parameters P051, P052 and P053, enable the MiniRanger Plus to show readings based on reservoir volume (rather than level).

Note:

Volume calculation is an optional feature. MiniRangers with the volume feature have this icon on the front: .

Enter the Tank Shape value that matches the monitored vessel or reservoir.

When Operation is "level" (P001 = 1), liquid (material) volume is calculated.

In the RUN mode, Readings are displayed in volumetric units, see Max Volume (P051). When percent is selected, the displayed Reading is the calculated volume as a percentage of Max Volume.

entry:

0 = disabled (Factory)

1 = flat bottom

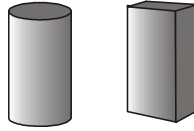

2 = conical or pyramidal bottom

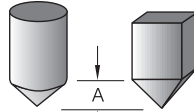

3 = parabolic bottom

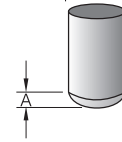

4 = spheric bottom

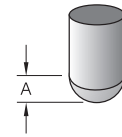

5 = angled bottom

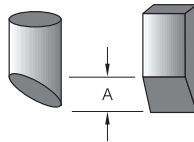

6 = flat ends



7 = parabolic ends

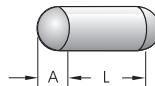

8 = sphere



Tank dimensions 'A' and 'L' are entered via parameters P052 and P053 respectively.

P051 Max Volume

For Readings in volumetric units (rather than percent), enter the vessel volume between Empty (P006) and Span (P007).

The units of measurement for this reading are non-dimensional. The volume is calculated from the empty position to the maximum position and is scaled according to the Tank Shape (P050) value. This enables the use of any volume units required.

Example

If max. volume = 3650 m³, enter 3650.

If max. volume = 267500 gallons, enter 2675 (100's of gallons).

enter the volume of the tank at full (Factory = 1)

Notes:

- Maximum volume entered not to exceed 30,000.
- OCM calculation is an optional feature. MiniRangers with the OCM feature have this icon on the front: .

P052 Tank Dimension 'A'

This is dimension 'A' as used in P050 Tank Shape.

Enter the height of the tank bottom if P050 = 2,3,4, or 5, or the length of one end section of the tank if P050 = 7.

enter the dimension in units (P005)

P053 Tank Dimension 'L'

This is dimension 'L' as used in P050 Tank Shape.

Enter the tank length (excluding both end sections) if P050 = 7.

enter the dimension in units (P005)

P062 Offset Reading

Adds the specified value to the level reading, usually to reference the reading to sea level or another datum level.

The operation of the device is not affected by the Offset Reading. This value is used for display purposes only. All control measurements are still referenced to Empty.

The Offset Reading is ignored when open channel monitoring (OCM, P600 = 1) is used.

Example

To reference the displayed level to sea level, enter the distance in Units (P005), between Empty (P006) and sea level. (Enter a negative value if Empty is below sea level.)

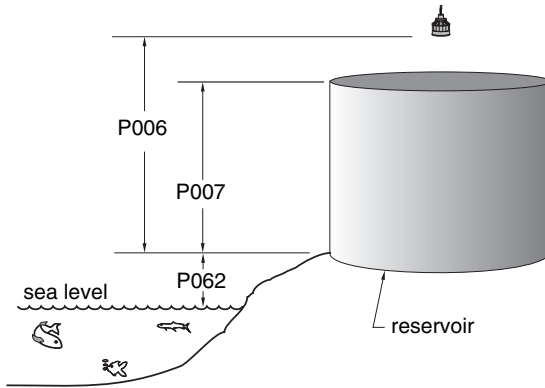

Values

-999 to 9999
Preset: 0.000

P070 Fail-Safe Timer

The amount of time delay, in minutes, before going into fail-safe mode.

Note:

Disabled for h.i.s. operation (P001 = 4)

P071 Fail-Safe Material Level

Selects the default measurement in the event that the fail-safe timer expires.

entry :

- 1 = high; maximum span value
- 2 = low; minimum span value
- 3 = hold; hold current value

Note:

Disabled for h.i.s. operation (P001 = 4)

P111 Relay Function

Assigns an alarm function to the selected relay. Refer to page 36.

entry :

0 = off (default)

1 = alarm on level

2 = control

3 = control with pump sequencing (both relays must be set to 3)

4 = alarm on loss of echo

Note:

OCM calculation is an optional feature. MiniRangers with the OCM feature have this icon on the front: .

P112 Relay A Setpoint

The on setpoint in linear units (P005). Refer to page 36.

P113 Relay B Setpoint

The off setpoint in linear units (P005). Refer to page 36.

P200 mA Range

Enables the mA output function by selecting the range and relationship to span. Refer to mA output on page 40.

entry :

1 = 0 to 20 mA

2 = 4 to 20 mA

3 = 20 to 0 mA

4 = 20 to 4 mA

P300 Temperature, Transducer Max

The maximum temperature encountered by the integral (transducer) temperature sensor.

P341 Run Time

View the accumulated number of days the MiniRanger Plus has been operating.

P600 Primary Measuring Device

The type of primary measuring device (PMD) used for Open Channel Monitoring (OCM).

Note:

OCM calculation is an optional feature. MiniRangers with the OCM feature have this icon on the front: .

This parameter (P600) is not available unless P001 – Operation is set to “1”.

Values

- 0 = off (no OCM calculation) (default)
- 1 = Universal Linear Flow Calculation (see P610, P611)

Note:

When P600=1, then P112 Relay A Setpoint and P113 Relay B Setpoint are not applicable.

P604 Maximum Flow

The maximum flowrate associated with the top of Span (P007).

This value represents the flow at the highest head level supported by the PMD. It works in conjunction with Span (P007) to define the highest point in the curve.

Use this parameter with Time Units (P606) to define the flowrate units.

Values

- 0 to 30,000
- Preset = 1000

P606 Time Units

Defines the time element of the flow units.

e.g. If flowrate is displayed in millions of gallons / day, and the maximum flowrate is 376,500,000 gallons / day, enter “376.5” for Maximum Flow (P604) and “4” for Time Units (P606).

Values

- 1 = seconds
- 2 = minutes
- 3 = hours
- 4 = days (default)

P610 Head Breakpoints

The head breakpoints for which flowrate is known.

These are the values in the Span for which flowrates are known. See Open Channel Monitoring (OCM) on page 53 for a description of how to specify breakpoints.

Values

0.0 to 15.0 meters (or equivalent units as defined by P005)

P611 Breakpoint Flowrates

The flowrate corresponding to each Head Breakpoint entered.

These are the flowrates for the related breakpoints. . See Open Channel Monitoring (OCM) on page 53 for a description of how to specify breakpoints.

Values

0.000 to 30,000

P640 Remote Totalizer Multiplier

Multiplies the number of OCM units needed per relay “click.”

Enter the factor (powers of 10 only) by which actual volume is divided, prior to Remote Totalizer count increment.

e.g. for a Remote Totalizer update by 1000's of volume units, enter 3.

Note:



When the MiniRanger is put into program mode the cumulative total used to trigger the next totalizer relay “click” is reset to 0. This disruption will cause the external totalizer to read lower than the actual OCM total, depending on the number of times programming mode is used and the amount of time spent there.

Values

0 = 1
1 = 10
2 = 100 (default)
3 = 1000
4 = 10,000
5 = 100,000
6 = 1,000,000



P650 Offset Calibration

Typically used to calibrate the ultrasonic measurement, and its associated outputs, to a known value.

- fill the tank as much as permissible, without going into the near blanking.
- monitor P650 until a stable reading is obtained.
- Press  (to access change function).
- scroll the value to the actual level, space or distance respective to the mode of measurement (P001).
- Press  (to validate entry). The MiniRanger Plus calculates the measurement offset to be applied to the reading.

P651 Sound Velocity Calibration

Provides sound velocity compensation on an empty tank. This is typically required on an application where the atmosphere in the tank is a *homogenous gas or vapour* other than air.

- empty the tank as much as permissible. Leave filled with normal vapour and normal operating temperature.
- monitor P651 until a stable reading is obtained.
- Press  (to access change function).
- scroll value to the actual level, space or distance respective to the mode of measurement (P001).
- Press  (to validate entry). The MiniRanger Plus calculates the new sound velocity for measurement correction.

P661 Temp Fixed

For use with ST-25 Ultrason® transducers. As these transducers do not have an integral temperature sensor, a nominal value representing the ambient temperature of the transducer must be entered.

If the temperature between the transducer and the target varies, enter the average temperature.

entry:

-50 to 150 °C

P664 Temperature

View the temperature in °C as registered by the transducer's integral temperature sensor (Echomax series). If a non temperature sensing transducer is being used, the fixed temperature (P661) is displayed.

values:

-50 to 150

Notes

- Not accessible via application device keypad
- Accessible only via Dolphin.

P740 Peripheral Communication

Note:

Applicable to rack and panel units only.

Determines the ASCII message format.

entry:

- 0 = off if communication is not required
- 1 = unformatted messages are transmitted in a continuous string
- 2 = formatted commas are inserted between message fields

The MiniRanger plus Rack and Panel units provide a proprietary 20 mA bipolar current loop for communication with the Milltronics BIC-2 peripheral device.

The MiniRanger Plus uses *simplex convention* communication protocol. Data messages are continuously transmitted at regular intervals (no poll is required) at 4800 baud. All data is transmitted in structured messages of ASCII characters consisting of 8 data bits, no parity, and 1 stop bit.

If Peripheral Communications (P740) is set for "formatted" messages, a comma is inserted between each message field (except immediately preceding the "End of Message" characters).

MT-00 Measurement Message

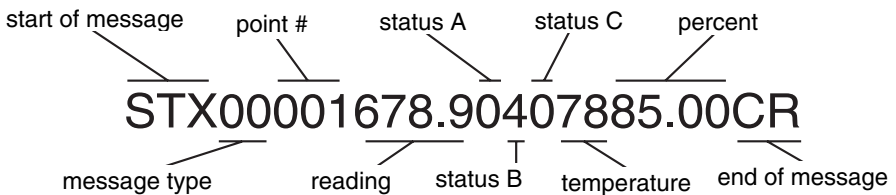

Field Name	Definition
Start Of Message	STX (\$02)
Message Type	2 characters, 00 (indicates the following data pertains to a scan point measurement)
Point #	3 characters, 001 (e.g. the message pertains to Point Number 1)
Reading	5 characters, 0.000 to 9999. (e.g. reading = 678.9, DDDD. = no data, EEEE. = overflow)

MT-01 Hold Message

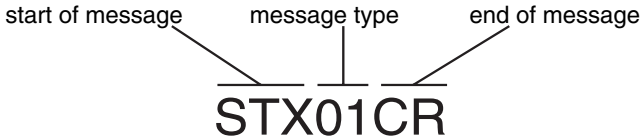

Field Name	Definition
Start Of Message	STX (\$02)
Message Type	2 characters, 01 (indicates the MiniRanger was removed from the RUN mode)
End Of Message	CR (\$0D)

P800 Near Blanking

Sets the amount of blanking as measured from the transducer face and extending into the measurement range. Refer to Blanking on page 34.

enter value referenced from the face of the transducer in units of P005.

P801 Range Extension

Sets the amount of range extension as measured from the empty distance (P006) and extending into the far end blanking. Refer to Blanking on page 34.

enter as a % of P006, the distance below empty not blanked.

P802 Submergence Transducer

When using a submergence transducer, set entry to `1' to enable submergence feature. Refer to Pump Control Application on page 46.

entry:

0 = normal

1 = submersible

P804 Confidence Threshold

The minimum echo confidence in dB that either the short or long echo must meet in order to prevent a loss of echo condition and the expiration of the fail-safe timer (P070).

short minimum echo confidence for short pulse echoes; those within the short pulse echo range.

long minimum echo confidence for long pulse echoes.

entry:

: ## = short : long

P805 Echo Confidence

A measure of echo reliability.

display:

: ## = short : long

where:

= 0 to 99 ; confidence value

P806 Echo Strength

The absolute strength of the selected echo, in dB above 1 uV rms.

P807 Noise

The peak and average ambient noise, in dB above 1 uV rms.

Ambient noise includes acoustical and electrical noise being picked up by the transducer / receiver circuit while in the program mode (transmit disabled).

display:

: ## = average : peak

P820 Algorithm

Selects the algorithm to be applied to the echo profile in order to extract the true echo.

entry:

1 = best of first and largest

2 = first echo

3 = largest echo

P825 Echo Marker Trigger

Specifies the point on the primary echo on which the measured value is based.

Use this feature if the reported material level fluctuates slightly, due to a variable rise in the leading edge of the true echo on the Echo Profile.

Enter the value (in percent of echo height) to ensure the Echo Lock Window intersects the Echo Profile at the sharpest rising portion of the Echo Profile representing the true echo. This value is preset to 50%.

Values

5 to 95%

P830 TVT Type

Selects the TVT profile applied to the echo profile.

entry:

1 = standard

2 = flat (typically; may yield higher confidences on some solids applications)

P900 Software Revision

Displays the EPROM software revision level.

P901 Memory

Tests the memory. Test is initiated by scrolling to the parameter or repeated by pressing. 

display:

PASS = normal

FAIL = consult Milltronics

P907 Programmer Interface

Tests the infrared communication link. Test is initiated by scrolling to the parameter or repeated by pressing. 

display:

PASS = normal

FAIL = consult Milltronics

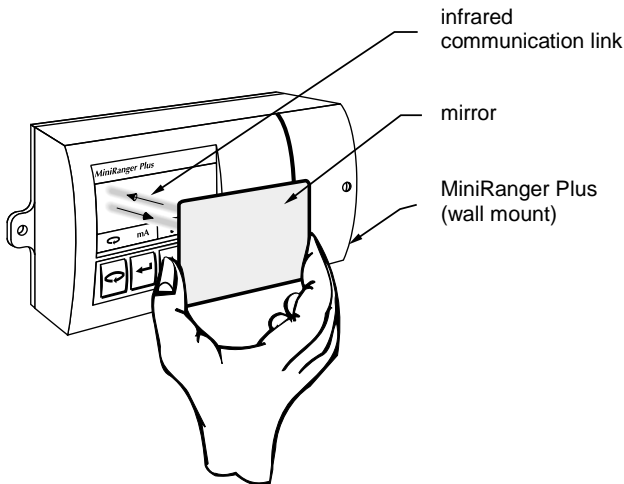

Note:

Not applicable to rack and panel mount units.

P910 Relay

Tests the alarm relays.

entry:

0 = de-energizes selected relay

1 = energizes selected relay

P911 mA Output Value

Displays the value from the previous measurement. A test value can be entered and the displayed value is transmitted to the output. Upon returning to the run mode, the parameter assumes the actual mA output level.

P920 Reading Measurement

The reading as viewed in the run mode.

Note:

Not accessible via application device keypad

P999 Master Reset

Resets parameters to their factory setting.



Press 



Troubleshooting

The following is a list of operating symptoms, their probable causes and the actions needed to resolve them.

Symptom	Cause	Action
Loss of echo display reads 'Short', no pulsing is felt on the transducer face	connection of a transducer without a built-in temperature sensor (ST 25C) short circuit or reverse wiring defective transducer	check transducer type and correct P004 if required. check transducer wiring* check maximum temperature P300 against transducer rating* try substitute.
display reads 'OPEN', no pulsing is felt on the transducer face	open circuit defective transducer or circuit board	check transducer wiring* check maximum temperature P300 against transducer rating* try substitute.
display reads,  pulsing is felt on transducer face.	level or target is out of range application too dusty or steamy, under these conditions, range can be adversely affected. material build up on transducer face	check transducer specifications* check calibration parameters re-aim transducer* use foam faced transducer for dusty applications*. try using a longer range transducer. increase fail-safe timer, P070 clean move transducer to a better location mount in standpipe

*refer to associated transducer manual.

Troubleshooting

Symptom	Cause	Action
... continued	<p>transducer location for aiming: poor installation moved my material or vibration flanging not level</p> <p>transducer malfunction: temperature too high physical damage excessive foam on liquid face</p>	<p>relocate or re-aim transducer for maximum echo confidence, P805</p> <p>check P300, P805, p807</p> <p>inspect</p> <p>use foam deflector or stilling well or relocate,</p>
Reading does not change, but the level does	<p>MiniRanger Plus processing wrong echo, i.e. vessel wall, structural member, stationary agitator, material hang-up or rat-hole.</p> <p>transducer ringdown, reading high level</p>	<p>re-aim transducer*</p> <p>check standpipe for internal burrs or welds</p> <p>mounting need only be hand tight*</p> <p>increase blanking, P800</p> <p>raise short measurement confidence threshold, P804</p>
Measurement is consistently off by a constant amount	measurement offset	refer to P650
Reading error progressively worsens with distance	atmosphere other than air or stratified	refer to P651
Screen blank	loss of power	check power wiring

*refer to associated transducer manual.

Symptom	Cause	Action
Reading erratic	echo confidence weak, liquid surface agitated, material filling electrical noise agitator blades	refer to P805, P807 decrease measurement response P003 enable filter, echo verification relocate transducer* check P807 under quiescent conditions, noise should be 15 dB transducer cable must be in grounded metal conduit and cable grounded only at TB-1* enable echo verification, P003
Reading 'EEEE'	reading too large	re-calibrate
Reading response slow	P003 setting	increase response if possible
Reads correctly, but occasionally reads high when vessel is not full	detecting close range echo or ringdown	increase blanking increase shot measurement threshold, P804 transducer mounting*
High level reading lower than material level	material is within near blanking zone echo multiple being processed	decrease blanking P800 (limit to transducer min range*) or raise transducer

*refer to associated transducer manual.

Maintenance

The MiniRanger Plus. requires no maintenance, however a program of periodic checks is advised.

If the MiniRanger Plus wall unit is mounted in a dusty or oily environment, make sure that the programmer, optional Dolphin ComVerter, and front cover are kept clean; otherwise it may impede the infrared signal transmission.

Appendices

Alphabetical Parameter List

algorithm	P820	range extension	P801
breakpoint flowrates	P611	relay	P910
confidence threshold	P804	relay A setpoint	P112
echo confidence	P805	relay B setpoint	P113
echo marker trigger	P825	relay function	P111
echo strength	P806	remote totalizer multiplier	P640
empty	P006	run time	P341
fail-safe material level	P071	software revision	P900
fail-safe timer	P070	sound velocity calibration	P651
head breakpoints	P610	span	P007
lock	P000	submergence transducer	P802
mA output value	P911	tank shape	P050
mA range	P200	tank shape 'A'	P052
master reset	P999	tank shape 'L'	P053
material	P002	temperature, fixed	P661
max volume	P051	temperature, transducer max	P300
maximum flow	P604	time units	P606
measurement response	P003	transducer	P004
memory	P901	TVT type	P830
near blanking	P800	units	P005
noise	P807		
offset calibration	P650		
offset reading	P062		
operation	P001		
peripheral communication ²	P740		
primary measuring device	P600		
programmer interface ³	P907		

² not applicable to wall mount units

³ not applicable to rack and panel units

Programming Chart

Parameter		
#	Name	Value
P001	Operation	
P002	Material	
P003	Measurement Response	
P004	Transducer	
P005	units	
P006	Empty	
P007	Span	
P050	Tank Shape	
P051	Max Volume	
P052	Tank Shape 'A'	
P053	Tank Shape 'L'	
P062	Offset Reading	
P070	Fail-Safe Timer	
P071	Fail-Safe Material	
P111[1]	Relay Function	
P111[2]	Relay Function	
P112[1]	Relay A Setpoint	
P112[2]	Relay A Setpoint	
P113[1]	Relay B Setpoint	
P113[2]	Relay B Setpoint	
P200	mA Range	
P300	Temperature, Transducer Max	
P341	Run Time	
P600	Primary Measuring Device	
P604	Maximum Flow	
P606	Time Units	
P610	Head Breakpoints	
P611	Breakpoint Flowrates	
P640	Remote Totalizer Multiplier	
P650	Offset Calibration	
P651	Sound Velocity Calibration	
P661	Temperature, Fixed	
P740	Peripheral Communication*	
P800	Near Blanking	
P801	Range Extension	
P802	Submergence Transducer	
P804	Confidence Threshold	
P820	Algorithm	
P825	Echo Marker Trigger	
P830	TVT Type	

* rack and panel mounts only

www.milltronics.com

MILLTRONICS

Siemens Milltronics Process Instruments Inc.
1954 Technology Drive, P.O. Box 4225
Peterborough, ON, Canada K9J 7B1
Tel: (705) 745-2431 Fax: (705) 741-0466
www.milltronics.com

© Siemens Milltronics Process Instruments Inc. 2001
Subject to change without prior notice.



Printed in Canada