

MILLTRONICS

**POINTEK CLS 100
CAPACITANCE • LIQUIDS/SOLIDS**

Instruction Manual

March 2001

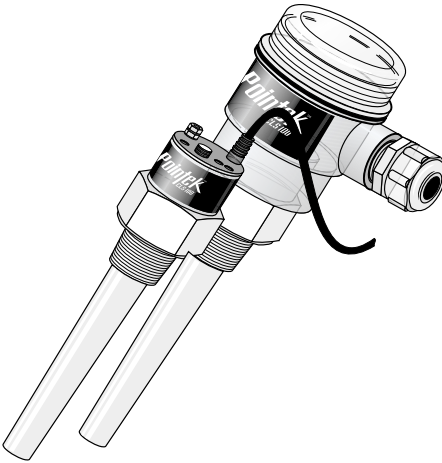

POINTEK CLS 100

Safety Guidelines

Warning notices must be observed to ensure personal safety as well as that of others, and to protect the product and the connected equipment. These warning notices are accompanied by a clarification of the level of caution to be observed.

Qualified Personnel

This device/system may only be set up and operated in conjunction with this manual. Qualified personnel are only authorized to install and operate this equipment in accordance with established safety practices and standards.

Warning: This product can only function properly and safely if it is correctly transported, stored, installed, set up, operated, and maintained.

Note: Always use product in accordance with specifications.

Copyright Siemens Milltronics Process Instruments Inc. 2000. All Rights Reserved

Disclaimer of Liability

This document is available in bound version and in electronic version. We encourage users to purchase authorized bound manuals, or to view electronic versions as designed and authored by Siemens Milltronics Process Instruments Inc. Siemens Milltronics Process Instruments Inc. will not be responsible for the contents of partial or whole reproductions of either bound or electronic versions.

While we have verified the contents of this manual for agreement with the instrumentation described, variations remain possible. Thus we cannot guarantee full agreement. The contents of this manual are regularly reviewed and corrections are included in subsequent editions. We welcome all suggestions for improvement.

Technical data subject to change.

MILLTRONICS® is a registered trademark of Siemens Milltronics Process Instruments Inc.

Contact SMPI Technical Publications at the following address:

Technical Publications
Siemens Milltronics Process Instruments Inc.
1954 Technology Drive, P.O. Box 4225
Peterborough, Ontario, Canada, K9J 7B1
Email: techpubs@milltronics.com

For the library of SMPI instruction manuals, visit our Web site: www.milltronics.com

Table of Contents

Introduction to the Pointek CLS 100	2
Pointek CLS 100 Features	2
Pointek CLS 100 Applications	2
Specifications	3
Installation	5
Location	5
Outline and Dimension	6
Cable Version	6
Enclosure Version	7
Mounting	8
Installation Features and Restrictions	8
Process Cautions	10
Connections	11
Cable Version	11
Enclosure Version	11
Alarm Output Status	12
Definitions	12
Power / Alarm Wiring	13
Solid State Switch Application	14
Connection Diagram – Hazardous Location	15
Connection Drawing – Non-Hazardous Location	16
Operation	17
Setup	17
Start Up	17
Alarm Output	18
Troubleshooting	20
Maintenance	20
Appendix: Approvals	21
Index	22

Introduction to the Pointek CLS 100

Note: Pointek CLS 100 is to be used only in the manner outlined in this instruction manual.

The Pointek CLS 100 capacitance level switch provides 4 or 20 mA output and solid state switch contact for detection of high and low process material levels. When the measured material approaches or contacts the switch's probe, an increase in capacitance is sensed and a high level alarm can be triggered. If a low level alarm is required then the lack of material contact is sensed and this condition triggers the low level alarm.

Pointek CLS 100 Features

- NPT, BSPT process connections
- Corrosion resistant construction, Kynar® and 316 stainless steel wetted parts
- Non-polarized, solid-state switch
- 4 or 20, and 20 or 4 mA loop alarm output

Pointek CLS 100 Applications

- Liquids, slurries, powders, granules, and solids
- Foods and pharmaceuticals
- Chemical and petrochemical
- Relatively high pressure and temperature
- Hazardous areas

Specifications

Electrical/Instrument

Power

standard:	10 – 33V dc
intrinsically safe:	10 – 30V dc

Alarm Output:

mA:	4/20 mA loop or 20/4 mA 2-wire loop
solid state switch:	standard: <ul style="list-style-type: none">• 40 Vdc / 28 Vac• 100 mA max• 2 VA max intrinsically safe: <ul style="list-style-type: none">• 30V dc
repeatability:	2mm (0.08")
mode:	high or low

Mechanical

common:	probe / wetted, 316 stainless steel process connection and Kynar ^{®1} sensor
cable version:	<ul style="list-style-type: none">• body / housing, 316 stainless steel• process connection, 3/4" NPT or 1" BSPT• 1m (3.3 ft) of 4 conductor, 22 AWG, shielded, polyester jacket
enclosure version:	<ul style="list-style-type: none">• body: impact proof ABS• lid: translucent ABS• internal 5-point terminal block• ½" NPT wiring entrance (PG 13 on special order)

Environmental

location:	indoor/outdoor
altitude:	2000m max
ambient temperature:	-40 to 85 °C (-40 to 185 °F)
ingress protection:	Type 4X / NEMA 4X / IP65
installation category:	II
pollution degree:	4

Process

dielectric constant (ϵ_r):	1.5 min
temperature	-40 to 110 °C (-40 to 230 °F)
pressure (vessel)	0 absolute to 1000 kPa (10 bar or 146 psi) gauge, nominal

¹® Kynar is a registered trade mark of ELF Atochem

Approvals

cable version:

- CSA
- CENELEC
- FM
- KEMA

enclosure version:

- CSA
- CENELEC
- FM
- KEMA

Installation

Location

Notes

- Installation shall only be performed by qualified personnel and in accordance with local governing regulations.
- This product is susceptible to electrostatic shock. Follow proper grounding procedures.

The Pointek CLS 100 is normally mounted into the vessel top (high detection alarm) or through the tank wall at the detection level (high or low detection alarm).

Horizontal

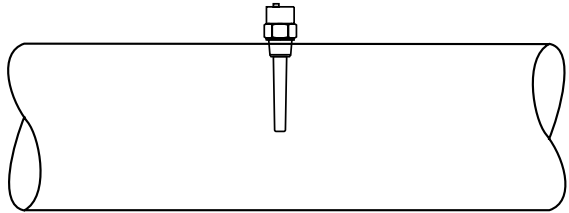

Angle

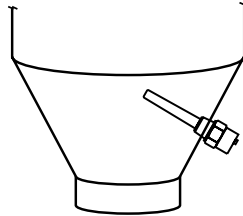

Vertical

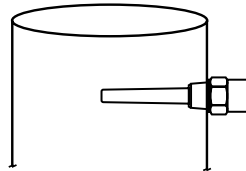

Outline and Dimension

Cable Version

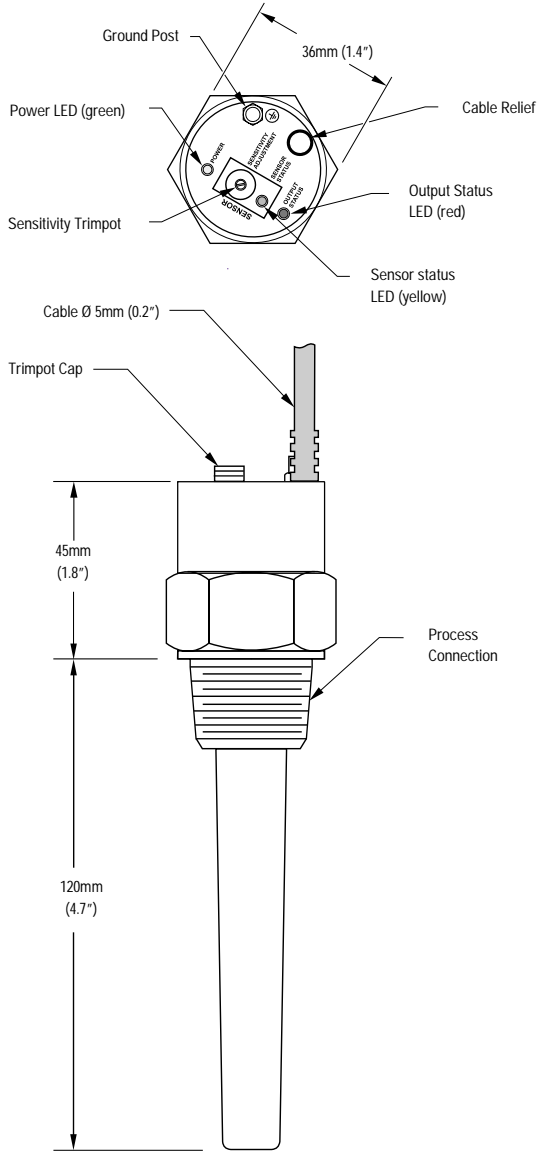

Enclosure Version

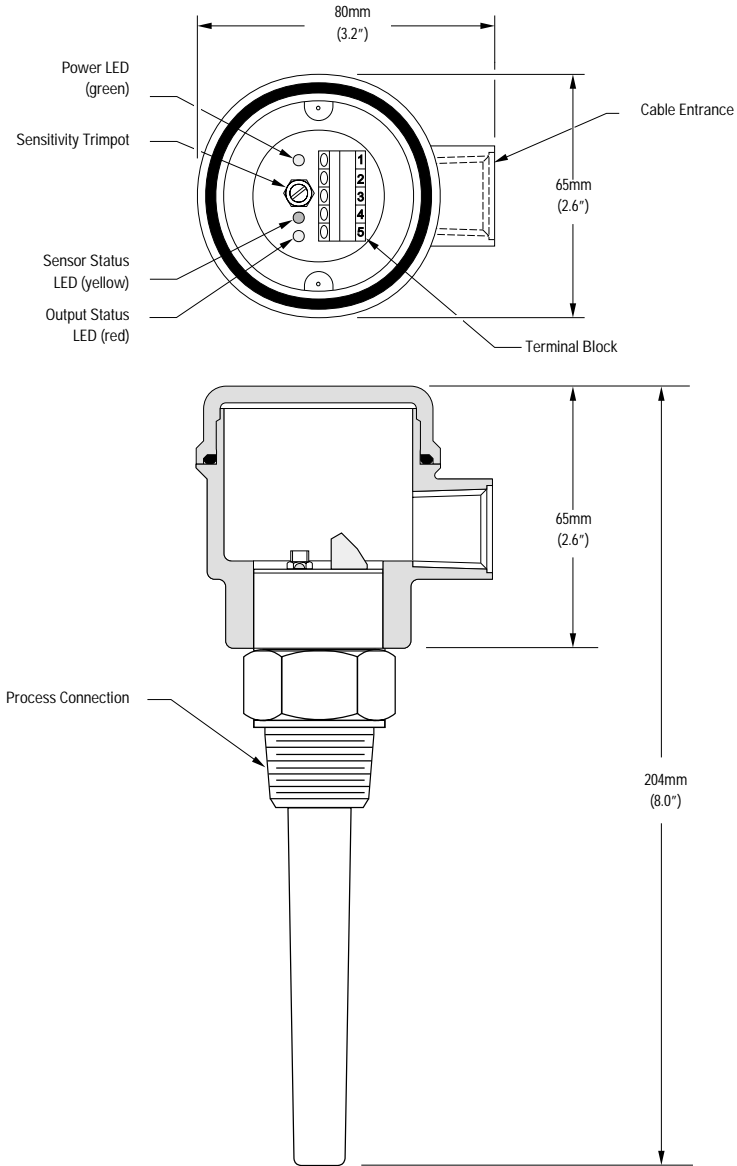

Label Colors

Color	Description
green	dust ignition proof
black	general purpose
blue	intrinsically safe

Mounting

Installation Features and Restrictions

Please note the following installation features and restrictions to ensure that your unit operates properly.

Note: All sample mounting diagrams show the Cable version but apply to the Enclosure version also.

Standpipes

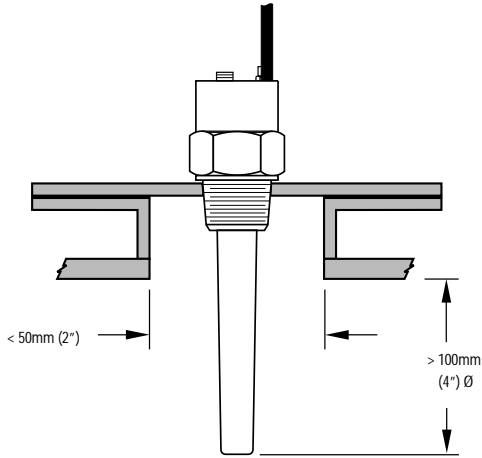

Multiple Units

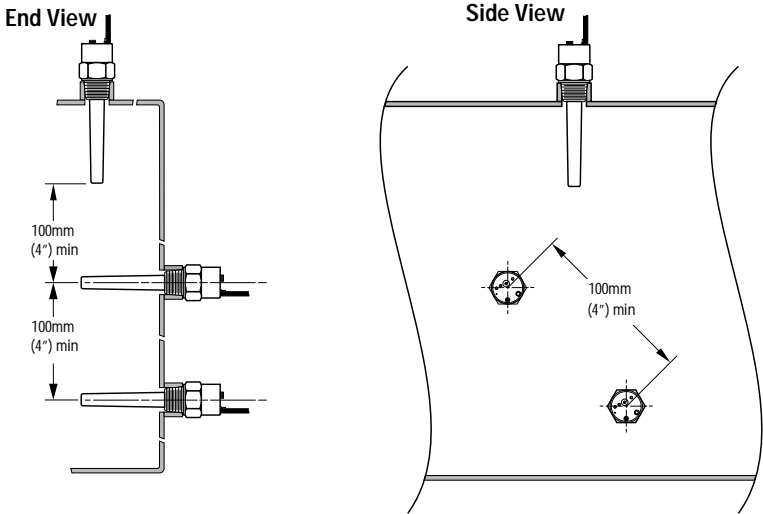

Sensors must be 100mm apart.

Mount diagonally if vertical space is restricted.

Wall Restriction

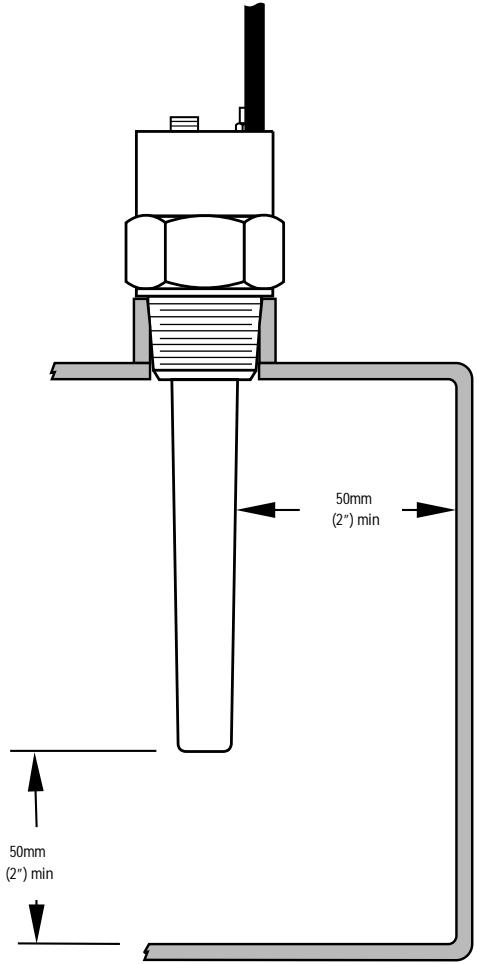

Process Cautions

Caution: Keep out of path of falling material.

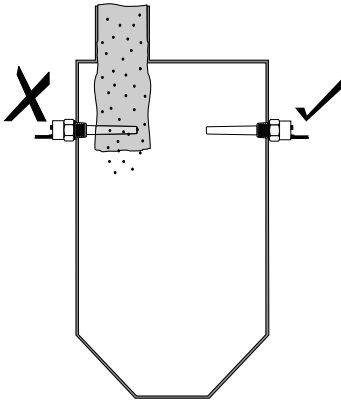

Caution: Consider material surface configuration when installing unit.

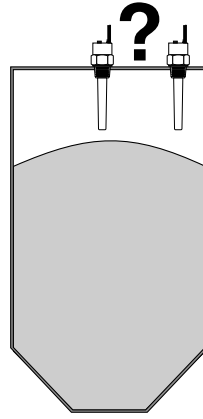

Caution: protect probe from falling material.

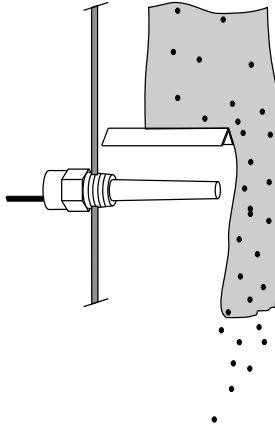

Caution: avoid areas where material build up occurs.

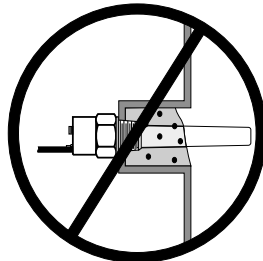
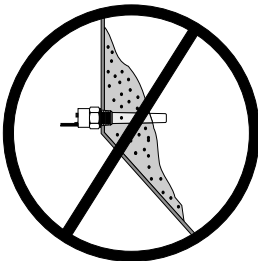

Connections

Cable Version

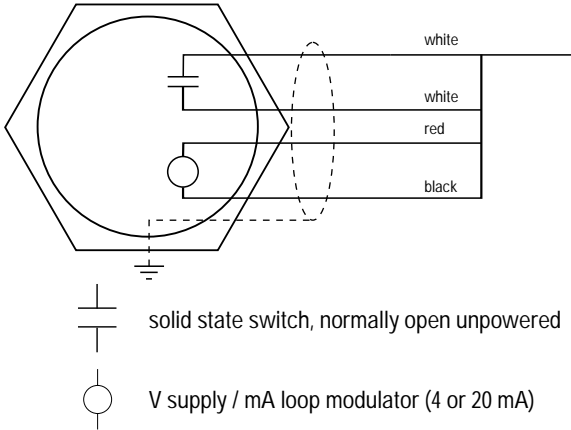

Enclosure Version

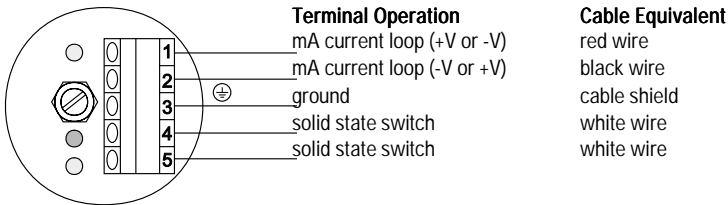

Note: The mA current loop can be wired in either polarity to determine high or low level operation as shown in the examples starting on page 13.

Alarm Output Status

Alarm Status	Covered Yellow LED ON	Uncovered Yellow LED OFF	Power Connection
High (fail safe)	Red LED OFF 4mA SSS* = open	Red LED ON 20mA SSS = closed	Black wire + V
High (non fail safe)	Red LED ON 20mA SSS = closed	Red LED OFF 4mA SSS = open	Red wire + V
Low (fail safe)	Red LED ON 20mA SSS = closed	Red LED OFF 4mA SSS = open	Red wire + V
Low (non fail safe)	Red LED OFF 4mA SSS = open	Red LED ON 20mA SSS = closed	Black wire + V

Note: *SSS is the solid state switch

Definitions

Alarm Conditions as defined below can be detected in a fail-safe or non fail-safe mode.

Fail Safe

- The sensor connection arrangement of the CLS 100 is fail-safe if the output status is in alarm status when power fails, which is an open contact state.
- The sensor connection arrangement of the CLS 100 switches to the alarm status when power fails, which is an open contact state.

High Alarm

- Condition in which the material has reached a maximum level for the process (probe covered).

Low Alarm

- Condition in which the material has reached a minimum level for the process (probe uncovered).

Power / Alarm Wiring

Note: For terminal block equivalents see Enclosure Version on page 11.

Standard Version - Non Intrinsically Safe

LOW Alarm

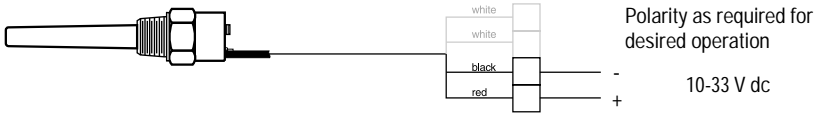

HIGH Alarm

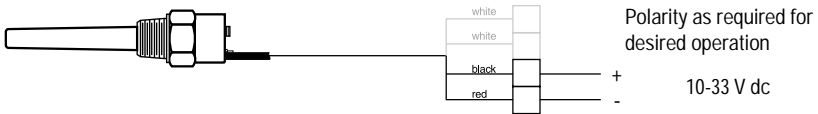

4 / 20 mA Loop Alarm

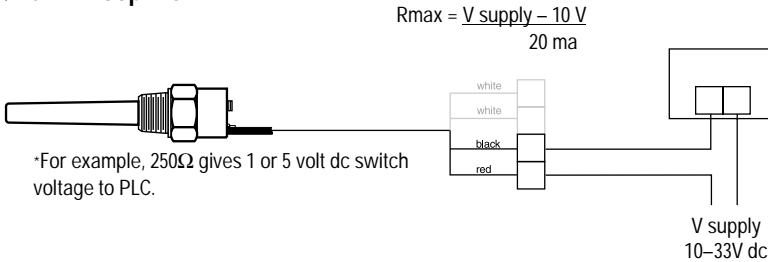

Solid State Switch Application

Standard Version - Non Intrinsically Safe

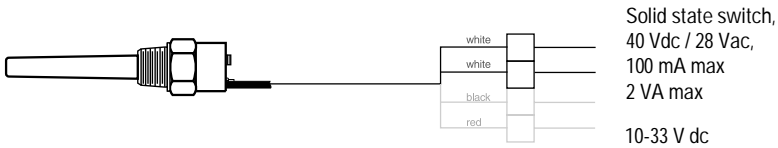

Protection Diodes

Always use a protection diode when driving an external relay with the solid state switch. This prevents possible switch damage due to inductive spikes generated by the relay coil.

Orient the diode based on the current flow.

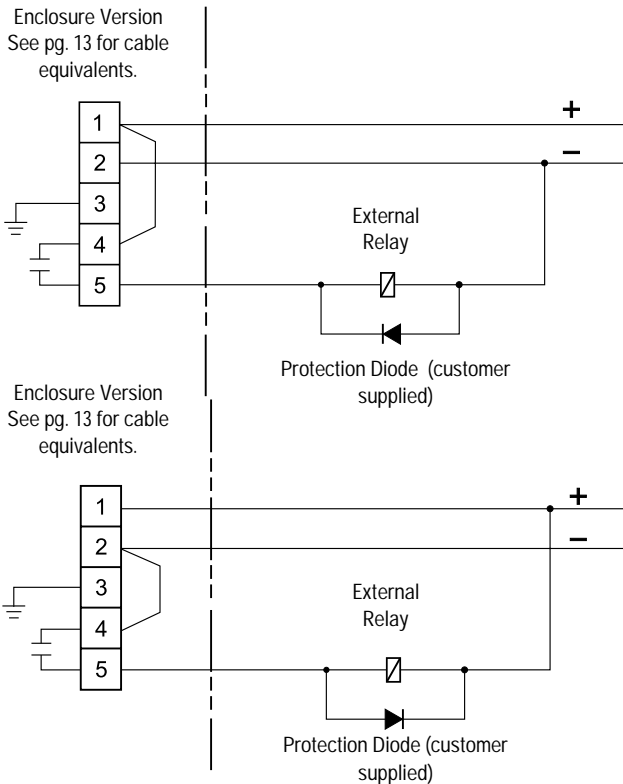

Operation

Unscrew the clip to access the terminals.

Setup

Note: Setup can be done in the field with the Pointek CLS mounted into process, or in the shop prior to mounting.

Start Up

After the CLS is properly mounted and wired, apply power to the unit. The green LED lights to indicate the unit is powered and operational.

Indicators

Three LEDs indicate the following:

Yellow = sensor status:

When the trim pot is properly set, this LED indicates when the sensor is in contact with the process material (material capacitance is greater than the setpoint).

This LED is off when the sensor is out of contact with the process material (material capacitance is less than the setpoint).

Red = output status:

This LED indicates the mA loop alarm and solid state switch contact status. Refer to Alarm Output Status on page 12.

Green = power:

This LED is on when the Pointek CLS is properly powered.

Alarm Output

Setpoint Adjustment

As a reference, and to assist in adjusting the alarm setpoint for reliable and accurate detection of the process material, we have classified the materials and applications into three cases.

Follow the setup procedure associated to the case outline describing your application.

Case 1

General applications, characterized by the following:

- dry solids
- low viscosity liquids

Case 2

Demanding applications, characterized by the following:

- hygroscopic / wet solids
- high viscosity and high conductivity liquids

Case 3

Interface detection:

- e.g. liquid A / liquid B, foam / liquid

Trim Pot Placement

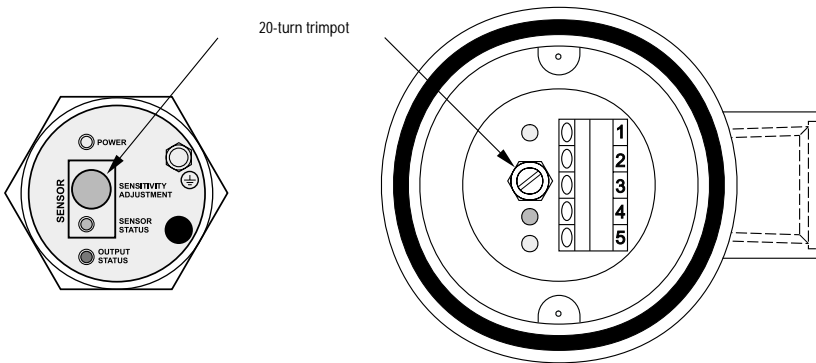

Case 1

Preparation

- Ensure that the green LED is **ON**.
 - If yellow LED is **ON**, turn the trimpot CCW (counter clockwise) until the yellow LED goes **OFF**, otherwise go to step 1 below.
1. With sensor uncovered and a minimum 100 mm free space all around, turn the trimpot CW (clockwise) until the yellow LED just goes **ON**.
 2. Turn the trimpot CCW until the yellow LED just goes **OFF**.

Case 2

Preparation

- Ensure that the green LED is **ON**.
- Turn the trimpot CCW (counter clockwise), until the yellow LED just goes **OFF**.

Configuration

1. Adjust the material level of the process so that the sensor is immersed, the yellow LED should be **ON**.
2. Adjust the material level of the process so that the sensor is uncovered, but retains significant (as much as possible) build up of material on the sensor.
3. Adjust the trimpot CCW until yellow LED goes **OFF**. To get the true feel for the correct position, please adjust the trimpot CW then CCW several times to ensure that the yellow LED is **OFF**. (This adjustment is very sensitive, and we recommend this practice exercise so you can fine tune the trimpot movement until the yellow LED L1 turns **OFF** with minimal adjustment.)

Case 3

Preparation

- Ensure that the green LED is **ON**.
- Turn the trimpot CCW (counter clockwise), until the yellow LED just goes **OFF**.

Configuration

1. Immerse the sensor in the material that has the lowest dielectric constant. The yellow LED should be **ON**.
2. Adjust the trimpot CCW until the yellow LED goes **OFF**.
3. Immerse the sensor in the material that has the highest dielectric constant; the yellow LED should come **ON**.

Note: After completing the setup, replace the trimpot cap. The unit is now in service, providing level detection of your process.

Troubleshooting

Symptom	Observation	Action
No switching action when sensor covered / uncovered	Green LED OFF	Check power connections and voltage
	Green LED ON yellow LED continuously ON	Reduce the sensitivity by turning the trimpot CCW
	Green LED ON yellow LED continuously OFF	Increase the sensitivity by turning the trimpot CW
No switching action when sensor covered / uncovered. Previous checks not effective	Green LED is ON Yellow LED doesn't change state as in 2 and 3 above.	Possible failed sensor – check with supplier

Maintenance



The Pointek CLS requires no maintenance or cleaning.

Appendix: Approvals

WRITTEN DECLARATION OF CONFORMITY

We, Siemens Milltronics Process Instruments B.V.
Nikkelstraat 10 - 4823 AB BREDA - The Netherlands

Declare, solely under own responsibility, that the product
Point Level Switch, Pointek CLS 100
Mentioned in this declaration, complies with the following standards and/or normative documents:

Requirements	Remarks	Certificate No
EMC Directive 89/336/EEC	Commercial, light Industrial, and industrial	71103-KRO/EMC 97-4905
EN 55011: 1991	Emission – Class B	
EN 50082-2: 1995 EN 61000-4-2: 1995 EN 61000-4-3: 1996 ENV 50204: 1995 EN 61000-4-4: 1995 EN 61000-4-5: 1995 EN 61000-4-6: 1996	Generic Immunity Standard, from which: Electrostatic Discharge (ESD) Immunity Radiated Electro-Magnetic Field Immunity Digital Radio Telephones Immunity Electrostatic Fast Transient (EFT) Immunity Surge Transient Immunity Conducted Radio-Frequency Disturbances Immunity	
ATEX Directive 94/9/EC	Audit Report No 2003068	KEMA 00ATEXQ3047
	 II 1/ 2 GD EEx d [ia] IIC T6...T4  0344	KEMA 00ATEX1038X
	T 100 °C IP 66	
EN 50014: 1992 EN 50020: 1994 EN 50284: 1999 EN 50281-1-1: 1998	General Requirements Intrinsic Safety "i" Special Requirements for Category 1G Equipment Dust Ignition Proof	

The notified body is: N.V. KEMA – Utrechtseweg 310 – 6812 AR Arnhem – The Netherlands

Location: Breda **Representative Name:** C.S. van Gils
Date: October 1st, 2000 **Function:** Managing Director

Remark:
For specific safety specifications, please consult the instrument label.

Index

A

Alarm Output	20
Alarm Output Status	14
Alarm Output:	5
Angle	7
Applications	4
Approvals	6, 23

C

Cable Version	8, 13
Connection Diagram – Hazardous Location ..	17
Connection Drawing – Non-Hazardous Location	18
Connections	13

D

Definitions	14
-------------------	----

E

Electrical/Instrument	5
Enclosure Version	9, 13
Environmental	5

F

Fail Safe	14
falling material	12
Features	4

H

High Alarm	14
Horizontal	7

I

Indicators	19
inductive spikes	16
Installation Features and Restrictions	10
Introduction	4

L

Label Colors	9
--------------------	---

Location	7
Low Alarm	14

M

Maintenance	22
material surface configuration	12
maximum level	14
Mechanical	5
minimum level	14
Mounting	10
Multiple Units	10

O

Operation	19
-----------------	----

P

Power	5
Power / Alarm Wiring	15
Process Cautions	12
Protection Diodes	16

S

Setpoint Adjustment	20
Setup	19
Solid State Switch Application	16
Standard Version - Non Intrinsically Safe	15, 16
Standpipes	10
Start Up	19

T

Trim Pot Placement	20
Troubleshooting	22

V

Vertical	7
----------------	---

W

Wall Restriction	11
------------------------	----

www.milltronics.com

MILLTRONICS

Siemens Milltronics Process Instruments Inc.
1954 Technology Drive, P.O. Box 4225
Peterborough, ON Canada K9J 7B1
Tel: (705) 745-2431 Fax: (705) 741-0466
www.milltronics.com

© Siemens Milltronics Process Instruments Inc. 2000
Subject to change without prior notice



Printed in Canada