

SITRANS LR250

SITRANS LR250

Process Intelligence
for liquid level
measurement



SITRANS LR250

SITRANS LR250

Introduction

Features & Benefits

Installation

Process Intelligence

Field Proven

Conclusion

- **25GHz Pulse 2-wire loop powered radar**
- **Continuous level measurement**
 - Liquids and slurries
 - Range 50mm(2") from horn to 20m(65 ft)
 - No influence from vapor, temperature, pressure
- **Process Intelligence**
 - Quick Start Wizard for easy set up
 - Extremely reliable echo processing
- **Extreme Process Conditions**
 - Up to 150°C (302°F) and up to 40 bar (588psi*)
 - Threaded or flanged connections available
- **5mm(0.2") accuracy to IEC 60770-1**
- **HART or PROFIBUS PA (July)**



*Process Connection Type dependent

SITRANS LR250

Easy and Quick Configuration in Minutes!

- **New Local User Interface (LUI)**
 - Quick Start Wizard
 - Infrared handheld programmer
 - Nonintrusive and convenient
 - Intrinsically safe



- **New EDDL for SIMATIC PDM**
 - Quick Start Wizard

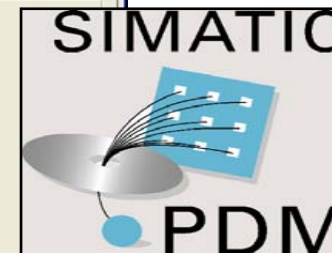
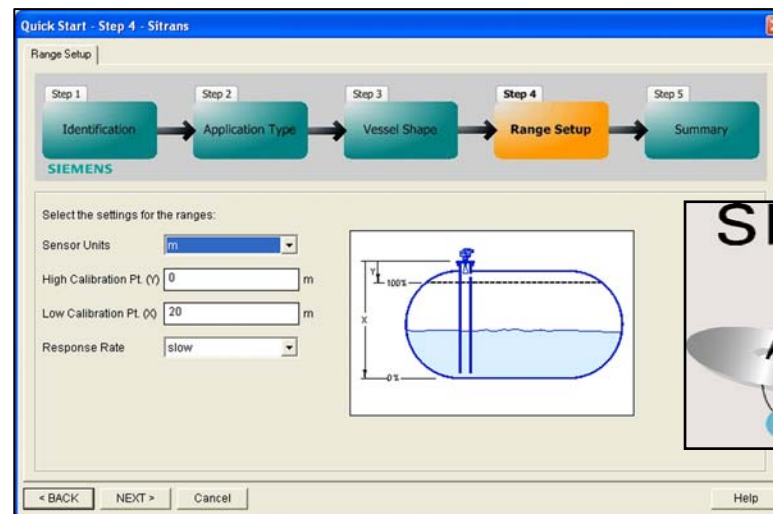

SITRANS LR250

Introduction

Features & Benefits

Installation

Process Intelligence

Field Proven

Conclusion

SITRANS LR250

25 GHz High Frequency Radar

SITRANS LR250

Introduction

Features & Benefits

Installation

Process Intelligence

Field Proven

Conclusion

- **25GHz pulse radar**
 - Small antenna
 - Narrow, focused beam

- **Very high signal, low noise**
 - Less sensitive to vessel location
 - Less sensitive to nozzle interference

- **Exceptional performance on low dK medium**

- **Higher vessel capacity**
 - Short measurement range to 50mm(2") from end of horn
 - Ideal for small vessels

- **Horn size guide**
 - 1.5"(40mm) range 10m(33 ft), dK>3
 - 2"(48 mm), 3"(75mm) and 4"(95mm) with range to 20m(66 ft)
 - Signal increases with horn size
 - Use largest horn size practical



SITRANS LR250

Rugged Encapsulated Design

SITRANS LR250

Introduction

Features & Benefits

Installation

Process Intelligence

Field Proven

Conclusion

- **Aluminum enclosure**
 - IP68 submersible

- **Encapsulated electronics**
 - Extremely high vibration and shock resistance
 - Extended corrosion Protection

- **Approved for hazardous areas**

- **Modular, removeable head**
 - In case of repair, process connection can remain mounted on vessel

- **Glass seal inside process connection**
 - Extremely high safety factor
 - Condensation and pressure barrier

- **Optional Alloy N06022/2.4602 (Hastelloy® C-22® or equivalent)**



SITRANS LR250

Diagnostic Capabilities

SITRANS LR250

Introduction

Features & Benefits

Installation

Process Intelligence

Field Proven

Conclusion

- **New LUI**
 - Graphical interface communicates status
 - Diagnostic info including echo profile
- **SIMATIC PDM with new EDDL**
 - HART or PROFIBUS PA
 - Maintenance scheduler (MP&F support for PCS-7)
 - Asset management, tagging and parameters
 - Echo profile diagnostics (with record function)
 - Trending

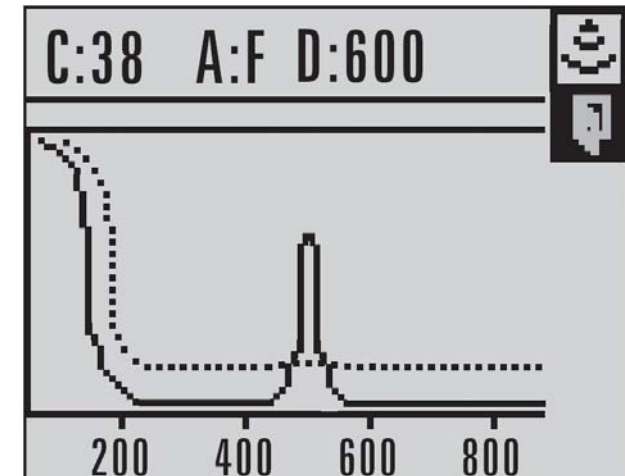
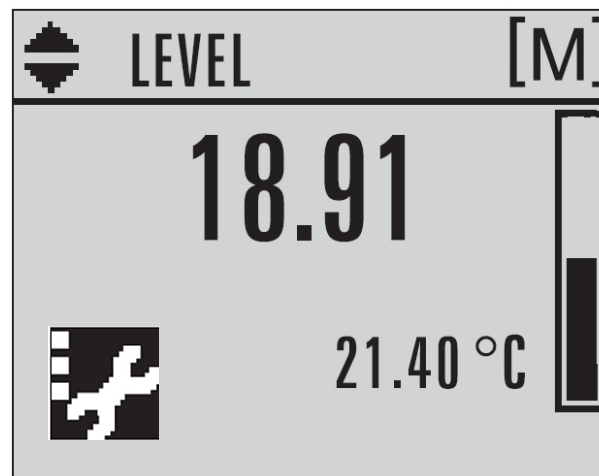

SITRANS LR250

Easy and Flexible

SITRANS LR250

Introduction

Features & Benefits

Installation

Process Intelligence

Field Proven

Conclusion

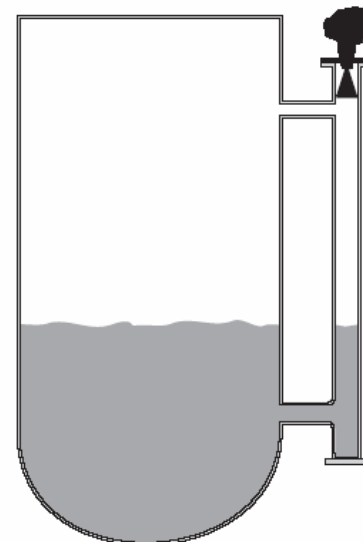
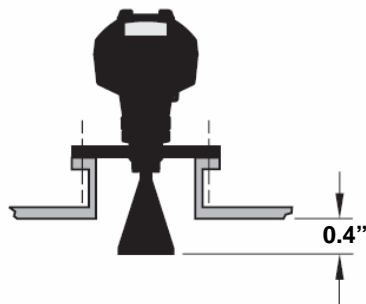
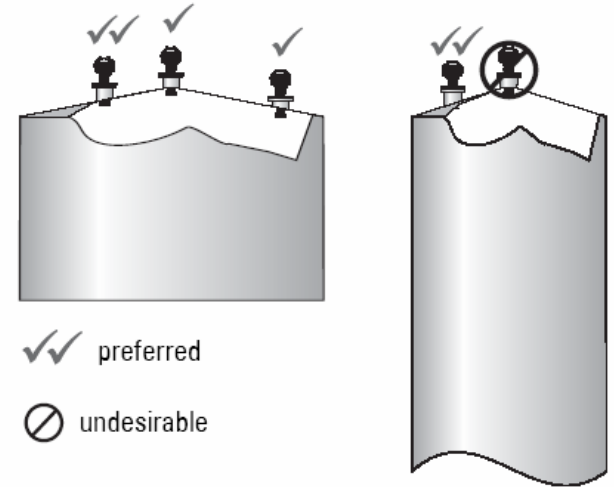
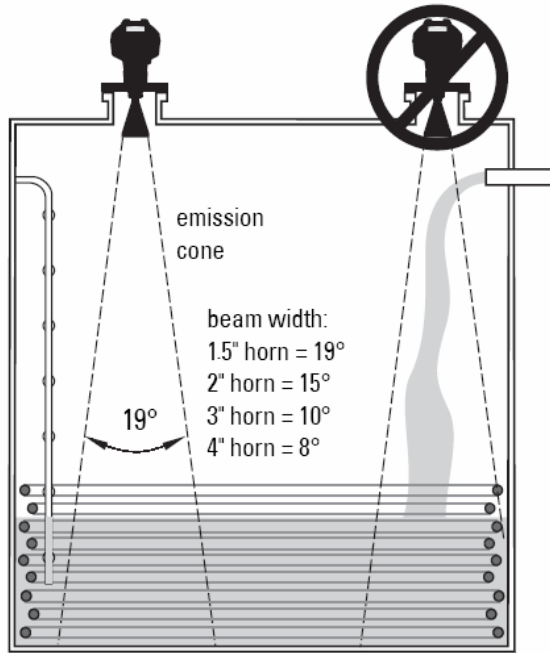

SITRANS LR250

Process Intelligence Signal Processing

SITRANS LR250

Introduction

Features & Benefits

Installation

Process Intelligence

Field Proven

Conclusion

- **Quick Start Wizard**
 - Plug & play performance
- **Based on over 1 million applications**
- **bLF algorithms for liquids**
- **Auto False-Echo Suppression**
- **Dynamic TVT threshold**
 - Condensation OK!
 - Variable process OK!
 - Changing dK OK!
- **CLEF algorithm**
 - Low level accuracy at tank bottom area for low dielectric medium

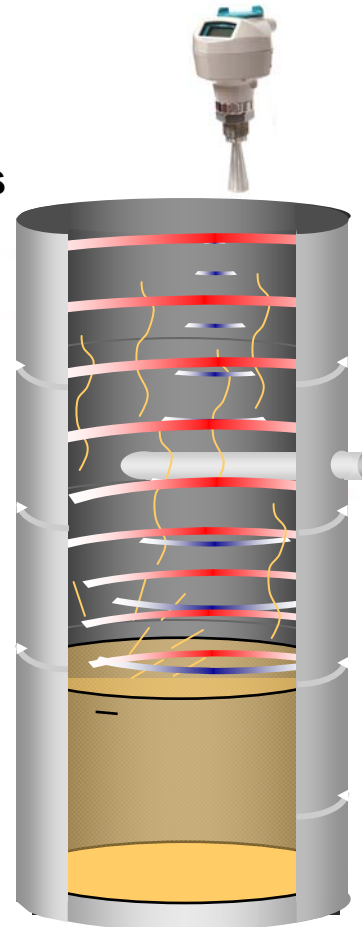

Process Intelligence

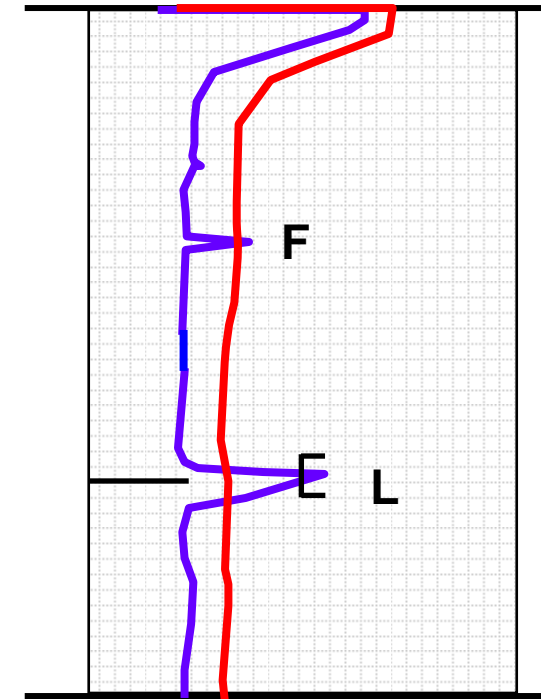

SITRANS LR250

Field Proven

Waste solvents



Alkali resin



Polyether liquid



**Hot water with steam
& condensation**



Petrol



NaMo liquid



SITRANS LR250

SITRANS LR250

Introduction

Features & Benefits

Installation

Process Intelligence

Field Proven

Conclusion

- **Compact, rugged design**
- **Easy to install**
- **Quick to configure with Wizards**
- **Process Intelligence for superior reliability**
- **Operational in minutes!**

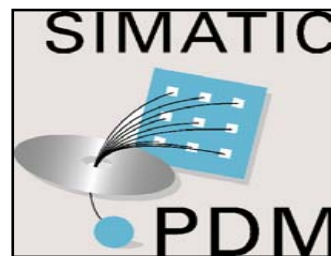

SITRANS LR250

SITRANS LR250

Process Intelligence
for liquid level
measurement

