

Quick Start Manual • April 2009



English
Dansk
Deutsch
Ελληνικά
Español
Français
Italiano
Nederlands
Português
Suomi
Svenska

million
in one

sitrans

PROBE LR

SIEMENS

SITRANS Probe LR Quick Start Manual

This manual outlines the essential features and functions of SITRANS Probe LR. We strongly advise you to acquire the detailed version of the manual so you can use your instrument to its fullest potential. The complete manual can be downloaded from the Siemens website at: www.siemens.com/level. The printed manual is available from your local Siemens representative.

Questions about the contents of this manual can be directed to:

Siemens Milltronics Process Instruments Inc.
1954 Technology Drive, P.O. Box 4225
Peterborough, Ontario, Canada, K9J 7B1
Email: techpubs.smpi@siemens.com

**Copyright Siemens Milltronics
Process Instruments Inc. 2008.
All Rights Reserved**

Disclaimer of Liability

We encourage users to purchase authorized bound manuals, or to view electronic versions as designed and authored by Siemens Milltronics Process Instruments Inc. Siemens Milltronics Process Instruments Inc. will not be responsible for the contents of partial or whole reproductions of either bound or electronic versions.

While we have verified the contents of this manual for agreement with the instrumentation described, variations remain possible. Thus we cannot guarantee full agreement. The contents of this manual are regularly reviewed and corrections are included in subsequent editions. We welcome all suggestions for improvement.

Technical data subject to change.

MILLTRONICS is a registered trademark of Siemens Milltronics Process Instruments Inc.

Safety Guidelines

Warning notices must be observed to ensure personal safety as well as that of others, and to protect the product and the connected equipment. These warning notices are accompanied by a clarification of the level of caution to be observed.



WARNING: relates to a caution symbol on the product, and means that failure to observe the necessary precautions can result in death, serious injury, and/or considerable material damage.



WARNING¹: means that failure to observe the necessary precautions can result in death, serious injury, and/or considerable material damage.

Note: means important information about the product or that part of the operating manual.

¹ This symbol is used when there is no corresponding caution symbol on the product.

SITRANS Probe LR

- ! WARNING: Changes or modifications not expressly approved by Siemens could void the user's authority to operate the equipment.**

Notes:

- This equipment has been tested and found to comply with the limits for a Class A digital device, pursuant to Part 15 of the FCC Rules. These limits are designed to provide reasonable protection against harmful interference when the equipment is operated in a commercial environment. This equipment generates, uses, and can radiate radio frequency energy and, if not installed and used in accordance with the instruction manual, may cause harmful interference to radio communications. Operation of this equipment in a residential area is likely to cause harmful interference, in which case the user will be required to correct the interference at his own expense.
- SITRANS Probe LR is to be used only in the manner outlined in this manual, otherwise protection provided by the equipment may be impaired
- This product is intended for use in industrial areas. Operation of this equipment in a residential area may cause interference to several frequency based communications..

SITRANS Probe LR is a 2-wire loop-powered, continuous level measuring instrument that utilizes advanced pulse radar technology at 5.8 GHz (6.3 GHz in North America). The instrument consists of an electronic component coupled to the antenna and process connection.

Communication is via HART¹, and signals are processed using Sonic Intelligence[®].

Specifications

For a complete listing, see the full manual for SITRANS Probe LR (Part#: 7ML19985HR0x). For Approvals information, please refer to the device nameplate.

Ambient/Operating Temperature

Note: Process temperature and pressure capabilities are dependent upon information on the process device tag. The reference drawing listed on the tag can be downloaded from the Siemens website. Go to the SITRANS Probe LR product page at: <https://pia.khe.siemens.com/index.asp?Nr=11158>.

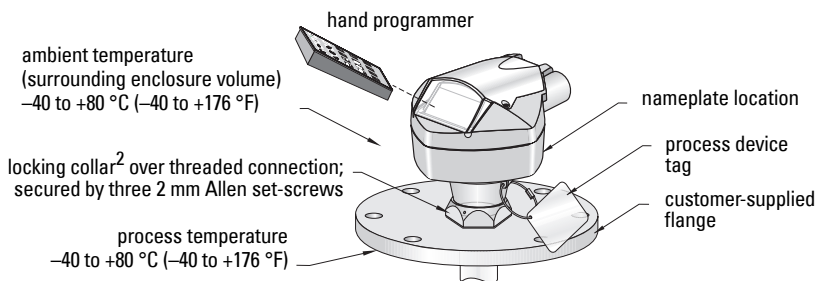

1. HART[®] is a registered trademark of the HART Communication Foundation.

2. When the locking collar is secured, it prevents the enclosure rotating on the threaded connection.

Power

Nominal 24 V DC at max. 550 Ohm

- Maximum 30 V DC
- 4 to 20 mA

Approvals

- General CSA_{US/C}, FM, CE, C-TICK
- Radio Europe (R&TTE), FCC, Industry Canada
- Hazardous Intrinsically Safe (Europe) ATEX II 1 G EEx ia IIC T4
(US/Canada) FM/CSA¹: (barrier required)
Class I, Div. 1, Groups A, B, C, D
Class II, Div. 1, Groups E, F, G
Class III T4
(Australia) ANZEx Ex ia IIC T4
(Tamb = -40 to + 80 °C) IP67, IP68
(International) IECEx TSA 04.0020X Ex ia IIC T4
(Brazil) INMETRO: BR-Ex ia IIC T4
Non-incendive (US) FM²:
Class I, Div. 2, Groups A, B, C, D T5
- Marine Lloyd's Register of Shipping
ABS Type Approval

Note: The use of approved watertight conduit hubs/glands is required for Type 4X / NEMA 4X, Type 6 / NEMA 6, IP67, IP68 (outdoor applications).

Mechanical

- Process Connections: threaded connection 1.5" NPT, BSP, or G (BS EN ISO 228-1)
- Antenna: polypropylene rod hermetically sealed construction

Process

- Temperature (at process connection): -40 to +80 °C (-40 to +176 °F)
- Pressure (vessel): maximum 3 bar, gauge (43.5 psi, gauge)

¹. See *Wiring Drawing: Intrinsically Safe (FM)* on page 2 of Appendix A, for drawing number 23651611, or *Wiring Drawing: Intrinsically Safe (CSA)* on page 3 of Appendix A, for drawing number 23651621.

². See *Wiring Drawing: Non-incendive (FM)* on page 1 of Appendix A, for drawing number 23650537.

Installation



WARNINGS:

- This product can only function properly and safely if it is correctly transported, stored, installed, set up, operated, and maintained.
- Never attempt to loosen, remove, or disassemble process connection or instrument housing while vessel contents are under pressure.
- This product is designated as a Pressure Accessory per Directive 97 / 23 / EC, and is not intended for use as a safety device.
- Materials of construction are chosen based on their chemical compatibility (or inertness) for general purposes. For exposure to specific environments, check with chemical compatibility charts before installing.
- The user is responsible for the selection of bolting and gasket materials which will fall within the limits of the flange and its intended use, and which are suitable for the service conditions.
- Improper installation may result in loss of process pressure.

Mounting location

Recommendations

- Ensure ambient temperature is within -40 to $+80$ °C (-40 to $+176$ °F).
- Provide easy access for viewing the display and programming via the hand programmer.
- Ensure the environment is suitable to the housing rating and materials of construction.

Precautions

- Avoid proximity to high voltage or current wiring, high voltage or current contacts, and to variable frequency motor speed controllers.
- Avoid interference to the emission cone from obstructions or from the fill path.
- Avoid central locations on vessels.

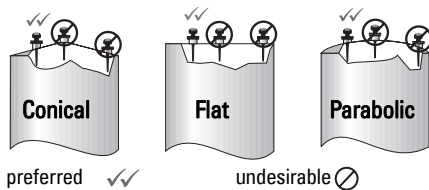

- Locate the antenna away from the side wall, to avoid interference from indirect echoes.
- Avoid interference from objects such as ladders or pipes, which can cause false echoes.
- Avoid interference from the fill path.

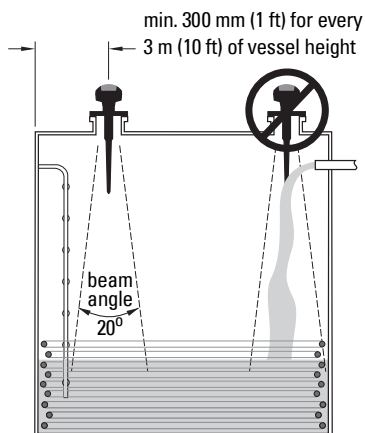

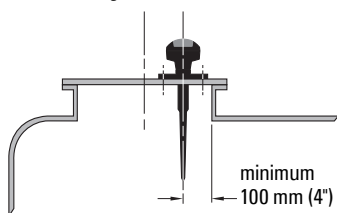
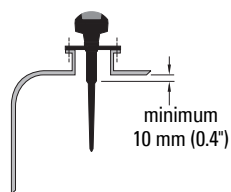
Mounting on a manhole cover**Mounting on a nozzle**

To provide optimum signal conditions on a manhole cover, locate the antenna off-center relative to the cover, typically 100 mm (4") from the side of the manhole.

- Use the 100 mm (4") shield on nozzles that are 100 mm (4") in length, or shorter.
- Use the 250 mm (10") shield on nozzles that are 250 mm (10") in length, or shorter.

Mounting instructions

- Before inserting SITRANS Probe LR into its mounting connection, check to ensure the threads are matching to avoid damaging them.
- Simply screw SITRANS Probe LR into the process connection, and hand tighten.
- For pressure applications, it will be necessary to use PTFE tape (or other appropriate thread-sealing compound) and tighten the process connection beyond hand-tight. The maximum torque is 40 N-m (30 ft-lbs).
- To rotate the enclosure, use a 2 mm Allen key to loosen the three set-screws that secure the locking collar. Once the enclosure is positioned as desired, tighten the set-screws.

Wiring**Power****WARNINGS:**

DC terminals shall be supplied from an SELV¹ source in accordance with IEC-1010-1 Annex H.



All field wiring must have insulation suitable for rated voltages.

¹. Safety Extra Low Voltage

Connecting SITRANS Probe LR

Notes:

- For detailed wiring instructions, please refer to the full Instruction Manual.
- Use shielded, twisted pair cable (wire gauge AWG14 to AWG22).
- Separate cables and conduits¹ may be required to conform to standard instrumentation wiring practices, or electrical codes.
- The non-metallic enclosure does not provide a continuous ground path between conduit connections: use grounding type bushings and jumpers.

Connecting SITRAN Probe LR (continued)

Unscrew the two lid screws to release the hinged lid and access the terminal block.

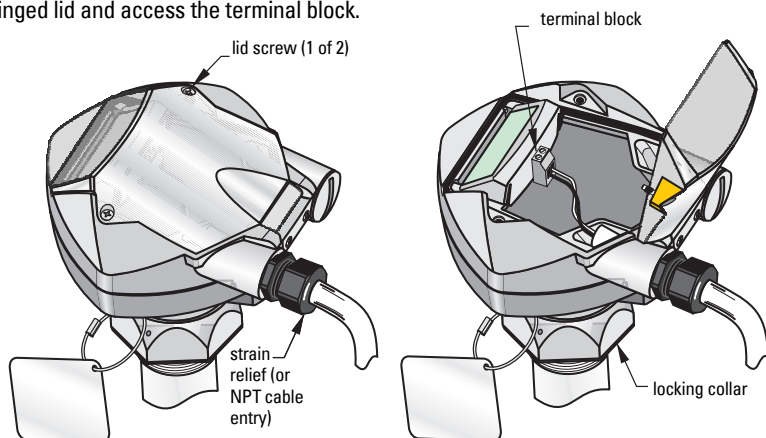

1. If you want to rotate the instrument on the process connection, use the 2 mm Allen key provided to loosen the 3 Allen set-screws securing the locking collar. Position the unit, and retighten the screws.

Note: Do not rotate the enclosure after programming and vessel calibration, otherwise an error may occur, caused by a polarity shift of the transmit pulse.

2. Strip the cable jacket for approximately 70 mm (2.75") from the end of the cable, and thread the wires through the strain relief².

¹. If cable is routed through conduit, use only approved suitable-size hubs for waterproof application.

². If cable is routed through conduit, use only approved suitable-size hubs for waterproof applications.

3. Connect the wires to the terminals: the polarity is identified on the terminal block.
4. Tighten the gland to form a good seal.
Close the lid and tighten screws: **please do not overtighten screws.** (Recommended torque is 1.1 to 1.7 N-m (10 to 15 in-lb) of torque)

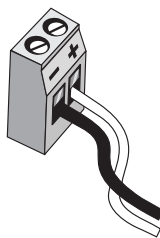

RUN Mode and PROGRAM Mode

SITRANS Probe LR has two modes of operation: RUN and PROGRAM.

After you complete the installation procedures and power up SITRANS Probe LR, it starts in **RUN** mode and detects the material level. It returns the distance (in meters) to the material level referenced from Empty (process empty level). This is the default start-up display mode.

RUN Mode Display

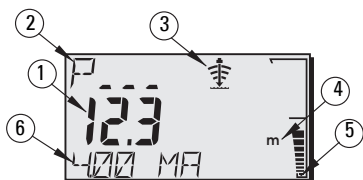

Use the hand programmer to control the display.

Normal operation

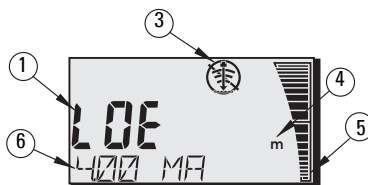

Failsafe operation



- 1 – Primary Reading (displays level, distance, or volume, in either units or percent)
- 2 – Secondary Reading (displays Parameter number for Auxiliary Reading)
- 3 – Echo status indicator: Reliable Echo  or Unreliable Echo 
- 4 – Units or Percent
- 5 – Active bar graph represents material level
- 6 – Auxiliary Reading (depending on the parameter selected, it displays milliAmp value, distance, or echo confidence, with units where applicable)

If the echo confidence drops below the echo confidence threshold, the failsafe timer starts running. When the timer expires, the letters **LOE** (Loss of Echo) alternate with the reading every two seconds, and the Reliable Echo indicator is replaced by the Unreliable indicator. When a valid reading is received, the level reading display returns to normal operation.

PROGRAM Mode Display

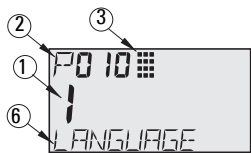

- 1 – Primary Reading (displays parameter value)
- 2 – Secondary Reading (displays parameter number)
- 3 – Programming indicator
- 6 – Auxiliary Reading (displays parameter names for P001 to P010, if a language is selected. It displays the index value for indexed parameters, such as P054)

Programming

Note: Do not use the handheld programmer at the same time as SIMATIC PDM, or erratic operation may result.

- Set parameters to suit your specific application.
- Activate **PROGRAM** mode at any time, to change parameter values and set operating conditions.
- For local programming, use the Siemens hand programmer.
- For programming from a distance, use either a PC running SIMATIC¹ PDM or a HART handheld communicator.

Hand programmer.

For direct access to SITRANS Probe LR, point the programmer at the SITRANS Probe LR display and press the keys. (For detailed instructions, see the next page.)

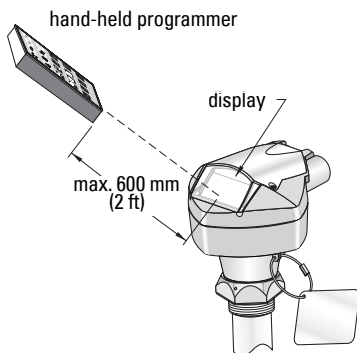

Key	Programming Mode
0 to 9	Values
	Decimal point
	Negative value
	CLEAR value
	TOGGLE between Units and % on parameter value
	End PROGRAM session and enable RUN mode
	Update echo quality parameters
	Parameter scroll-up
	Parameter scroll-down
	DISPLAY opens parameter fields
	ENTER the displayed value

¹ SIMATIC® is a registered trademark of Siemens AG.

Security: (P000: Lock)

Value	Description
Value stored in P069 *	Lock off: programming permitted
other	Lock activated: no changes permitted

* Factory setting for P069 is 1954: after a new value is entered and accepted, it becomes the default setting.

Activating SITRANS Probe LR

Power up the instrument. SITRANS Probe LR starts in **RUN** mode.



Notes:

- Keep infrared devices such as laptops, cell phones, and PDAs, away from SITRANS Probe LR to prevent inadvertent operation.
- The following instructions apply when using the Hand Programmer.
- Do not use the Hand Programmer at the same time as SIMATIC PDM, or erratic operation may result.
- You do not need to key in initial zeros when entering a parameter number: for example, for P005, key in **5**.

Accessing a parameter

1. Press **PROGRAM**  then **DISPLAY** , to activate **PROGRAM** mode.



2. Either use the **ARROW** keys   to scroll to a different parameter, or:



3. Press **DISPLAY**  to open the Parameter Number field. (The current parameter value remains visible.)

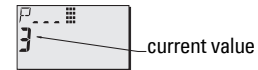

4. Key in the desired parameter number followed by **ENTER** .

For example: press  .

5. The LCD displays the new parameter number and value.





Changing a Parameter Value

Notes:

- Security must be disabled to enable programming: set P000 to the Unlocked Value stored in P069. (A remote master can still change configuration, if P799 is set to allow this.)
- Invalid entries will be rejected or limited.
- **CLEAR**  can be used to clear the field.





1. Key in the new value.
2. Press **ENTER**  to set the value.

Parameter Reset to Factory Default

1. Scroll to the parameter or enter its address.
2. Press **CLEAR**  then **ENTER** . The value returns to the default setting.

Master Reset (P999)

Returns all parameters except P000, P069, and P838 to default settings. (The learned TVT curve is not lost.)

1. Press **PROGRAM** , then **DISPLAY**  to activate **PROGRAM** mode.
2. Press **DISPLAY**  to open parameter fields.
3. Key in **999**.
4. Press **CLEAR**  then **ENTER** , to Clear All and initiate reset. The LCD displays **C.ALL**
5. Reset complete. (Reset takes several seconds to complete.)

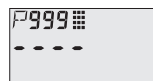

Quick Setup: steps 1 to 9

Note: Factory settings are marked by an asterisk (*) in the tables.

1. Select language (P010: Language)

Value	0	*	Numeric/None
	1		English
	2		German
	3		French
	4		Spanish

	ENGLISH	DEUTSCH	FRANÇAIS	ESPAÑOL
P000	LOCK	VERRIEGELG	VERROUIL	BLOQUEO
P001	OPERATION	BETRIEB	FONCTIONMT	FUNCIONAM.
P003	MEAS RESP	REAKTIONSZ	TEMPS REP	TIEMPO R.
P004	ANTENNA	ANTENNE	ANTENNE	ANTENA
P005	UNITS	EINHEIT	UNITES	UNIDADES
P006	EMPTY	MESSBER.	VIDE	VACIO
P007	SPAN	MESSSPANNE	PLAGE	RANGO
P010	LANGUAGE	SPRACHE	LANGUE	IDIOMA

2. Set P001: Operation (measurement mode)

Notes:

- Setting P001 resets Span (P007), unless Span has previously been set to a different value.
- Changing P001 may reset Output Function (P201); this applies to HART only.

Value	1	*	Level returns distance to material level referenced from Empty (process empty level). The reading is returned in volumetric units if parameters 050 to 055 are set to enable this.
	2		Space returns distance to material level referenced from Span (process full level).
	3		Distance returns distance to material level from reference point.

mA Output with Level, Space, and Distance operation

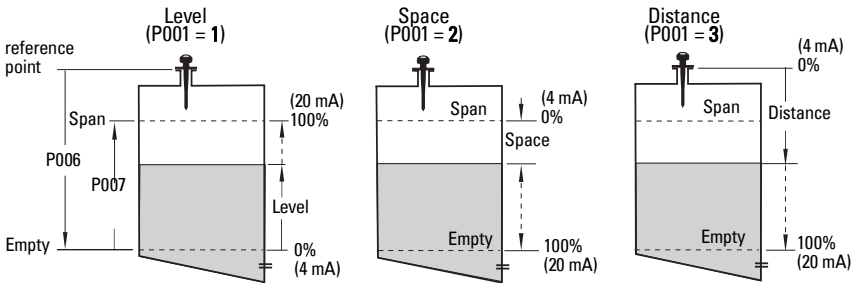

3. Set P003: Measurement Response

Value	1	*	slow	0.1m/minute
	2		medium	1m/minute
	3		fast	10m/minute

Set P003 to a measurement response speed just faster than the maximum filling or emptying rate (whichever is greater).

(P004 - view only)

Value	240	*	rod antenna
-------	-----	---	-------------

4. Select measurement units (P005)

Value	1	*	meters
	2		centimeters
	3		millimeters
	4		feet
	5		inches

5. Set process empty level (P006: Empty)

Note:

Setting P006 resets Span, if it has not previously been set to a different value.

Value	Range	0.0000 to 20.00 m (65.6 ft)
	Default	20.00 m (65.6 ft) max. range

Empty can be set to any distance: not necessarily the bottom of the tank.

6. Set measurement range (P007: Span)

Value	Range	0.0000 to 20.00 m (65.6 ft)
	Default	19.56 m (64.1 ft) (See note on next page.)

Span can be set at any distance above Empty level.

Notes:

- The default setting for Span is based on Operation (P001) and Empty (P006). Span is set to Empty minus 110% of Blanking distance¹, unless Operation is set to **distance** (P001=3). In that case, Span is set to Empty distance.
- Always prevent the monitored surface from approaching within 0.3 m (1 ft) of the transducer face.

7. Minimize false reflections: Set P838 (Auto False-Echo Suppression Distance)

Value	Range:	0.0000 to 20.00 m (65.6 ft)
	*	1.000 m (3.28 ft)

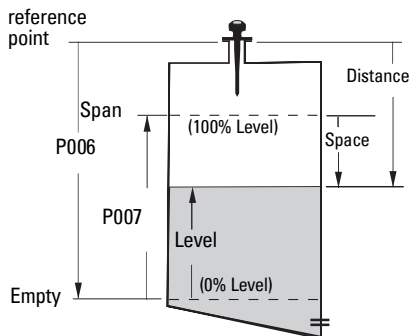

8. Enable False Echo Suppression: set P837 (Auto False Echo Suppression.

Value	0	Off
	1 *	Use "learned" TVT
	2	"Learn"

Using P837 and P838 (perform this function at low tank levels)



Notes:

- P837 and P838 should be used together to adjust the TVT (Time Varying Threshold) curve.
- Use this function only if there is at least 2 m (6.5 ft) from the reference point to the material.
- Set P837 and P838 during start up, if possible.
- If the vessel contains an agitator, the agitator should be running.

¹ Default setting for Blanking is 0.3 m (1 ft) plus shield length.

If SITRANS Probe LR displays an incorrect full level, or if the reading fluctuates between a false high level and a correct level, use P838 and P837 together to prevent false echo detection. They elevate the TVT in this region and de-sensitize the receiver from any 'base noise' caused by internal antenna reflections, nozzle echoes, or other vessel false echoes¹.

P838 sets the distance within which SITRANS Probe LR will learn a new echo profile. P837 instructs the Probe LR to learn the echo profile at that moment, and use the learned profile instead of the default TVT curve.

- a. Perform this function when the vessel is empty or nearly empty.
- b. First rotate the instrument for best signal (lowest false echo amplitude).
- c. Determine the distance from the reference point to the material level, and subtract 0.5 m (1.6 ft).
- d. Select P838 and key in [distance to liquid level minus 0.5 m/1.6 ft], and press **ENTER** .
- e. Select P837, then press **2** (Learn) and **ENTER** . P837 will automatically revert to **1** (use Learned TVT) after a few seconds.

9. Return to RUN

Press **PROGRAM**  to return to **RUN** mode: setup is complete.

SITRANS Probe LR Communications: HART

Note: See *mA Output with Level, Space, and Distance operation* on page 11 for an illustration of the mA output with different modes of operation.

- You will need the full manual (Part#: 7ML19985HR0x) to acquire the list of applicable parameters.
- The HART Electronic Device Description (EDD) may be obtained from the HART Communication Foundation at www.hartcomm.org.
- We recommend that you use SIMATIC Process Device Manager (PDM) to program your instrument.

Maintenance

SITRANS Probe LR requires no maintenance or cleaning under normal operating conditions. If cleaning becomes necessary under severe operating conditions:

1. Note the antenna material and the process medium, and select a cleaning solution that will not react adversely with either.
2. Remove the instrument from service and wipe the antenna clean using a cloth and suitable cleaning solution.

Unit Repair and Excluded Liability

For detailed information, please see the inside back cover.

¹ For more details on Auto False Echo Suppression, please see the full manual.

Instructions specific to hazardous area installations (Reference European ATEX Directive 94/9/EC, Annex II, 1/0/6)

The following instructions apply to equipment covered by certificate number SIRA 03ATEX2142X:

1. For use and assembly, refer to the main instructions.
2. The equipment is certified for use as Category 1G equipment.
3. The equipment may be used with flammable gases and vapors with apparatus group IIC and temperature class T4.
4. The equipment is certified for use in an ambient temperature range of $-40\text{ }^{\circ}\text{C}$ to $+80\text{ }^{\circ}\text{C}$.
5. The equipment has not been assessed as a safety related device (as referred to by Directive 94/9/EC Annex II, clause 1.5).
6. Installation and inspection of this equipment shall be carried out by suitably trained personnel in accordance with the applicable code of practice (EN 60079-14 and EN 60079-17 in Europe).
7. Repair of this equipment shall be carried out by suitably trained personnel in accordance with the applicable code of practice (e.g. EN 60079-19 within Europe).
8. Components to be incorporated into or used as replacements in the equipment shall be fitted by suitably trained personnel in accordance with the manufacturer's documentation.
9. It is the responsibility of the user to ensure that manual override is possible in order to shut down the equipment and protective systems incorporated within automatic processes which deviate from the intended operating conditions, provided that this does not compromise safety.
10. The 'X' suffix to the certificate number relates to the following special conditions for safe use:

Parts of the enclosure may be non-conducting and may generate an ignition-capable level of electrostatic charge under certain extreme conditions. The user should ensure that the equipment is not installed in a location where it may be subjected to external conditions (such as high-pressure steam) which might cause a build-up of electrostatic charge on non-conducting surfaces.

11. If the equipment is likely to come into contact with aggressive substances, then it is the responsibility of the user to take suitable precautions that prevent it from being adversely affected, thus ensuring that the type of protection is not compromised.

Aggressive substances: e.g. acidic liquids or gases that may attack metals, or solvents that may affect polymeric materials.

Suitable precautions: e.g. regular checks as part of routine inspections or establishing from the material's data sheet that it is resistant to specific chemicals.

12. Equipment Marking:

The equipment marking contains at least the information on the product label, shown on the inside front cover of this manual.

Notes

Appendix A: Connection Drawings and Loop Power Curve

Wiring Drawing: Non-incendive (FM)

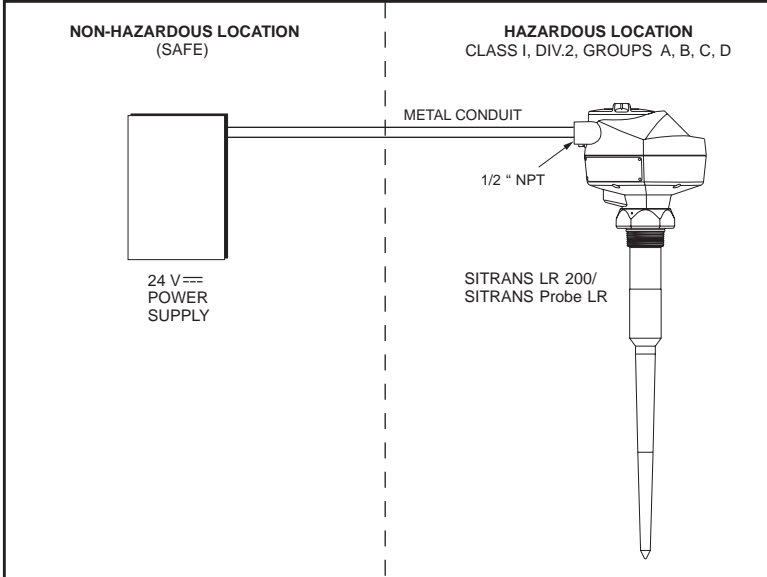

NOTES:

- 1) INSTALLATION SHALL BE DONE IN ACCORDANCE WITH THE NATIONAL ELECTRICAL CODE.
- 2) USE APPROVED WATER TIGHT CONDUIT FITTINGS FOR OUTDOOR APPLICATIONS.
- 3) FOR FURTHER INFORMATION REFER TO THE SITRANS LR 200 / Probe LR INSTRUCTION MANUAL

1		REMOVE NON- FROM HAZARDOUS SIDE PER ECN 2004-0113	RPC	SN	MAY 03/2004
0		FOR CONSTRUCTION	RPC	SN	MAY 03/2004
Rev.		Revision / ECN Description	Drawn	Appr.	Date
Product Group RADAR		Tolerance Unless Otherwise Noted: UDS 1 Place Decimal ± 0.03 Angles: 2 Place Decimal ± 0.01 ± 0.5° 3 Place Decimal ± 0.002	Scale NTS	Size: A	
Date: 05 / MAR / 2004		TITLE: SITRANS LR 200 / PROBE LR CLASS I, Div. 2 CONNECTION DRAWING			
Drawn: R. CLYSDALE		DRAWING No: 23650537		Rev. 1	
Checked: T. LITTLE		File No. 2365053701		Plot at: 1 : 1	
Approved: S. NGUYEN		Sheet 1 of 1			
Location: PETERBOROUGH					
SIEMENS MILLTRONICS PROCESS INSTRUMENTS INC. Peterborough, Ontario, Canada					

Note: Reference drawing 23650537 is available from the SITRANS Probe LR product page of our website at: <https://pia.khe.siemens.com/index.asp?Nr=11158>.

Wiring Drawing: Intrinsically Safe (FM)

Note: Reference drawing 23651611 is available from the SITRANS Probe LR product page of our website at: <https://pia.khe.siemens.com/index.asp?Nr=11158>.

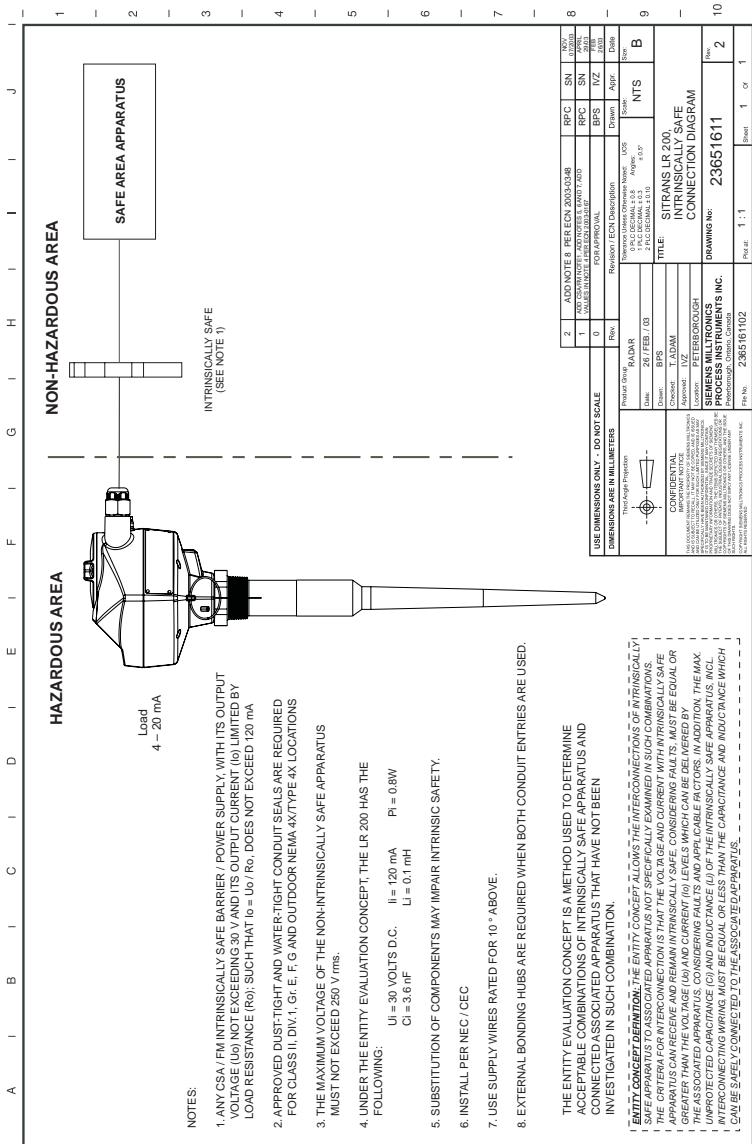

Wiring Drawing: Intrinsically Safe (CSA)

Note: Reference drawing 23651621 is available from the SITRANS Probe LR product page of our website at: <https://pia.khe.siemens.com/index.asp?Nr=11158>.

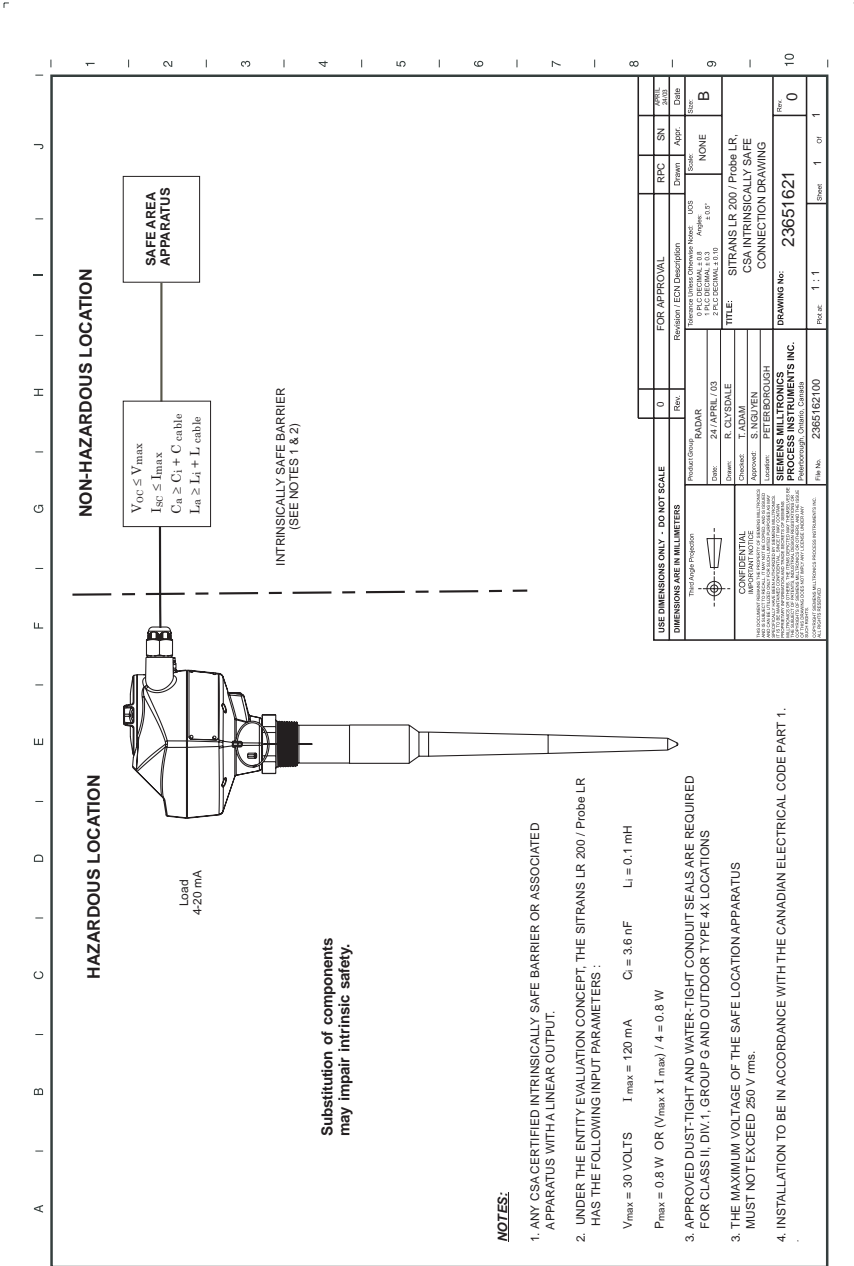

Loop power

Loop Voltage versus Loop Resistance

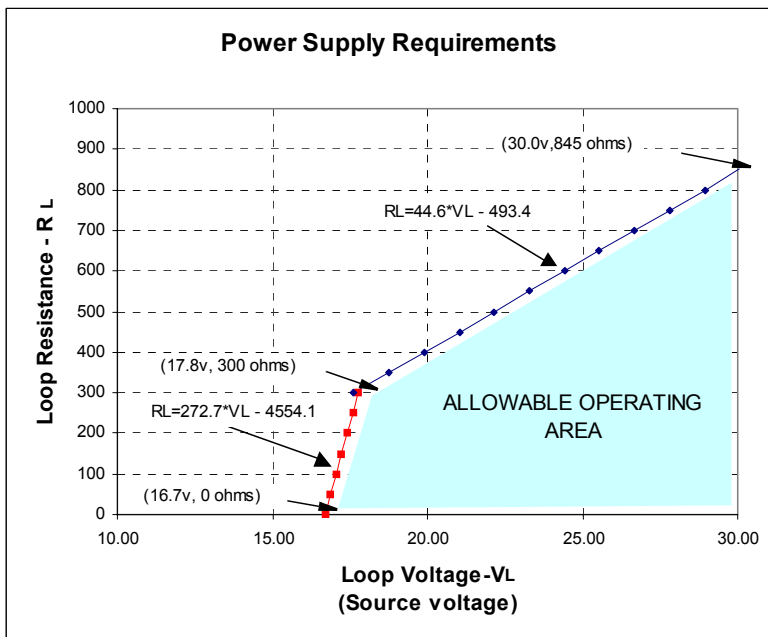

Unit Repair and Excluded Liability

All changes and repairs must be done by qualified personnel, and applicable safety regulations must be followed. Please note the following:

- The user is responsible for all changes and repairs made to the device.
- All new components must be provided by Siemens Milltronics Process Instruments Inc.
- Restrict repair to faulty components only.
- Do not re-use faulty components

Reparation af enheden og ansvarsbegrænsning:

Alle ændringer og reparationer skal udføres af kvalificeret personale, og de gældende sikkerhedsbestemmelser skal overholdes.

Bemærk venligst følgende:

- Brugeren er ansvarlig for alle de på apparatet udførte ændringer og reparationer.
- Alle nye komponenter skal være leveret af Siemens Milltronics Process Instruments Inc.
- Reparer kun defekte komponenter.
- Defekte komponenter må ikke genbruges

Geräte-reparatur und Haftungsausschluss:

Alle Änderungen und Reparaturen müssen von qualifiziertem Personal unter Beachtung der jeweiligen Sicherheitsbestimmungen vorgenommen werden. Bitte beachten Sie:

- Der Benutzer ist für alle Änderungen und Reparaturen am Gerät verantwortlich.
- Alle neuen Bestandteile sind von Siemens Milltronics Process Instruments Inc. bereit zu stellen.
- Reparieren Sie lediglich defekte Bestandteile.
- Defekte Bestandteile dürfen nicht wiederverwendet werden.

Επισκευή μονάδας και αποκλειόμενη ευθύνη:

Όλες οι αλλαγές και οι επισκευές πρέπει να πραγματοποιούνται από εξειδικευμένο προσωπικό, και πρέπει να τηρούνται όλοι οι σχετικοί κανόνες ασφαλείας. Σημειώστε τα παρακάτω:

- Ο χρήστης είναι υπεύθυνος για όλες τις αλλαγές και επισκευές που γίνονται στη συσκευή.
- Όλα τα καινούργια εξαρτήματα πρέπει να παρέχονται από τη Siemens Milltronics Process Instruments Inc.
- Περιορίστε τις επισκευές μόνο στα ελαττωματικά εξαρτήματα.
- Μην επαναχρησιμοποιείτε ελαττωματικά εξαρτήματα.

Reparación del dispositivo y límite de responsabilidad:

Las modificaciones y reparaciones deberán ser efectuadas por personal calificado de acuerdo con las normas de seguridad aplicables. Notas importantes:

- El usuario es el único responsable de las modificaciones y reparaciones del dispositivo.
- Recomendamos utilizar sólo recambios originales Siemens Milltronics Process Instruments Inc.
- Reparar sólo los componentes defectuosos.
- Los componentes defectuosos no se deben reutilizar.

Réparation de l'unité et limite de responsabilité :

Les modifications et réparations doivent être effectuées par un personnel qualifié en accord avec les consignes de sécurité applicables.

Remarques importantes :

- L'utilisateur est seul responsable des modifications et réparations effectuées sur l'unité.
- Utiliser seulement des composants fournis par Siemens Milltronics Process Instruments Inc.
- Réparer uniquement les composants défectueux.
- Les composants défectueux ne doivent pas être réutilisés.

Riparazioni dell'apparecchiatura e limiti di responsabilità:

Le modifiche e le riparazioni devono essere effettuate solo da personale qualificato, rispettando le normative sulla sicurezza. Note importanti:

- L'utente è responsabile delle eventuali modifiche e riparazioni effettuate sull'apparecchiatura.
- Utilizzare solo pezzi di ricambio originali forniti da Siemens Milltronics Process Instruments Inc.
- Riparare solo i componenti difettosi.
- È importante non riutilizzare i componenti difettosi.

Reparatie van apparatuur en uitsluiting van aansprakelijkheid:

Alle modificaties en reparaties moeten worden uitgevoerd door gekwalificeerd personeel en de geldende veiligheidsvoorschriften moeten worden aangehouden. Let op:

- De gebruiker is verantwoordelijk voor alle modificaties en reparaties die worden uitgevoerd aan het apparaat.
- Alle nieuwe onderdelen moeten zijn geleverd door Siemens Milltronics Process Instruments Inc.
- Beperk de reparatie uitsluitend tot de defecte componenten.
- Defecte componenten niet opnieuw gebruiken.

Reparação da Unidade e Responsabilidade Excluída

Todas as alterações e reparações devem ser realizadas por pessoal qualificado e devem ser seguidas as regras de segurança aplicáveis. Por favor, note o seguinte:

- O utilizador é responsável por todas as alterações e reparações efectuadas no dispositivo.
- Todos os novos componentes devem ser fornecidos pela Siemens Milltronics Process Instruments Inc.
- Reparação restrita apenas a componentes danificados.
- Não reutilize componentes danificados.

Yksikön korjaaminen ja vastuuvapaus:

Muutos- ja korjaustyöt saa suorittaa ainoastaan pätevä henkilökunta, ja voimassa olevia turvallisuusmääräyksiä on noudatettava. Pyydämme ottamaan huomioon seuraavat seikat:

- Käyttäjän on vastuussa kaikista laitteeseen tehdystä muutoksista ja korjauksista.
- Kaikki uudet osat on hankittava Siemens Milltronics Process Instruments Inc.:ltä.
- Korjaukset on kohdistettava ainoastaan viallisiin osiin.
- Viallisia osia ei saa käyttää uudelleen.

Reparation och ansvarsfrihet:

Alla ändringar och reparationer måste utföras av kompetent personal och under iakttagande av gällande säkerhetsbestämmelser. Observera att:

- Användaren ansvarar för alla ändringar och reparationer som görs på enheten.
- Alla nya delar måste komma från Siemens Milltronics Process Instruments Inc.
- Reparera endast med fel behäftade delar.
- Delar behäftade med fel får ej återanvändas.



www.siemens.com/processautomation

Siemens Milltronics Process Instruments Inc.
1954 Technology Drive, P.O. Box 4225
Peterborough, ON, Canada K9J 7B1
Tel: (705) 745-2431 Fax: (705) 741-0466
Email: techpubs.smpi@siemens.com

© Siemens Milltronics Process Instruments Inc. 2009
Subject to change without prior notice



Printed in Canada

Rev. 1.3