



119 Series Pressure and Temperature Switches

Types H119, H119A, F119, F119A

UL & CSA Listed Switch Capsule Div.1 & 2 Class I Groups A, B, C & D Class II Groups E, F, G; and Class III
 CENELEC EExd IIC T6 per EN 50 014/50 018



UNITED ELECTRIC CONTROLS Installation and Maintenance Instructions

Please read all instructional literature carefully and thoroughly before starting. Refer to the final page for the listing of Recommended Practices, Liabilities and Warrantees.

GENERAL

Pressure

Types H119 and H119A controls are activated when a diaphragm sensor responds to a pressure change. This response, at a predetermined set point, actuates a SPDT or a DPDT snap acting switch, converting a pressure signal into an electrical signal. Control set point may be varied by turning the internal slotted adjustment screw bushing according to procedures outlined in this document. (See Adjustment Procedures-Pressure Models PART II)

Temperature

Types F119 and F119A (Bulb and Capillary) controls sense temperature variations with a liquid filled sensing bulb. Liquid expansion or contraction is hydraulically transmitted to a diaphragm which actuates a SPDT or a DPDT snap action switch at a predetermined set point, converting a temperature signal into an electrical signal. Set point is adjusted by turning the internal hex adjustment screw according to procedures outlined in this document. (See Adjustment Procedures-Temperature Models PART II)

Pressure

Pressure controls may be mounted via two mounting slots for #10 screws in the enclosure or directly to a rigid pipe using the pressure connection. Low pressure units, models 520-535, are also available with an optional surface mounting bracket. Always use a wrench to tighten pressure connection to the pipe. To prevent damaging pressure sensor, use a backup wrench to hold the hex nut in place when surface mounting.

Temperature

Temperature controls must be surface mounted via #10 screw slots. For remote bulb temperature controls, fully immerse bulb and 6" of capillary in the control zone for most efficient control. Best control is usually obtained by placing the bulb close to the heating or cooling source in order to sense temperature fluctuations quickly. Be sure to locate bulb so that it will not be exposed to temperature beyond the instrument range limits.

WIRING

- WIRE IN ACCORDANCE WITH LOCAL AND NATIONAL CODES.
- DISCONNECT ALL SUPPLY CIRCUITS BEFORE WIRING.
- ELECTRICAL RATINGS STATED IN LITERATURE AND ON NAMEPLATE SHOULD NEVER BE EXCEEDED. OVER-LOAD ON A SWITCH CAN CAUSE FAILURE ON THE FIRST CYCLE.

1/2" NPTM conduit connection is provided on top of the unit with 18" leadwires. Unit is available with SPDT or DPDT (119A) operation. External grounding screw and clamp (GND symbol is cast into enclosure) is provided.

Leadwires to the terminal block are color coded:

	SPDT	DPDT	
		SWT1	SWT2
Common	Brown	Brown	Yellow
Normally Closed	Red	Red	Black
Normally Open	Blue	Blue	Violet
Ground	Green	Green	

Part I - Installation

Tools Needed

- 1 1/16" Open End Wrench
- Flat Head Screwdriver

MOUNTING

INSTALL UNIT WHERE SHOCK, VIBRATION AND TEMPERATURE FLUCTUATIONS ARE MINIMAL. ORIENT UNIT SO THAT MOISTURE IS PREVENTED FROM ENTERING THE ENCLOSURE. IF UNIT IS BEING INSTALLED WHERE HEAVY CONDENSATION IS EXPECTED, VERTICAL MOUNTING (PRESSURE CONNECTION DOWN) IS REQUIRED. DO NOT MOUNT UNIT IN AMBIENT TEMPERATURES EXCEEDING PUBLISHED LIMITS. CONTROLS MAY BE MOUNTED AND OPERATED IN ANY POSITION.

Part II - Adjustments

 PRESSURE MODELS HAVE A TWO-PIECE, ADJUSTABLE PLUNGER. THIS FEATURE IS CHARACTERIZED BY A 3/16" HEX HEAD SCREW INSTALLED IN THE 1/4" HEX PLUNGER. THE LENGTH OF THIS ASSEMBLY IS ADJUSTED AT OUR FACTORY AND IS CRITICAL TO THE FUNCTION OF THE CONTROL.

DURING NORMAL CALIBRATION, THIS ADJUSTMENT SHOULD NOT BE DISTURBED. HOWEVER, WHEN REPLACING THE ELECTRICAL SWITCH, IT MAY BE NECESSARY TO ADJUST THE PLUNGER LENGTH IN ORDER TO "RE-GAP" THE SWITCH. REFER TO INSTRUCTION IN "PART III-REPLACEMENTS" TO DETERMINE IF REGAPPING IS NECESSARY.

Tools Needed

Flat Head Screwdriver
3/32" Allen Wrench
3/16" and 1/4" Open End Wrench

Pressure Models

For set point adjustment, connect control to a calibrated pressure source.

Remove adjustment cover. Loosen Adjustment Lock set screw using a 3/32" Allen wrench. Adjust set point by turning 7/8" DIA. slotted adjustment screw clockwise (in) to increase set point or counterclockwise (out) to decrease set point. Index scale is cast into enclosure for reference. After completing adjustment, tighten Adjustment Lock set screw.

Note: (Models 190-194 with NACE option M411, welded stainless steel diaphragms). For rising set point applications, set point should be adjusted from low pressure up to set point. For falling pressure applications, set point should be adjusted from high pressure down to set point. Wide pressure cycling above and below set point can cause control band shift.

Temperature Models

For set point adjustments, connect control sensor to a calibrated temperature source and stabilize for 5 minutes. Remove adjustment cover. Loosen Adjustment Lock set screw using a 3/32" Allen wrench. Hold 1/4" hex lower plunger while turning 3/16" hex adjustment screw clockwise (in) to increase set point or counter clockwise (out) to decrease set point. Turning screw out until switch transfer provides temperature rise setting. Turning screw in until switch transfer provides temperature fall setting. When making adjustments, do not exceed maximum temperature rating on the nameplate.

PRESSURE

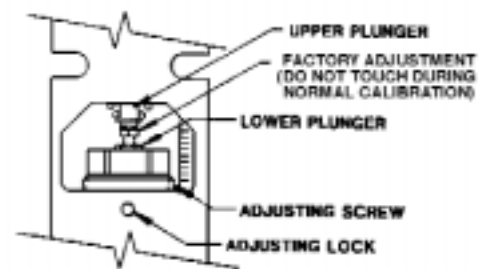

TEMPERATURE

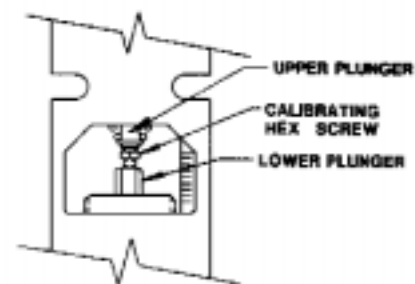

Part III - Replacements

Tools Needed

3 mm Allen Wrench
3/16" Wrench
1/4" Wrench
Flat Head Screwdriver

Switch Replacement

1. Unscrew 4 socket head screws using a 3 mm Allen wrench.
2. Remove switch assembly and "O" ring.
3. Replace with new switch and "O" ring making sure that ground screw faces forward.
4. Secure in place.
5. Switch replacement may require the "regapping" of the space between the top of the upper plunger and the switch lever arm. An adjustable lower plunger is provided. Gapping is done with no pressure applied to the control and prior to calibration or set point adjustment.

Dimensions 119 Series
 Explosion Proof
 Class I, II, and III
 Divisions 1 and 2, Zone 1

Internal Set Point Adjustment

Types H119, H119A, F119, F119A

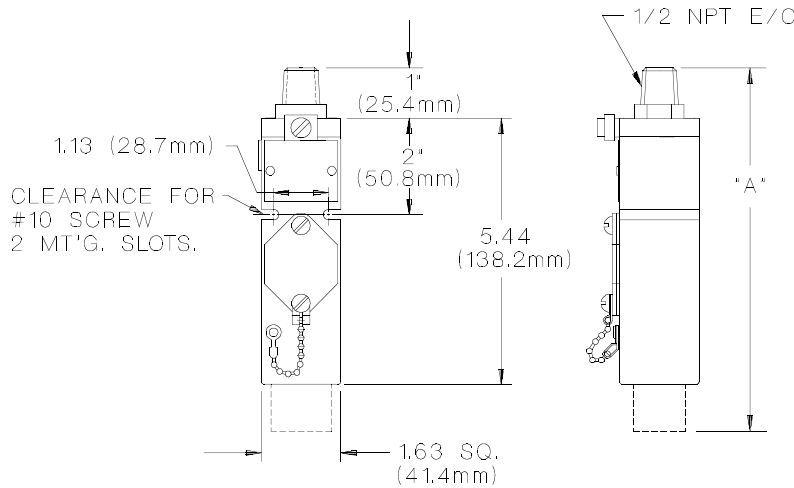

All dimensions stated in inches (millimeters)

Dimension A			
Models	Inches	mm	NPT
171-174	7.94	201,7	1/2
183-186	7.94	201,7	1/2
188, 189	7.16	182,6	1/2
190-196	7.00	179,9	1/2
358-376	7.69	195,4	1/4
483-486	7.94	201,7	1/2
488, 489	7.16	182,6	1/2
490-496	7.00	179,9	1/2
520-525	8.81	223,8	1/2
530-535	8.38	212,9	1/2
560-564	7.06	179,4	2" Sanitary fitting
565-567	7.06	179,4	1 1/2 Sanitary fitting
700-706	6.94	176,3	1/4

Models	Material	Type
H20BS-H23BS	304 Stainless Steel	Bulb & Capillary

Temperature

Pressure

Temperature

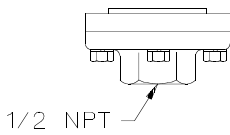

1/2 NPT

**Models 183-186,
483-486**

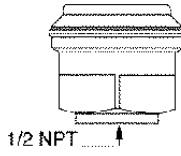

1/2 NPT

Models 171-174

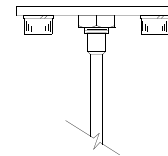

Models H20BS-H23BS

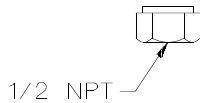

1/2 NPT

**Models 188-194,
488-494**

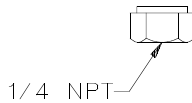

1/4 NPT

**Models 358-376,
700-706**

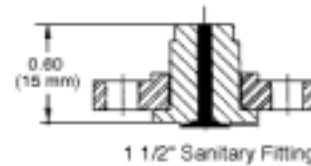

1 1/2" Sanitary Fitting

Models 560-564

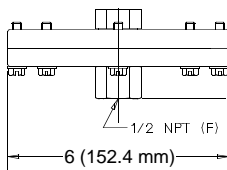

1/2 NPT (F)
6 (152.4 mm)

Models 520-525

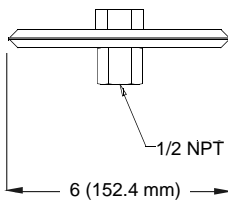

1/2 NPT
6 (152.4 mm)

Models 530-535

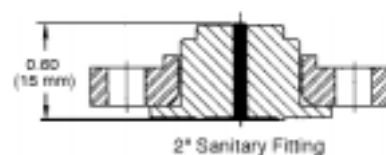

2" Sanitary Fitting

Models 565-567

Gapping

Turn 7/8" DIA. slotted adjustment screw in approximately to mid range. (Approximately 1/4" of hex plunger should be exposed.) This puts a load on the sensor. Using a 3/16" wrench on the plunger hex screw and a 1/4" wrench on the plunger hex, turn hex screw out until switch actuates. (If switch is already actuated, proceed to next step.) Turn hex screw in until switch just transfers. Continued to turn hex screw in per instructions below, depending on model.

Models 701-708, 377, 521-525, 531-535, 171- 174, and 471-474

Turn hex (IN) an additional 2 flats from this point (approximately 1/3 turn). This will provide a 9-11 mil gap.

Models 358-376

Turn hex (IN) 3 flats from this point (approximately 1/2 turn). This will provide for a 14-16 mil gap.

Models 183-189, 190-194, 483-489, 490-494

Turn hex (IN) 1 flat from this point. This will provide a 4-7 mil gap.

Models 520, 530

Vacuum range. Switch should be in actuated position with no gap.

6. Re-calibrate per PART II.

Thermal Assembly Replacement

1. Turn controls upside down and remove 4 slotted thermal assembly mounting screws.
2. Remove thermal assembly and mounting plate being sure to leave plunger in place.
3. Position new thermal assembly and mounting plate to bottom of control and hold while affixing 4 mounting screws.
4. Re-calibrate per PART II.

RECOMMENDED PRACTICES

United Electric Controls Company recommends careful consideration of the following factors when specifying and installing UE pressure and temperature units. Before installing a unit, the Installation and Maintenance instructions provided with unit must be read and understood.

- To avoid damaging unit, proof pressure and max temperature limits stated in literature and on nameplates must never be exceeded, even by surges in the system. Operation of the unit up to proof pressure or max temperature is acceptable on a limited basis (i.e.start-up, testing) but continuous operation must be restricted to the designated adjustable range. Excessive cycling at proof pressure or maximum temperature limits could reduce sensor life.
- A back-up unit is necessary for applications where damage to a primary unit could endanger life, limb or property. A high or low limit switch is necessary for applications where dangerous runaway condition could result.
- The adjustable range must be selected so that incorrect, inadvertent or malicious setting at any range point can not result in an unsafe system condition.
- Install unit where shock, vibration and ambient temperature fluctuations will not damage unit or affect operation. Orient unit so that moisture does not enter the enclosure via the electrical connection.
- Unit must not be altered or modified after shipment. Consult UE if modification is necessary.
- Monitor operation to observe warning signs of possible damage to unit, such as drift in set point. Check unit immediately.
- Preventative maintenance/periodic testing is necessary for critical applications where damage could endanger property/ personnel.
- For all applications, a factory set unit should be tested before use. Electrical ratings stated in literature and on nameplate must not be exceeded. Overload on a switch can cause damage, possible on the first cycle. Wire unit according to local and national electrical codes, using wire size recommended in installation sheet.
- Use only factory authorized replacement parts and procedures.
- Do not mount unit in ambient temp. exceeding published limits.
 - For remote mounted temperature units, capillary lengths beyond 10 feet can increase chance of error, and may require re-calibration of set point and indication.

LIMIT WARRANTY

UE warrants that the product thereby purchased is, upon delivery, free from defects in material and workmanship and that any such product which is found to be defective in such workmanship or material will be repaired or replaced by UE (F.O.B. UE); provided, however, that this warranty applies only to equipment found to be so defective within a period of 12 months after installation by buyer but not to exceed 18 months after delivery by the seller. Except for the limited warranty of repair and replacement stated above, UE disclaims all warranties whatsoever with respect to the product, including all implied warranties of merchantability or fitness for any particular purpose.

LIABILITY LIMITATION

The sole and exclusive remedy of buyer for any liability or seller for any claim, including incurred in connection with (I) breach of any warranty whatsoever expressed or implied, (II) a breach of contract, (III) a negligent act or acts (or negligent failure to act) committed by seller, or (IV) an act for which strict liability will be imputed to seller, is limited to the limited warranty or repair and replacement stated herein. In no event shall the seller be liable for any special, indirect, consequential or other damages or like general nature, including, without limitation, loss of profits or production, or loss or expenses of any nature, incurred by the buyer or any third party.



UNITED ELECTRIC CONTROLS

P.O. Box 9143, Watertown, MA 02272-9143 USA
617 926-1000 Fax 617 926-2568

MAP5M1296