



120 Series Explosion Proof Temperature and Indicating Temperature Switches and Controls

Local Mount Types **B121, B122, C120**
Remote Mount Types **E121, E122, E122P, F120; 820E, 822E**



UNITED ELECTRIC
CONTROLS

Installation and Maintenance Instructions

Please read all instructional literature carefully and thoroughly before starting. Refer to the final page for the listing of Recommended Practices, Liabilities and Warranties.

GENERAL



MISUSE OF THIS PRODUCT MAY CAUSE EXPLOSION AND PERSONAL INJURY. THESE INSTRUCTIONS MUST BE THOROUGHLY READ AND UNDERSTOOD BEFORE UNIT IS INSTALLED.



THIS EQUIPMENT IS SUITABLE FOR USE IN CLASS I, DIVISIONS 1 & 2, GROUPS B, C AND D; CLASS II, DIVISIONS 1 & 2, GROUPS E, F AND G; CLASS III; OR NON-HAZARDOUS LOCATIONS ONLY.



THIS EQUIPMENT IS ATEX CERTIFIED FOR EQUIPMENT CATEGORY 2. SUITABLE FOR APPROPRIATE USE IN GAS ZONE 1 & DUST ZONE 21 APPLICATIONS.

CE 0539 DEMKO 03 ATEX 0305048



II 2 G EEx d IIC T6



II 2 D T+ 85 °C

-40 °C ≤ TAMB. ≤ + 71 °C, IP66



THESE PRODUCTS DO NOT HAVE ANY FIELD REPLACEABLE PARTS. ANY SUBSTITUTION OF COMPONENTS MAY IMPAIR SUITABILITY FOR CLASS I, DIVISION 1.



TO PREVENT IGNITION OF HAZARDOUS ATMOSPHERES, DISCONNECT SUPPLY CIRCUITS BEFORE OPENING. KEEP COVER TIGHT WHILE CIRCUITS ALIVE.

Local Mount Types **B121, B122, C120 (Immersion Stem)**

The 120 Series temperature switch utilizes a liquid filled sensing stem which expands or contracts against a bellows to detect a temperature change. The response at a pre-determined set point(s), actuates or deactuates a SPDT, dual SPDT, or DPDT snap-acting microswitch(es), converting the temperature signal into an electronic signal. Control set point(s) may be varied by turning the adjustment hex (C120) or the external knob(s) and pointer(s) (B121, B122) according to the procedures outlined (see Part II—Adjustments).

Remote Mount Types **E121, E122, F120 (Bulb & Capillary)** Remote Mount & Indicating Temperature Types **820E, 822E (Bulb & Capillary)**

The 120 Series temperature switch and control utilizes a liquid filled sensing bulb which hydraulically transmits temperature change to a bellows. The response at a pre-determined set point(s), actuates or deactuates a SPDT, dual SPDT or DPDT snap-acting microswitch(es), converting the temperature signal into an electronic signal. Control set point(s) may be varied by turning the adjustment hex (F120) or the external knob(s) and pointer(s) (E121, E122, 820E, 822E) according to the procedures outlined (see Part II—Adjustments).

MAXIMUM TEMPERATURE: THE HIGHEST TEMPERATURE TO WHICH

A SENSING ELEMENT MAY BE OCCASIONALLY OPERATED WITHOUT ADVERSELY AFFECTING SET POINT CALIBRATION AND REPEATABILITY. MAXIMUM TEMPERATURE STATED IN LITERATURE AND ON NAMEPLATE MUST NEVER BE EXCEEDED, EVEN BY SURGES IN THE SYSTEM. OCCASIONAL OPERATION OF UNIT UP TO MAX. TEMPERATURE IS ACCEPTABLE (E.G., START-UP, TESTING). CONTINUOUS OPERATION SHOULD BE RESTRICTED TO THE DESIGNATED ADJUSTABLE RANGE.

Part I - Installation

TOOLS NEEDED

Screwdriver
Adjustable Wrench to 1 1/2"

MOUNTING



THE CONNECTION OF THE DEVICE SHALL BE MADE BY CABLE ENTRIES OR A STOPPING BOX OF A FLAMEPROOF TYPE, CERTIFIED EEx d IIC. THESE ACCESSORIES SHALL BE THREADED INTO THE RELEVANT OPENING(S) OF THE DEVICE, WITH AT LEAST 5 THREADS ENGAGED AND WITH AT LEAST 8 mm LENGTH OF THREAD ENGAGEMENT. THESE ACCESSORIES ARE NOT INCLUDED WITHIN THIS ASSOCIATED HAZARDOUS LOCATIONS/ZONE 1 ATMOSPHERES APPROVAL.



TO PREVENT IGNITION, SEAL ALL CONDUIT RUNS WITHIN 18 INCHES OF ENCLOSURE.



ALWAYS HOLD A WRENCH ON THE TEMPERATURE HOUSING HEX WHEN MOUNTING UNIT. DO NOT TIGHTEN BY TURNING ENCLOSURE. THIS WILL DAMAGE SENSOR AND WEAKEN SOLDER OR WELDED JOINTS.



INSTALL UNITS WHERE SHOCK, VIBRATION AND TEMPERATURE FLUCTUATIONS ARE MINIMAL. MOUNT UNIT TO PREVENT MOISTURE FROM ENTERING THE ENCLOSURE. IT IS IMPERATIVE TO USE PROPERLY RATED EXPLOSION-PROOF SEALING FITTINGS FOR ELECTRICAL WIRE ENTRY. DO NOT MOUNT UNIT IN AMBIENT TEMPERATURES LOWER THAN -40°F (-40°C) OR HIGHER THAN 160°F (71°C).



*DO NOT KNOCKOUT ANY PLUGS ON EXPLOSION-PROOF TYPES 820E OR 822E

C120, F120 and 820E, 822E Enclosures are provided with two 3/4" NPT electrical conduit openings, one of which is provided with a 3/4" explosion proof plug. Either of the two electrical conduits could be used during installation, as long as the unused one is properly sealed. The explosion proof plug must be properly sealed during product installation.

Remote mount types E121, E122, F120 temperature controls should be

mounted vertically (temperature assembly facing down) or horizontally (vent holes facing down). The conduit connection must be properly sealed (potted) for horizontal installation. Controls may be surface mounted via the four 1/4" screw clearance holes on the enclosure or through the use of a mounting bracket (See Mounting Dimensions).

Breather Drain Option M450: Types C120, F120

Mount with breather drain facing down (See Figure 1). The conduit connection must be properly sealed (potted) for this type of installation.

Breather Drain Option M450: Types B121, B122, E121 & E122

Mount in vertical position with temperature assembly and breather drain facing down (See Figure 2).

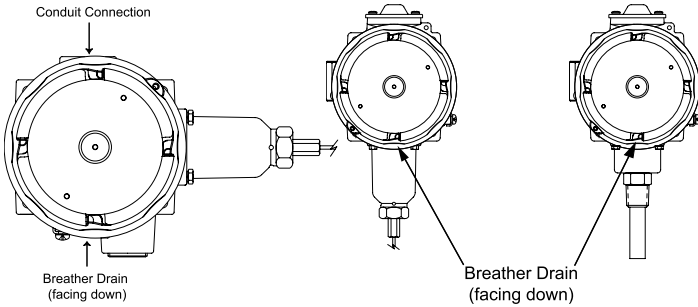

Figure 1: Types C120, F120

Figure 2: Types B121, B122, E121, E122

820E and 822E type units must be surface mounted. Drill mounting holes per Figure 3.

If a seal fitting is required, install the nipple and the seal fitting prior to surface mounting the controller.

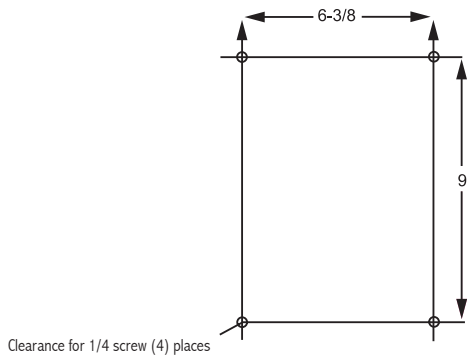

Figure 3: 820E, 822E Mounting

Mounting Bulb and Capillary

Fully immerse the bulb and 6" of capillary in the control zone. For best control it is generally desirable to place the bulb close to the heating or cooling source in order to sense temperature fluctuations quickly. Be sure to locate the bulb so it will not be exposed to temperature beyond the instruments range limits.

Avoid bending or coiling the capillary tube tighter than 1/2" radius. Exercise caution when making bends near the capillary ends.

If a separable well or union connector is used follow separate instructions included with them.

WIRING



SUPPLY LEADWIRES MUST BE RATED 75°C MINIMUM COPPER CONDUCTOR ONLY.



DISCONNECT ALL SUPPLY CIRCUITS BEFORE WIRING UNIT. WIRE UNITS ACCORDING TO NATIONAL AND LOCAL ELECTRICAL CODES. MAXIMUM RECOMMENDED WIRE SIZE IS 14 AWG. THE RECOMMENDED TIGHTENING TORQUE FOR FIELD WIRING TERMINALS IS 7 TO 17 IN-LBS.



ELECTRICAL RATINGS STATED IN LITERATURE AND ON NAMEPLATES MUST NOT BE EXCEEDED—OVERLOAD ON A SWITCH CAN CAUSE FAILURE ON THE FIRST CYCLE.



TO PREVENT SEIZURE OF ENCLOSURE COVER, DO NOT REMOVE LUBRICANT. THREADS SHOULD ALSO BE FREE OF DIRT, ETC.



THE EXTERNAL GROUNDING TERMINAL IS NOT TO BE USED AS THE PRIMARY EQUIPMENT GROUNDING TERMINAL. THE INTERNAL GROUNDING TERMINAL SHALL BE USED AS THE PRIMARY EQUIPMENT GROUNDING MEANS AND THE EXTERNAL GROUNDING TERMINAL IS ONLY FOR A SUPPLEMENTAL (SECONDARY) GROUNDING CONNECTION WHERE LOCAL AUTHORITIES PERMIT OR REQUIRE SUCH A CONNECTION.

Remove cover and wire control according to product configuration (See Figure 4). Wire directly to the terminal block. An internal grounding terminal is located near the right-hand conduit opening inside the enclosure. Replace cover and hand tighten to fully engage cover O-ring.

TYPES B121, C120, E121, F120, 820E

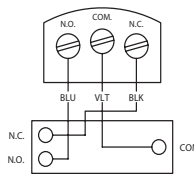

TYPES B122, E122, E122P

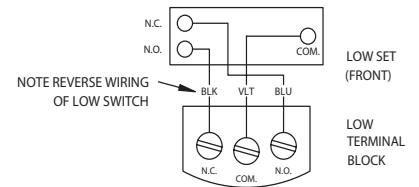
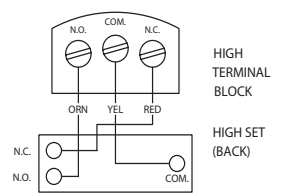

OPTION 1010, 1190, 1195 (FOR TYPE B121, C120, E121, F120 ONLY.)

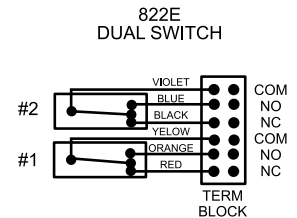
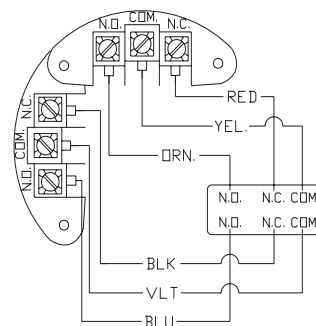

Use 75°C copper conductors only. Recommended tightening torque for field wiring terminals is 7-17 in-lbs.

Figure 4

Part II - Adjustments

TOOLS NEEDED

- 3/16" Open End Wrench (2)
- 1/4" Open End Wrench
- 5/64" Allen Wrench
- 5/16" Open End Wrench (2 required for 822E only)



AFTER COMPLETING ADJUSTMENTS ON ALL 120 SERIES TEMPERATURE CONTROLS, BE SURE TO RE-INSTALL ADJUSTMENT COVER. DO NOT OVER TIGHTEN COVER SCREWS.

NOTE: For set point adjustments and recalibration, connect control to a calibrated temperature source and stabilize unit.

NOTE: Type 822E has a single knob and pointer for both switches. Both switches are standardly, factory set together within 5% of the dial range. Turning the knob positions both switches simultaneously, maintaining a constant separation between them.

Replace cover and adjustment knob if removed during installation. Controller is ready for operation. Turn setting pointer to desired control temperature and start up the process. To suit particular process conditions or for greater controller accuracy it may be desirable to make slight alterations to the set point or indicator reading. Procedures for making these adjustments are described below.

Types C120, F120

NOTE: Adjust set point by holding plunger with 3/16" open end wrench and turning the calibrating screw with another 3/16" open end wrench (see figure 5). Turn clockwise (in) to increase or counter-clockwise (out) to decrease setting.

Adjustment Procedure for C120/F120

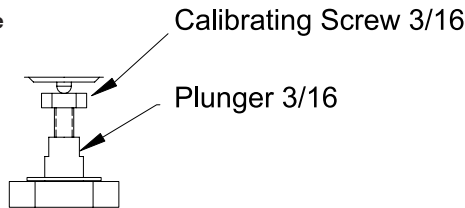

Figure 5

Type B121 and E121

Adjust set point by turning external knob and pointer to desired setting on scale.

Type B122 and E122

Individual switches may be set together or apart up to 100% of range. When not set together, the front (low) switch cannot be set higher than the rear (high) switch. Turning external knobs will increase or decrease each switch setting independently.

Type E122P

Individual switches may be set together or apart by up to 60% of range. The front switch is set by turning the internal calibrating screw to the right for lower set point and turning to the left for higher set point. When not set together, the front switch cannot be set higher than the rear switch. Turning the external knob will increase or decrease each switch setting simultaneously without disturbing their relationship.

NOTE: Prior to making any controller adjustments, the cover and adjustment knobs should be removed. When adjustments are completed, all applicable parts should be replaced.

NOTE: The adjustment knob slides off adjustment shaft for the 820E & 822E. Be sure to replace gasket when re-assembling.

Type 820E

Move the set point Adjustment Pointer up scale beyond the brown Indicating Pointer. This permits checking the set point by moving the lever arm upward with a finger or tool simulating thermal assembly movement. Connect test lights to indicate switch operation or listen for the switch to click. Loosen adjustment "A" and move the Adjustment Pointer until it agrees with the Indicating Pointer. When the switch clicks re-tighten the screw.

Type 822E

Remove the explosion-proof die-cast cover to permit access to the switches. Move the Adjustment Pointer up scale beyond the Indicating Pointer

by an amount greater than the difference between the switch settings by moving the actuating lever upward with a finger or a tool simulating thermal assembly movement. Connect test lights to indicate switch operation or listen for the individual switch clicks.

The set point of switch #1 is determined by the red Adjustment Pointer. The set point of switch #2 may be adjusted by up to 25% of the range span below the switch #1 set point by turning adjustment "D" in (clockwise). See Figure 4. The set point of switch #2 should not be above that of switch #1.

To align switch #1 to the Adjustment Pointer, loosen adjustment "A" and set the Adjustment Pointer to the scale, then re-tighten adjustment "A".

NOTE: Indicating Pointer Deflection (820E, 822E): The indicating pointers will read slightly low when the bulb temperature is 15° above the controller setting. This deflection is normal and repeatable (approximately 0.5% of scale range on single switch models) and is due to the transference of the switching mechanism load to the thermal system. It can be measured by moving the setting pointer from the high to the low end of the scale and observing the resultant indicating pointer deflection.

NOTE: Indicating Pointer Adjustment (820E, 822E): Use an accurate test thermometer such as a thermocouple with its probe mounted directly to the center of the sensing bulb. Before making any adjustments, allow process temperature to stabilize; i.e., successive on-off cycles repeated.

Correct any difference between the Indicating Pointer and the test thermometer by holding the compensator with a 5/16" wrench while turning the zero adjustment "C" on the thermal assembly with a second 5/16" wrench, per Figure 6 until the brown Indicating Pointer reads the same as the test thermometer. Turning clockwise lowers indicated reading. Compare the process temperature with the set point Adjustment Pointer. Loosen adjustment screw "A" to align set point Adjustment Pointer with the Indicating Pointer. Re-tighten screw "A".

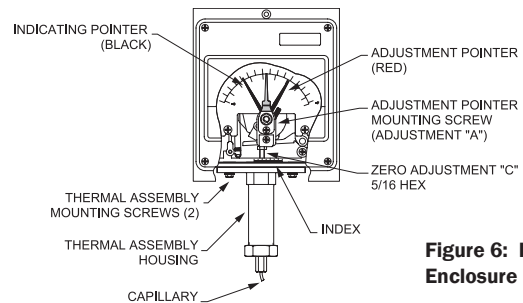
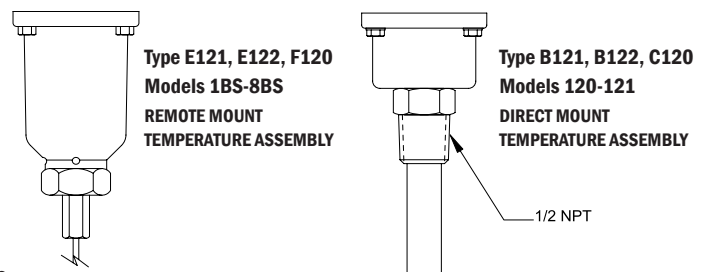

Figure 6: Indicating Enclosure Internals

Correction of Capillary

If the length of capillary immersed in the process differs from the amount immersed (6", see Mounting Bulb & Capillary in Part I - Installation) at the factory calibration bath, a calibration shift will occur. The error may be corrected as follows:

Move set pointer to the highest temperature setting. Note indicating scale reading with the head and sensor at room temperature. Loosen the two thermal assembly mounting screws. Re-position the housing index against the calibration on the instrument case (or skeleton casting) at a rate of 1 division line per capillary length listed in the following column. Move to the left if capillary is to be added to the process, or to the right if capillary is to be removed from process.



Internal Set Point Adjustment, Types C120, F120

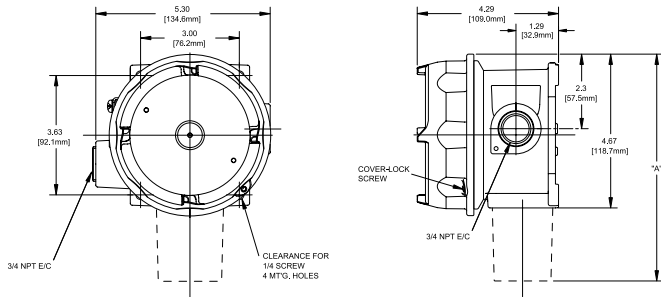

Dimension A

Model	Inches	mm	NPT
120,121	9.12	231,4	Immersion stem
1BS-8BS	8.47	214,8	Bulb & capillary

External Set Point Adjustment, Types B121, B122, E121, E122

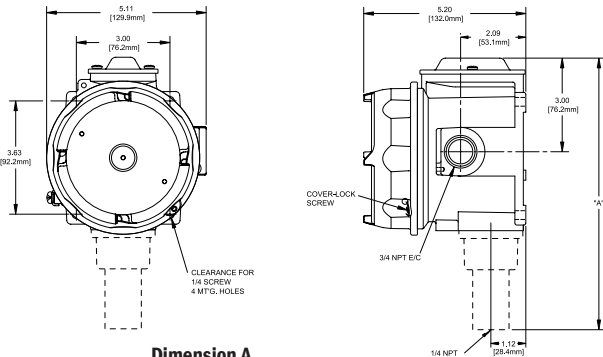

Dimension A

Model	Inches	mm	NPT
120,121	10	254,0	Immersion stem
2BS-8BS	9.3	237,0	Bulb & capillary
13272, 13322	10	254,0	Immersion stem (Freeze Protection)
13273, 13321	9.3	237,0	Bulb & capillary (Heat Tracing)

Type 820E single switch

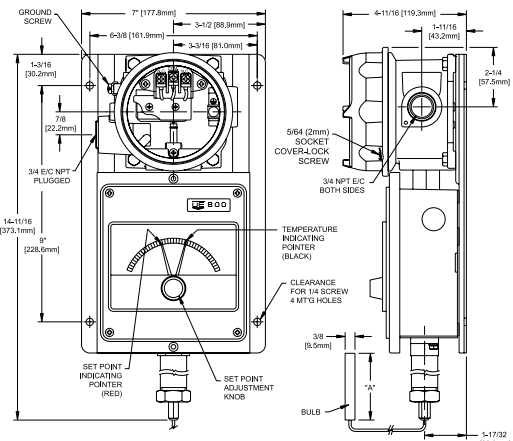

Dimension A

Model	Inches	mm
1BS	3-3/4	95,3
2BS	2-7/16	62,0
3BS	2-1/8	54,0
4BS	6-3/4	171,5
5BS	5	127,0
6BS	4-1/2	114,3
7BS	3	76,2
8BS	3-1/4	82,6

Type 822E dual switch

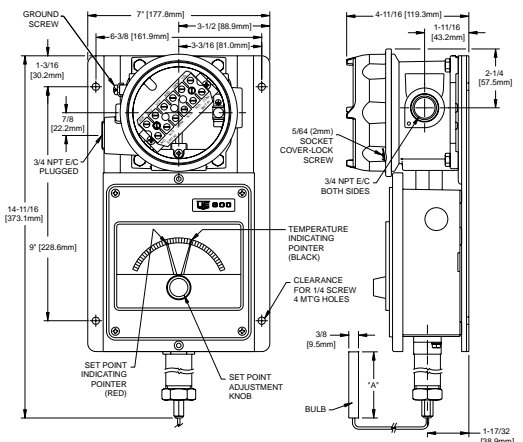

RECOMMENDED PRACTICES AND WARNINGS

United Electric Controls Company recommends careful consideration of the following factors when specifying and installing UE pressure and temperature units. Before installing a unit, the Installation and Maintenance instructions provided with unit must be read and understood.

- To avoid damaging unit, proof pressure and maximum temperature limits stated in literature and on nameplates must never be exceeded, even by surges in the system. Operation of the unit up to maximum pressure or temperature is acceptable on a limited basis (e.g., start-up, testing) but continuous operation must be restricted to the designated adjustable range. Excessive cycling at maximum pressure or temperature limits could reduce sensor life.
- A back-up unit is necessary for applications where damage to a primary unit could endanger life, limb or property. A high or low limit switch is necessary for applications where a dangerous runaway condition could result.
- The adjustable range must be selected so that incorrect, inadvertent or malicious setting at any range point cannot result in an unsafe system condition.
- Install unit where shock, vibration and ambient temperature fluctuations will not damage unit or affect operation. Orient unit so that moisture does not enter the enclosure via the electrical connection. When appropriate, this entry point should be sealed to prevent moisture entry.
- Unit must not be altered or modified after shipment. Consult UE if modification is necessary.
- Monitor operation to observe warning signs of possible damage to unit, such as drift in set point or faulty display. Check unit immediately.
- Preventative maintenance and periodic testing is necessary for critical applications where damage could endanger property or personnel.
- For all applications, a factory set unit should be tested before use.
- Electrical ratings stated in literature and on nameplate must not be exceeded. Overload on a switch can cause damage, even on the first cycle. Wire unit according to local and national electrical codes, using wire size recommended in installation sheet.
- Do not mount unit in ambient temp. exceeding published limits.

LIMITED WARRANTY

Seller warrants that the product hereby purchased is, upon delivery, free from defects in material and workmanship and that any such product which is found to be defective in such workmanship or material will be repaired or replaced by Seller (Ex-works, Factory, Watertown, Massachusetts, INCOTERMS); provided, however, that this warranty applies only to equipment found to be so defective within a period of 24 months from the date of manufacture by the Seller. Seller shall not be obligated under this warranty for alleged defects which examination discloses are due to tampering, misuse, neglect, improper storage, and in any case where products are disassembled by anyone other than authorized Seller's representatives. EXCEPT FOR THE LIMITED WARRANTY OF REPAIR AND REPLACEMENT STATED ABOVE, SELLER DISCLAIMS ALL WARRANTIES WHATSOEVER WITH RESPECT TO THE PRODUCT, INCLUDING ALL IMPLIED WARRANTIES OF MERCHANTABILITY OR FITNESS FOR ANY PARTICULAR PURPOSE.

LIMITATION OF SELLER'S LIABILITY

Seller's liability to Buyer for any loss or claim, including liability incurred in connection with (i) breach of any warranty whatsoever, expressed or implied, (ii) a breach of contract, (iii) a negligent act or acts (or negligent failure to act) committed by Seller, or (iv) an act for which strict liability will be inputted to seller, is limited to the "limited warranty" of repair and/or replacement as so stated in our warranty of product. In no event shall the Seller be liable for any special, indirect, consequential or other damages of a like general nature, including, without limitation, loss of profits or production, or loss or expenses of any nature incurred by the buyer or any third party.

UE specifications subject to change without notice.



**UNITED ELECTRIC
CONTROLS**

180 Dexter Avenue, P.O. Box 9143
 Watertown, MA 02471-9143 USA
 Telephone: 617 926-1000 Fax: 617 926-2568
<http://www.ueonline.com>