



54 Series Temperature Switches

Types

**B54, B54S, C54, C54S, C54A, C54AS,
E54, E54S, F54, F54S**



UNITED ELECTRIC
CONTROLS

Installation and Maintenance Instructions

Please read all instructional literature carefully and thoroughly before starting. Refer to the final page for the listing of Recommended Practices, Liabilities and Warranties.

GENERAL

Type B54, B54S, C54, C54S, C54A, C54AS (Immersion Stem)

Temperature variations are sensed by a liquid filled sensor which expands or contracts against a bellows which in turn actuates or deactuates a snap-action switch at a predetermined set point.

Type E54, E54S, F54, F54S (Bulb & Capillary)

Temperature variations of a liquid filled sensing bulb are hydraulically transmitted to a diaphragm which either actuates or deactuates a snap-acting switch at a predetermined set point.



MAXIMUM TEMPERATURE IS THE HIGHEST TEMPERATURE TO WHICH A SENSING ELEMENT MAY BE OCCASIONALLY EXPOSED TO WITHOUT ADVERSELY AFFECTING SET POINT CALIBRATION AND REPEATABILITY. MAXIMUM TEMPERATURE LIMITS STATED IN LITERATURE AND ON NAMEPLATE MUST NEVER BE EXCEEDED, EVEN BY TEMPERATURE OVERSHOOTS IN THE SYSTEM. OCCASIONAL OPERATION OF UNIT UP TO MAX. TEMPERATURE IS ACCEPTABLE (E.G., START-UP, TESTING). CONTINUOUS OPERATION SHOULD BE RESTRICTED TO THE DESIGNATED ADJUSTABLE RANGE.



THIS PRODUCT DOES NOT HAVE FIELD REPLACEABLE PARTS.

Part I - Installation

Tools Needed

Screwdriver
Adjustable wrench

MOUNTING



INSTALL UNIT WHERE SHOCK, VIBRATION AND TEMPERATURE FLUCTUATIONS ARE MINIMAL. DO NOT MOUNT UNIT IN AMBIENT TEMPERATURES EXCEEDING PUBLISHED LIMITS. 54 SERIES TEMPERATURE SWITCHES CAN BE MOUNTED IN ANY POSITION, PROVIDED THE ELECTRICAL CONDUIT IS NOT FACING UP. ORIENT UNIT SO THAT MOISTURE IS PREVENTED FROM ENTERING THE ENCLOSURE (*).

Remove Cover (Enclosed version only). Cover is held on by one captive screw located on the front of the cover.

54 Series temperature switches can be mounted in any position by using either the Mounting Screw holes on the bracket or the NPT connector on the immersion stem (local mounted only). Optional union connectors or separable well kits are available for remote bulb types.

A 7/8" diameter hole has been provided in the bracket plate for mounting a standard conduit fitting.

* If applicable



FOR LOCAL MOUNTING, ALWAYS HOLD A WRENCH ON THE TEMPERATURE HOUSING HEX WHEN MOUNTING UNIT. DO NOT TIGHTEN BY TURNING ENCLOSURE. THIS WILL DAMAGE SENSOR AND WEAKEN SOLDERED OR WELDED JOINTS.

For remote mounting, fully immerse the bulb and 6" of capillary in the control zone. It is generally desirable to place the bulb close to the heating or cooling source in order to sense temperature fluctuations quickly. Be sure to locate the bulb so that it will not be exposed to temperatures beyond the instrument range limits.

WIRING



DISCONNECT ALL SUPPLY CIRCUITS BEFORE WIRING UNIT. ELECTRICAL RATINGS STATED IN LITERATURE AND ON NAMEPLATE MUST NOT BE EXCEEDED. OVERLOAD ON A SWITCH CAN CAUSE FAILURE ON THE FIRST CYCLE. WIRE UNITS ACCORDING TO NATIONAL AND LOCAL ELECTRICAL CODES. MAXIMUM RECOMMENDED WIRE SIZE IS #14 AWG.

Conduit Connection (Enclosed units only)



FOR ENCLOSED UNITS, CONNECT THE CONDUIT TO THE HOLE IN ACCORDANCE WITH NATIONAL AND LOCAL CODES. BRING WIRES UP TO THE TERMINALS FROM THE REAR. MAXIMUM RECOMMENDED WIRE SIZE - #14 AWG.

Part II - Adjustments

Tools Needed

1/4" Open-ended wrench
1/16" Allen wrench
(single switch calibrated units)



MAKE SURE THAT LIVE ELECTRICAL SUPPLIES TO THE TEMPERATURE SWITCH ARE DISCONNECTED BEFORE PERFORMING ANY DISASSEMBLY. THIS MAY REQUIRE DISCONNECTING MORE THAN ONE CIRCUIT.

Dual Switch Units (C54A, C54AS)



ON DUAL SWITCH UNITS, "LOW SET" SWITCH MUST ALWAYS BE SET EQUAL OR BELOW THE "HIGH SET" SWITCH.

High Set

Immerse the sensing portion of the unit in a calibrated temperature bath or other calibrated source at the desired "Hi Set" temperature. Allow 5 minutes for the thermal system to stabilize. Using a 1/4" open end wrench, slowly turn the main adjustment screw towards the right (counter-clockwise) until the "Hi Set" switch transfers. If switch does not transfer, turn the main adjustment screw towards the left (clockwise) until the switch transfers, and then towards the right until it transfers again. The "Hi Set" switch should now transfer on "temperature rise" at the bath temperature. If it is desired that the switch transfer on "temperature fall" at the bath temperature, turn the main adjustment screw towards the left until the switch transfers again.

Low Set

Lower the temperature of the calibrated bath (or use another bath) to the desired "Low Set" temperature, and allow 5 minutes for the thermal system to stabilize. Using a 1/4" open end wrench, slowly turn the low set adjustment screw towards the left until the switch transfers. If switch does not transfer, turn the low set adjustment screw towards the right until the switch transfers, and then towards the left until it transfers again. The "Low Set" switch is now set to actuate at the bath temperature on "temperature fall". If it is desired that the "Low Set" switch transfer on "temperature rise" at the bath temperature, turn the low set adjustment screw towards the right until the switch transfers.

Fine Adjustment

If it is necessary to "fine adjust" the "High Set" setting, raise the bath temperature to a value slightly higher than the "High Set" temperature. Note the temperature at which the switch transfers (on rise). Lower the bath temperature and note when switch transfers again (on fall). Turn the main adjustment screw towards the left to raise or towards the right to lower the settings.

If necessary, perform the same "fine adjustment" procedure outlined above for the "Low Set" switch.

Single Switch Units

Uncalibrated (C54, C54S, F54, F54S)

To adjust single switch units, follow "High Set" instructions. For "fine adjustment", follow Fine Adjustments above.

Calibrated (B54, B54S, E54, E54S)

Turn the reference dial to desired set point by aligning setting on dial with dowel pin.

Dimensions

Types B54, C54, C54A

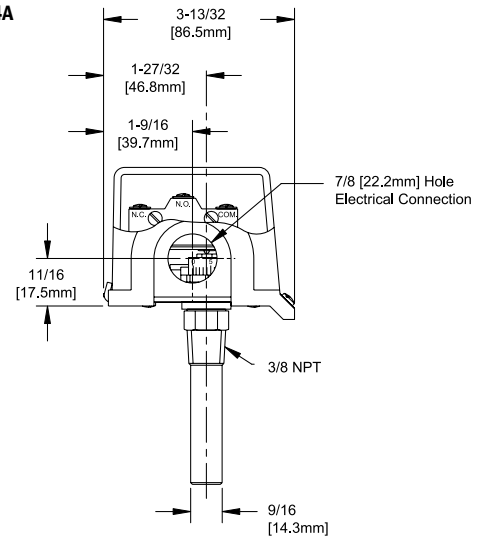

Types B54, C54, C54A

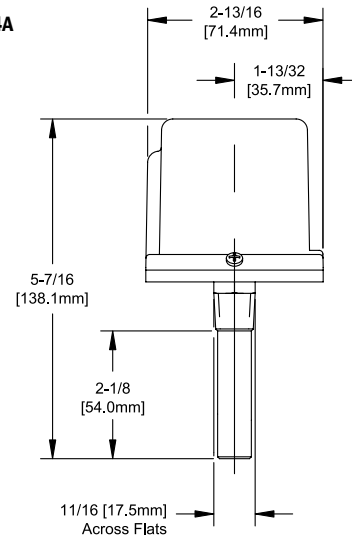

Type C54A

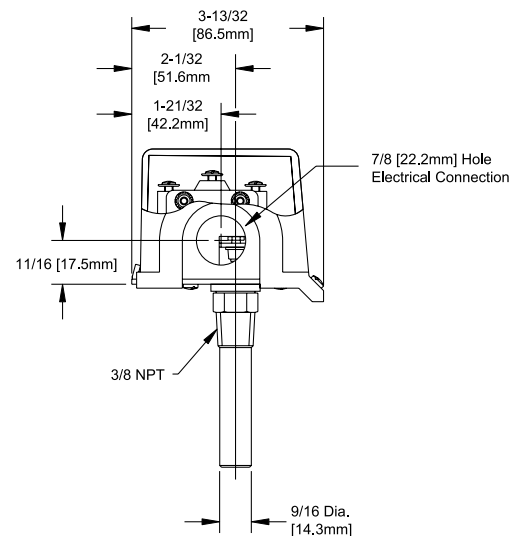

Type B54S

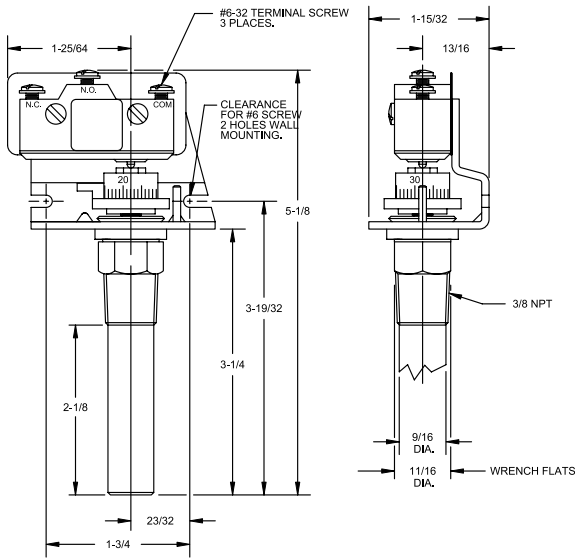

Type C54S

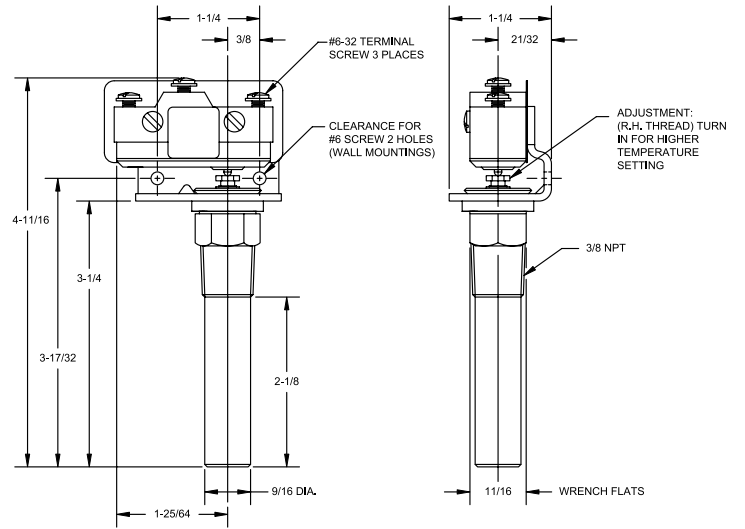

Type C54AS

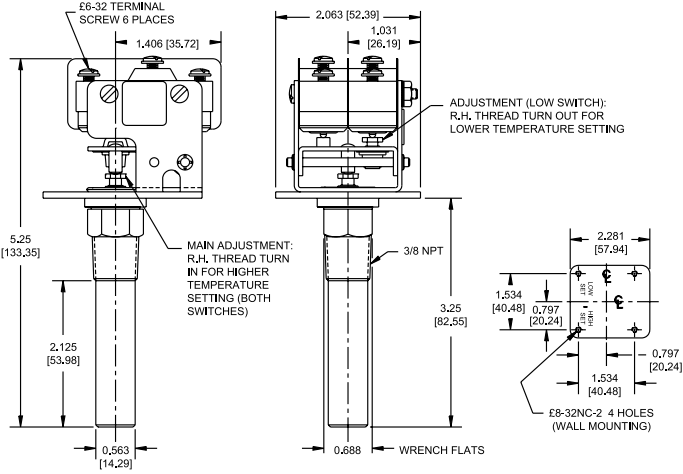

Types E54, F54

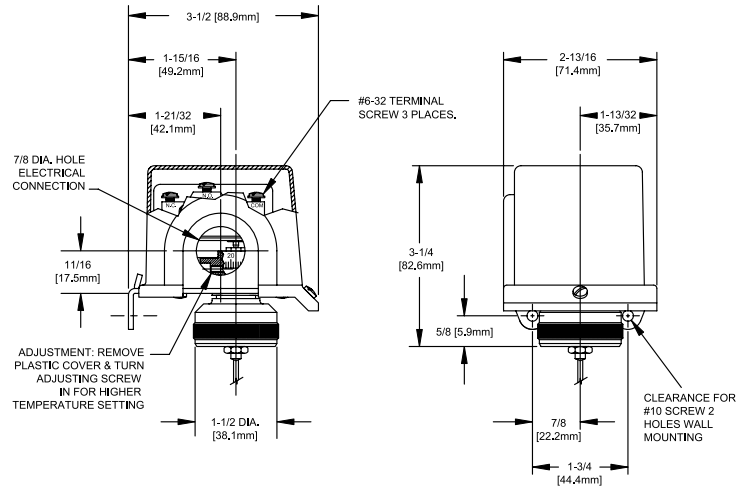

Type E54S

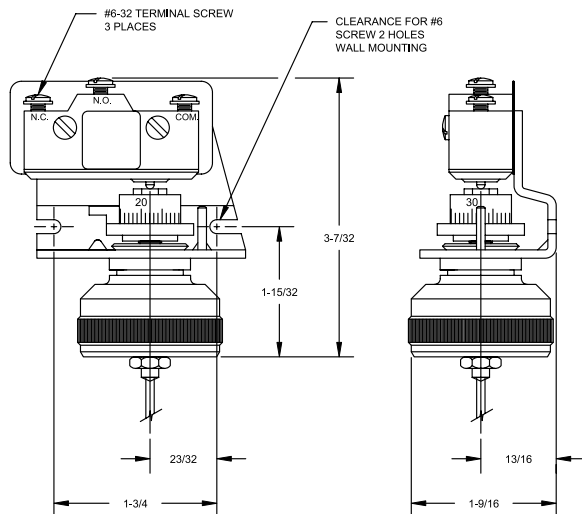

Type F54S

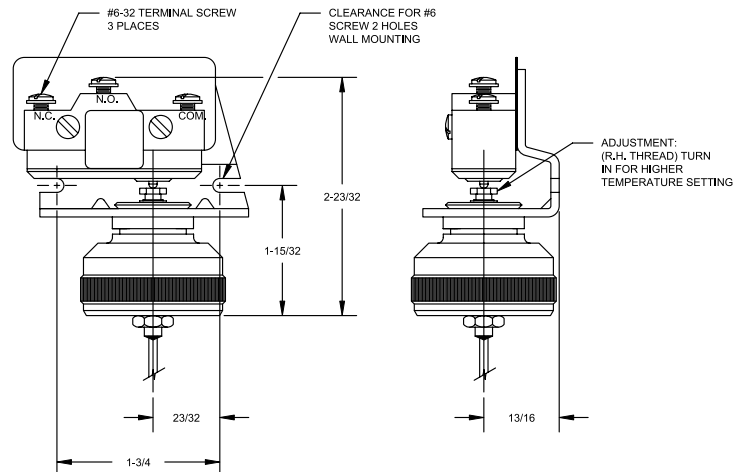

RECOMMENDED PRACTICES AND WARNINGS

United Electric Controls Company recommends careful consideration of the following factors when specifying and installing UE pressure and temperature units. Before installing a unit, the Installation and Maintenance instructions provided with unit must be read and understood.

- To avoid damaging unit, proof pressure and maximum temperature limits stated in literature and on nameplates must never be exceeded, even by surges in the system. Operation of the unit up to maximum pressure or temperature is acceptable on a limited basis (e.g., start-up, testing) but continuous operation must be restricted to the designated adjustable range. Excessive cycling at maximum pressure or temperature limits could reduce sensor life.
- A back-up unit is necessary for applications where damage to a primary unit could endanger life, limb or property. A high or low limit switch is necessary for applications where a dangerous runaway condition could result.
- The adjustable range must be selected so that incorrect, inadvertent or malicious setting at any range point cannot result in an unsafe system condition.
- Install unit where shock, vibration and ambient temperature fluctuations will not damage unit or affect operation. When applicable, orient unit so that moisture does not enter the enclosure via the electrical connection. When appropriate, this entry point should be sealed to prevent moisture entry.
- Unit must not be altered or modified after shipment. Consult UE if modification is necessary.
- Monitor operation to observe warning signs of possible damage to unit, such as drift in set point or faulty display. Check unit immediately.
- Preventative maintenance and periodic testing is necessary for critical applications where damage could endanger property or personnel.
- Electrical ratings stated in literature and on nameplate must not be exceeded. Overload on a switch can cause damage, even on the first cycle. Wire unit according to local and national electrical codes, using wire size recommended in installation sheet.
- Do not mount unit in ambient temp. exceeding published limits.

LIMITED WARRANTY

Seller warrants that the product hereby purchased is, upon delivery, free from defects in material and workmanship and that any such product which is found to be defective in such workmanship or material will be repaired or replaced by Seller (Ex-works, Factory, Watertown, Massachusetts, INCOTERMS); provided, however, that this warranty applies only to equipment found to be so defective within a period of 24 months from the date of manufacture by the Seller. Seller shall not be obligated under this warranty for alleged defects which examination discloses are due to tampering, misuse, neglect, improper storage, and in any case where products are disassembled by anyone other than authorized Seller's representatives. EXCEPT FOR THE LIMITED WARRANTY OF REPAIR AND REPLACEMENT STATED ABOVE, SELLER DISCLAIMS ALL WARRANTIES WHATSOEVER WITH RESPECT TO THE PRODUCT, INCLUDING ALL IMPLIED WARRANTIES OF MERCHANTABILITY OR FITNESS FOR ANY PARTICULAR PURPOSE.

LIMITATION OF SELLER'S LIABILITY

Seller's liability to Buyer for any loss or claim, including liability incurred in connection with (i) breach of any warranty whatsoever, expressed or implied, (ii) a breach of contract, (iii) a negligent act or acts (or negligent failure to act) committed by Seller, or (iv) an act for which strict liability will be inputted to seller, is limited to the "limited warranty" of repair and/or replacement as so stated in our warranty of product. In no event shall the Seller be liable for any special, indirect, consequential or other damages of a like general nature, including, without limitation, loss of profits or production, or loss or expenses of any nature incurred by the buyer or any third party.

UE specifications subject to change without notice.



UNITED ELECTRIC
CONTROLS

180 Dexter Avenue, P.O. Box 9143
Watertown, MA 02471-9143 USA
Telephone: 617 926-1000 Fax: 617 926-2568
<http://www.ueonline.com>