



800 Series Indicating Temperature Controls

Types 800, T800, 802

Please refer to IMT120 for Explosion Proof Types
820E and 822E



UNITED ELECTRIC
CONTROLS

Installation and Maintenance Instructions

Please read all instructional literature carefully and thoroughly before starting. Refer to the final page for the listing of Recommended Practices, Liabilities and Warranties.

GENERAL

Temperature variations are sensed by a liquid filled sensing bulb which hydraulically transmits motion through a mechanism which rotates the indicating pointer and actuates precision snap-acting switch(es). Control set point(s) are varied by turning the external adjustment knob(s), according to procedures outlined (See Part II - Adjustments). Thermometer type T800 provides temperature indication only with no snap-acting switch.

Part I - Installation

Tools Needed

Screwdriver to secure
customer supplied screws
5/64" Allen Wrench



INSTALL UNIT WHERE SHOCK, VIBRATION AND TEMPERATURE FLUCTUATIONS ARE MINIMAL. DO NOT MOUNT UNIT IN AMBIENT TEMPERATURES EXCEEDING PUBLISHED LIMITS. ORIENT UNIT SO THAT MOISTURE IS PREVENTED FROM ENTERING THE ENCLOSURE.



PREVENTATIVE MAINTENANCE / PERIODIC TESTING (6 MONTHS OR SOONER AS DICTATED BY THE ENVIRONMENT) IS NECESSARY TO ENSURE OPERATION OF THE PRODUCT TO SPECIFICATION. LUBRICATE ALL PIVOT POINTS AND MOVING PARTS, TO PREVENT CORROSION, WITH COMPATIBLE DRY LUBRICANTS OR LIGHT GREASE.

When mounting 800 or 802 type controls, it may be necessary to remove adjustment knob and front cover. The knob is secured with a 5/64" Allen Setscrew. The cover is secured by four screws at the corners.

MOUNTING

The controller may be mounted in any position to either a surface or panel (1/4" thick maximum). Locate it where vibration, shock and ambient temperature fluctuations are minimal. It is recommended that mounting the unit with the conduit connection on the top be avoided.

To Flush Mount

Cut out the panel as shown in Figure 1A. Mount to the panel using the two holes located on the flange of the enclosure.

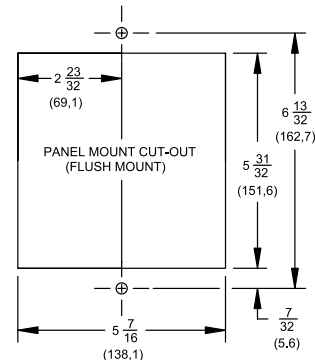

Clearance for #8 screw - (2) places

Figure 1A - Flush Mounting

To Surface Mount

Attach 2 mounting ears found in separate package to recessed areas on back side of enclosure by means of 2 self-tapping screws. Mount to surface per Figure 1B.

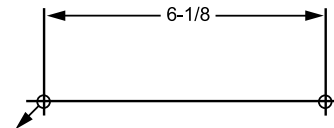

Clearance for #10 screw
- (2) places

Figure 1B - Surface Mounting

Mounting Bulb and Capillary

Fully immerse the bulb and 6" of capillary in the control zone. For best control it is generally desirable to place the bulb close to the heating or cooling source in order to sense temperature fluctuations quickly. Be sure to locate the bulb so it will not be exposed to temperature beyond the instruments range limits.

Try to place any remaining capillary adjacent to the control head so it will sense the same ambient temperatures (control is ambient temperature compensated).

Unless otherwise specified, factory calibration, allows for 6" of capillary tube in the control zone. If longer lengths are required recalibration may be necessary. Follow the procedure outlined in PART II - Adjustments.

Avoid bending or coiling the capillary tube tighter than 1/2" radius. Exercise caution when making bends near the capillary ends.

If a separable well or union connector is used follow separate instructions included with them.

WIRING



DISCONNECT ALL SUPPLY CIRCUITS BEFORE WIRING. ELECTRICAL RATINGS STATED IN LITERATURE AND ON NAMEPLATE SHOULD NEVER BE EXCEEDED. OVERLOAD ON A SWITCH CAN CAUSE FAILURE ON THE FIRST CYCLE. WIRE UNITS ACCORDING TO LOCAL AND NATIONAL ELECTRICAL CODES. MAXIMUM RECOMMENDED WIRE SIZE IS 14 AWG.

Types 800, 802

(Enclosed units)

Connect the electrical conduit to the case securing it with the grounding locknut supplied.

Note: Unless control is connected to a metallic conduit, grounding bushing should be removed from grounding wire. A separate conductor should be provided from grounding system directly to the non-current carrying metal parts of control (splice the grounding wire).

Conduit opening is available on the left side as standard. It can be supplied on the right side on request. Wire through the 7/8" conduit hole directly to the lead-wire(s) provided, color coded as follows, or to the optional terminal block.

	Switch 1	Switch 2
Common	Violet	Yellow
Normally Open	Blue	Orange
Normally Closed	Black	Red

See wiring Diagrams Figure 2A and 2B.

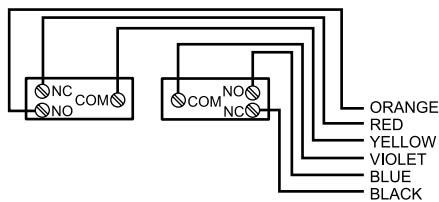

Figure 2A - Dual Switch

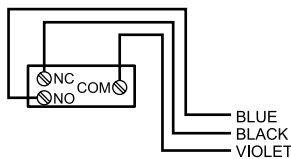

Figure 2B - Single Switch

Optional terminal block wiring is available for single or dual switch controls (option M100). See Figure 2C

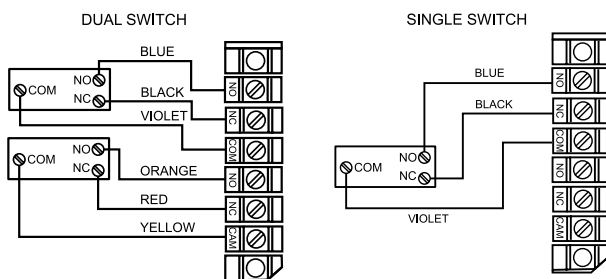

Figure 2C - Terminal Block Option

Part II - Adjustments

Tools Needed

5/64" Allen Wrench
5/16" Open End Wrench (2 required)
Screwdriver

Switch Settings

(Dual switch type only)

The basic enclosed dual switch controller is furnished with individual adjustment of set points as described below.

Type 802 has a separate knob and pointer for each switch. Turn black knob for switch #2 and turn green inserted knob for switch #1. Set points are shown by individual pointers and may be separated up to 100% of dial range apart, so long as the red pointer is set higher than the green pointer.

Replace cover and adjustment knob if removed during installation. Controller is ready for operation. Turn setting pointer to desired control temperature and start up the process. To suit particular process conditions or for greater controller accuracy it may be desirable to make slight alterations to the set point or indicator reading. Procedures for making these adjustments are described below.

Note: Indicating Pointer Deflection:

The indicating pointers will read slightly low when the bulb temperature is 15° above the controller setting. This deflection is normal and repeatable (approximately 0.5% of scale range on single switch models) and is due to the transference of the switching mechanism load to the thermal system. It can be measured by moving the setting pointer from the high to the low end of the scale and observing the resultant indicating pointer deflection.

Note: Prior to making any controller adjustments, the cover and adjustment knobs should be removed. When adjustments are completed, all applicable parts should be replaced.

Note: The adjustment knob slides off adjustment shaft for all controls except the 802. The 802 requires a 5/64" allen wrench. Be sure to replace gasket when re-assembling.

In-Process Adjustments

Use an accurate test thermometer such as a thermocouple with its probe mounted directly to the center of the sensing bulb. Before making any adjustments, allow process temperature to stabilize; i.e., successive on-off cycles repeated.

Correct any difference between the Indicating Pointer and the test thermometer by holding the compensator with a 5/16" wrench while turning the zero adjustment "C" on the thermal assembly with a second 5/16" wrench, per Figure 3 until the brown Indicating Pointer reads the same as the test thermometer. Turning clockwise lowers indicated reading. Compare the process temperature with the set point Adjustment Pointer. Loosen adjustment screw "A" to align set point Adjustment Pointer with the Indicating Pointer. Retighten screw "A".

Adjusting Thermometer Type T800

Use the in-process adjustment to check the control. Differences between the rest instrument and the thermometer can be corrected by turning the zero adjustment "C" per Figure 3 on the thermal assembly. Turning in lowers indicated reading.

Adjusting Single Switch Type 800

Move the set point Adjustment Pointer up scale beyond the black Indicating Pointer. This permits checking the set point by moving the lever arm upward with a finger or tool simulating thermal assembly movement. Connect test lights to indicate switch operation or listen for the switch to click. Loosen adjustment "A" and move the Adjustment Pointer until it agrees with the Indicating Pointer. When the switch clicks re-tighten the screw.

Adjusting Dual Switch Type 802

Connect test lights to indicate switch operation or listen for the individual switch clicks. The separation between switches is the difference between the high and low set points. The set points are determined by setting individual adjustment pointers and may be separated up to 100% of scale range apart.

To align either switch to the Adjustment Pointer the corresponding adjustment "A" must be loosened and the Adjustment Pointer set to the Indicating Pointer, then tighten adjustment "A".

Note: Switch #1, green pointer, cannot be set to operate at a higher setting than switch #2, red pointer.

Correction of Capillary

If the length of capillary immersed in the process differs from the amount immersed at the factory calibration bath, a calibration shift will occur. The error may be corrected as follows:

Move set pointer to the highest temperature setting. Note indicating scale reading with the head and sensor at room temperature. Loosen the two thermal assembly mounting screws. Re-position the housing index against the calibration on the instrument case (or skeleton casting) at a rate of 1 division line per capillary length listed in the following column. Move to the left if capillary is to be added to the process, or to the right if capillary is to be removed from process.

Model Number	Range	Cap Length/Division*
1	-180 to 120°F	2 ft
2	-125 to 350°F	1 1/2 ft
3	-125 to 500°F	1 ft
4	-40 to 120°F	4 ft
5	-40 to 180°F	3 ft
6	0 to 250°F	2 1/2 ft
7	0 to 400°F	2 ft
8	50 to 650°F	2 ft

* Added to or taken away from the process.

Tighten the two thermal assembly mounting screws. Note change indicated scale reading (if any).

Turn zero adjustment "C" to bring indicating pointer reading back to the original reading noted before. Turning in lowers indicated reading.

Note: The thermal assembly can be returned to its original position by aligning its flange with the line scribed on the instrument case.

General Layout

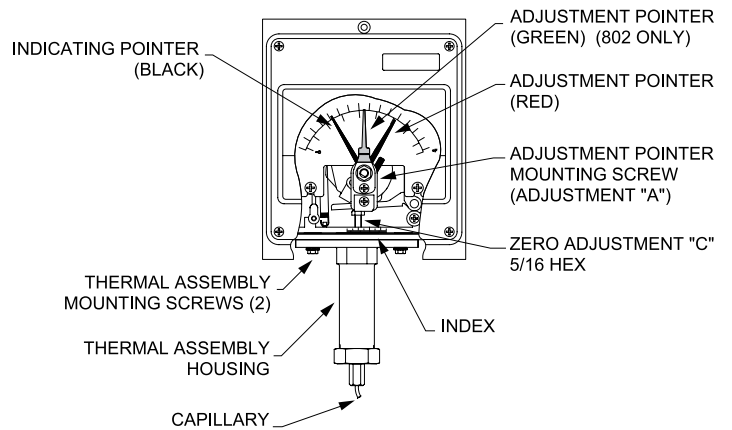

Figure 3

Dimensions

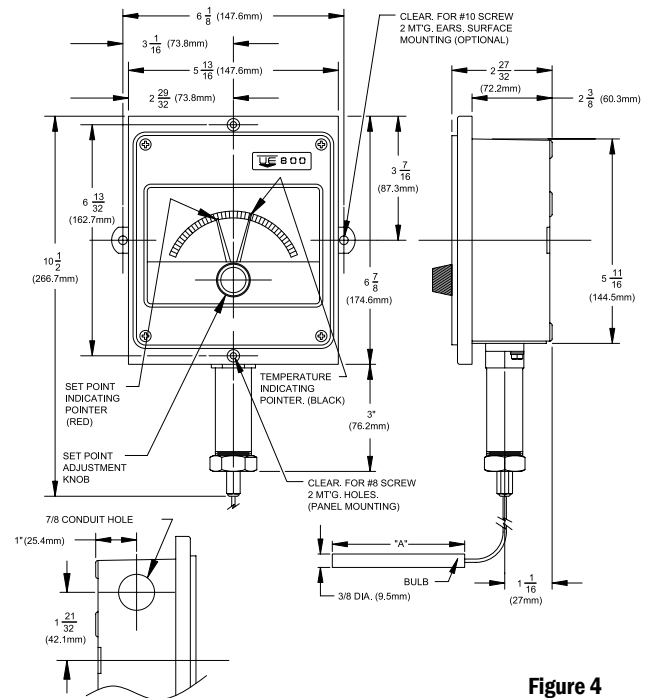

Figure 4

Dimension A

Model	Inches	mm
1BS	3-3/4	95.3
2BS	2-7/16	62.0
3BS	2-1/8	54.0
4BS	6-3/4	171.5
5BS	5	127.0
6BS	4-1/2	114.3
7BS	3	76.2
8BS	3-1/4	82.6

RECOMMENDED PRACTICES AND WARNINGS

United Electric Controls Company recommends careful consideration of the following factors when specifying and installing UE pressure and temperature units. Before installing a unit, the Installation and Maintenance instructions provided with unit must be read and understood.

- To avoid damaging unit, proof pressure and maximum temperature limits stated in literature and on nameplates must never be exceeded, even by surges in the system. Operation of the unit up to maximum pressure or temperature is acceptable on a limited basis (e.g., start-up, testing) but continuous operation must be restricted to the designated adjustable range. Excessive cycling at maximum pressure or temperature limits could reduce sensor life.
- A back-up unit is necessary for applications where damage to a primary unit could endanger life, limb or property. A high or low limit switch is necessary for applications where a dangerous runaway condition could result.
- The adjustable range must be selected so that incorrect, inadvertent or malicious setting at any range point cannot result in an unsafe system condition.
- Install unit where shock, vibration and ambient temperature fluctuations will not damage unit or affect operation. Orient unit so that moisture does not enter the enclosure via the electrical connection. When appropriate, this entry point should be sealed to prevent moisture entry.
- Unit must not be altered or modified after shipment. Consult UE if modification is necessary.
- Monitor operation to observe warning signs of possible damage to unit, such as drift in set point or faulty display. Check unit immediately.
- Preventative maintenance and periodic testing is necessary for critical applications where damage could endanger property or personnel.
- For all applications, a factory set unit should be tested before use.
- Electrical ratings stated in literature and on nameplate must not be exceeded. Overload on a switch can cause damage, even on the first cycle. Wire unit according to local and national electrical codes, using wire size recommended in installation sheet.
- Do not mount unit in ambient temp. exceeding published limits.

LIMITED WARRANTY

Seller warrants that the product hereby purchased is, upon delivery, free from defects in material and workmanship and that any such product which is found to be defective in such workmanship or material will be repaired or replaced by Seller (Ex-works, Factory, Watertown, Massachusetts, INCOTERMS); provided, however, that this warranty applies only to equipment found to be so defective within a period of 24 months from the date of manufacture by the Seller. Seller shall not be obligated under this warranty for alleged defects which examination discloses are due to tampering, misuse, neglect, improper storage, and in any case where products are disassembled by anyone other than authorized Seller's representatives. EXCEPT FOR THE LIMITED WARRANTY OF REPAIR AND REPLACEMENT STATED ABOVE, SELLER DISCLAIMS ALL WARRANTIES WHATSOEVER WITH RESPECT TO THE PRODUCT, INCLUDING ALL IMPLIED WARRANTIES OF MERCHANTABILITY OR FITNESS FOR ANY PARTICULAR PURPOSE.

LIMITATION OF SELLER'S LIABILITY

Seller's liability to Buyer for any loss or claim, including liability incurred in connection with (i) breach of any warranty whatsoever, expressed or implied, (ii) a breach of contract, (iii) a negligent act or acts (or negligent failure to act) committed by Seller, or (iv) an act for which strict liability will be inputed to seller, is limited to the "limited warranty" of repair and/or replacement as so stated in our warranty of product. In no event shall the Seller be liable for any special, indirect, consequential or other damages of a like general nature, including, without limitation, loss of profits or production, or loss or expenses of any nature incurred by the buyer or any third party.

UE specifications subject to change without notice.



UNITED ELECTRIC
CONTROLS

180 Dexter Avenue, P.O. Box 9143
Watertown, MA 02471-9143 USA
Telephone: 617 926-1000 Fax: 617 926-2568
<http://www.ueonline.com>