

PRESSURE, VACUUM AND TEMPERATURE

**FEATURES**

- Compact Size
- Wide Selection of Adjustable Ranges:
Pressure: 30" Hg Vac to 6000 psi (-1 to 413,7 bar)
Temperature: -130 to 650°F (-90 to 343.3°C)
- Choice of One or Two Switch Outputs
- Adjustable or Narrow Deadband Options
- Reference Dial or Hex Screw-Type Setting

OVERVIEW

The 54 Series offers the OEM a combination of reliable performance and low cost. Available in pressure and temperature versions, with single or dual SPDT outputs and enclosed or open frame (skeleton) construction, the 54 Series family provides design versatility.

The 54 has been field-proven in a wide variety of OEM applications, including medical, laboratory, fire protection and heating equipment.

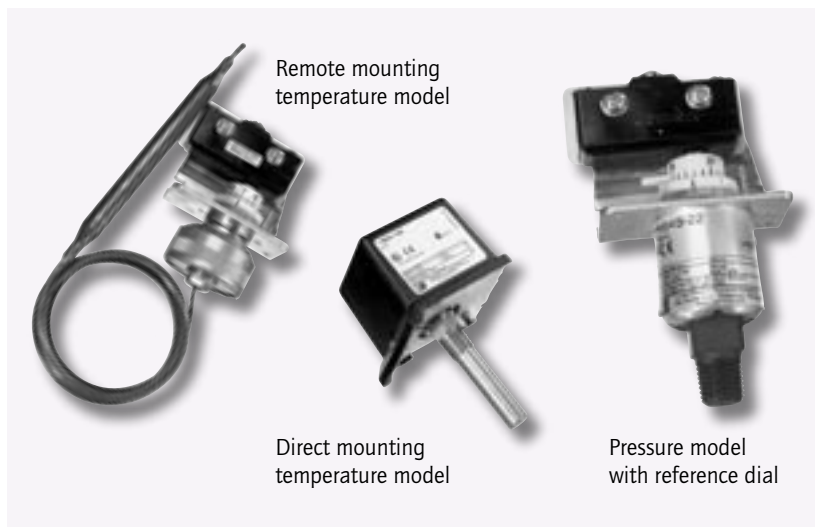

FEATURES

- Compact size
- Choice of one or two switch outputs
- Reference dial or hex screw-type setting
- Optional 1/2" NPT (male) by 1/8" NPT (female) polysulfone® pressure connection
- Optional external manual reset
- NEMA 1 or open frame (skeleton) versions for OEM applications
- Brass bellows models

Polysulfone® is a registered trademark of Amoco

SPECIFICATIONS

STORAGE TEMPERATURE	-65 to 160°F (-54 to 71°C)
AMBIENT TEMPERATURE LIMITS	
Pressure Models	Models 126-164, 610-614: -40 to 160°F (-40 to 71°C); Models 22-28: 0 to 160°F (-18 to 71°C)
Temperature Models	-40 to 160°F (-40 to 71°C). Set point typically shifts less than 1% of range for a 50°F (28°C) ambient temperature change.
SHOCK	Set point repeats after 15 G, 10 millisecond duration
VIBRATION ENCLOSURE	Set point repeats after 2.5 G, 5-500 CPS
CLASSIFICATION	Types C54, C54A, B54, F54, E54, J54, J54A, H54: complies with NEMA 1 requirements. Types C54S, B54S, F54S, E54S, J54S, J54AS, H54S: not applicable
SET POINT REPEATABILITY	
Pressure Models	Models 22-28, 126-164: ± 1% of adjustable range; Models 610-614: ± 1.5% of adjustable range
Temperature Models	± 1% of adjustable range
SWITCH OUTPUT	One or two SPDT snap action switch(es); dual switch may be separated up to 100% of range; switches may be wired "normally open" or "normally closed"
ELECTRICAL RATING	15A 125/250/480 VAC resistive. Electrical switches have limited DC capabilities. Consult UE for additional information.
ENCLOSURE MATERIAL	Lexan® black finish for Types J54, J54A, H54, B54, C54, C54A, E54, F54 only
WEIGHT	Approximately 12 oz.
ELECTRICAL CONNECTION	Types J54 & H54, C54, C54A, B54, E54, F54: 7/8" diameter hole; Type J54A: 1-1/16" diameter hole
PRESSURE CONNECTION	Models 22-28: 1/4" NPT (male); 126-164, 610-614: 1/4" NPT (female)
TEMPERATURE ASSEMBLY	Bulb and Capillary: 6 feet copper or 304 stainless steel capillary Immersion Stem: Brass
TEMPERATURE FILL	Non-toxic oil
TEMPERATURE DEADBAND	Typically 1% of range under laboratory conditions (70°F circulating bath at rate of 1/2°F per minute change)

APPROVALS



UNITED STATES AND CANADA

Type J54, J54A, H54

UL Listed, cUL Certified

Pressure: UL 508, CSA C22.2 No. 14, files # E42272



Type J54S, J54AS, H54S

UL Recognized, cUL Recognized

Pressure: UL 508 CSA C22.2 No. 14, file #E42272



Type B54, C54, E54, F54

UL listed, CSA Certified

Temperature: UL 873, file # E10667;

CSA C22.2 No. 0 & 24, file # LR7814



Type B54S, C54S, E54S, F54S

UL Recognized, CSA Certified

Temperature: UL 873, file # E10667;

CSA C22.2 No. 0 & 24, file # LR7814



EUROPE

Low Voltage Directive (LVD) (73/23/ED & 93/68/EEC)

UEC compliant to LVD

Products rated lower than 50 VAC and 75 VDC are outside of the scope of the LVD

Pressure Equipment Directive (PED) (97/23/EC)

Category IV, Module H1 (Optional - code M407)

TÜV Süddeutschland Bau und Betrieb GmbH (N.B. #0036)

Certificate # USA 02/04/38/001 thru USA 02/07/38/033

PRESSURE MODEL CHART

Model	Adjustable Set Point Range		Deadband		Over Range Pressure*		Proof Pressure**	
	psi (unless noted)	bar (unless noted)	psi (unless noted)	bar (unless noted)	psi	bar	psi	bar
J54, J54A, J54S, J54AS, H54, H54S								
Buna N diaphragm and O-Ring with 1/4" NPT (male) aluminum pressure connection; limited to process temperature below 200°F								
22	30" Hg Vac to 0	-1 to 0	1 to 3.5" Hg Vac	33,9 to 118,5 mbar	0	0	50	3,4
24	3 to 30	0,2 to 2,1	0.4 to 1.3	27,6 to 89,6 mbar	50	3,4	200	13,8
25	10 to 100	0,7 to 6,9	1 to 2.5	68,9 to 172,4 mbar	100 above set point	6,9 above set point	above set point Max 600	above set point Max 41,4
27	30 to 300	2,1 to 20,7	1.3 to 4	89,6 to 275,8 mbar				
28	50 to 500	3,4 to 34,5	1.5 to 5	103,4 to 344,7 mbar				
Brass bellows with nickel-plated brass 1/4" NPT (female) pressure connection; Model 126 has a zinc-plated steel spring exposed to media								
126	30" Hg Vac to 0	-1 to 0	0.2 to 0.9" Hg	6,8 to 30,5 mbar	3	0,2	5	0,3
137	0 to 80 "wc	0 to 199,1 mbar	1 to 8 "wc	2,5 to 19,9 mbar	3	0,2	5	0,3
144	0 to 20	0 to 1,4	0.1 to 0.5	6,9 to 34,5 mbar	20	1,4	25	1,7
146	0 to 30	0 to 2,1	0.1 to 0.6	6,9 to 41,4 mbar	30	2,1	40	2,8
152†	0 to 50	0 to 3,4	0.1 to 0.7	6,9 to 48,3 mbar	50	3,4	75	5,2
156	0 to 100	0 to 6,9	0.2 to 0.8	13,8 to 55,2 mbar	100	6,9	125	8,6
164	0 to 200	0 to 13,8	0.3 to 2	20,7 to 137,9mbar	200	13,8	200	13,8
J54, J54S								
303 stainless steel piston and Buna N O-Ring with 1/4" NPT (female) pressure connection (not recommended for gas service since drying of the O-Ring can allow bleeding of the medium into the atmosphere)								
610	75 to 1000	5,2 to 68,9	30 to 150	2,1 to 10,3	6000	413,7	10,000	689,5
612	125 to 3000	8,6 to 206,8	40 to 250	2,8 to 17,2	6000	413,7	10,000	689,5
614	700 to 6000	48,3 to 413,7	50 to 400	3,4 to 27,6	6000	413,7	10,000	689,5

***Over Range Pressure:** The Maximum pressure that may be applied continuously without causing damage and maintaining set point repeatability.

****Proof Pressure:** The maximum pressure to which a pressure sensor may be occasionally subjected, which causes no permanent damage. The unit may require calibration (e.g., start-up, testing).

† Model not available for types H54, H54S

TEMPERATURE MODEL CHART

Model	Adjustable Set Point Range		Max. Temperature		Scale*** Division		Stem Size
	°F	°C	°F	°C	°F	°C	NPT x BT (inches)
B54, B54S, C54, C54S, C54A, C54AS , Brass immersion stem							
103	0 to 225	-17.8 to 107.2	250	121.1	10	5	3/8 x 2-1/8
109	200 to 425	93.3 to 218.3	425	218.3	10	5	3/8 x 2-1/8
							OD x Length
E54, F54 , Copper bulb and capillary							
D20BC	-130 to 120	-90 to 48.9	170	76.7	10	5	3/8 x 4-1/2
D21BC	0 to 150	-17.8 to 65.6	200	93.3	5	5	3/8 x 6-7/8
D22BC	50 to 300	10 to 148.9	350	176.7	10	5	3/8 x 4-1/2
D23BC	150 to 650	65.6 to 343.3	700	371.1	25	10	3/8 x 3-5/8
E54, F54 , Stainless steel bulb and capillary							
D20BS†	-130 to 120	-90 to 48.9	170	76.7	10	5	3/8 x 4-1/2
D21BS	0 to 150	-17.8 to 65.6	200	93.3	5	5	3/8 x 6-7/8
D22BS	50 to 300	10 to 148.9	350	176.7	10	5	3/8 x 4-1/2
D23BS	150 to 650	65.6 to 343.3	700	371.1	25	10	3/8 x 3-5/8
E54S, F54S , Copper bulb and capillary							
D21BC	0 to 150	-17.8 to 65.6	200	93.3	5	5	3/8 x 6-7/8
D22BC	50 to 300	10 to 148.9	350	176.7	10	5	3/8 x 4-1/2
D23BC	150 to 650	65.6 to 343.3	700	371.1	25	10	3/8 x 3-5/8
E54S, F54S , Stainless steel bulb and capillary							
D21BS	0 to 150	-17.8 to 65.6	200	93.3	5	5	3/8 x 6-7/8
D22BS	50 to 300	10 to 148.9	350	176.7	10	5	3/8 x 4-1/2
D23BS	150 to 650	65.6 to 343.3	700	371.1	25	10	3/8 x 3-5/8

† Not available Type F54

*** Applies to Types B54, B54S, E54, E54S only



HOW TO ORDER

BUILDING A PART NUMBER

Select a **Type**

Refer to the "Type" section below.

Determine type number based on switch output, enclosure, adjustment and reference.

Fill in the type portion of your part number with the corresponding number.

Select a **Model**

Refer to the "Model Charts."

Determine model based on adjustable range, deadband and proof pressure.

Fill in the model portion of your part number with the corresponding number.

Select an **Option**

Refer to the "Options" section.

Determine option number based on switch output, optional materials or other product enhancements.

Fill in the option portion of your part number with the corresponding number.

Leave "option" portion blank if no options are needed. FOR MULTIPLE OPTIONS: Call United Electric Controls.

TYPE

J54:

J54A:

J54S:

J54AS:

H54:

H54S:

DESCRIPTION - PRESSURE MODELS

NEMA 1 enclosure; One SPDT output; internal hex adjustment with no reference dial

NEMA 1 enclosure; Two SPDT outputs; internal hex adjustment with no reference dial

Skeleton construction; One SPDT output; hex adjustment with no reference dial

Skeleton construction; Two SPDT outputs; hex adjustment with no reference dial

NEMA 1 enclosure; One SPDT output; internal adjustment with reference dial

Skeleton construction; One SPDT output; adjustment with reference dial

TEMPERATURE MODELS

C54:

C54A:

C54S:

C54AS:

B54:

B54S:

F54:

F54S:

E54:

E54S:

NEMA 1 enclosure; Immersion stem; one SPDT output; internal hex adjustment with no reference dial

NEMA 1 enclosure; Immersion stem; two SPDT outputs; internal hex adjustment with no reference dial

Skeleton construction; Immersion stem; one SPDT output; hex adjustment with no reference dial

Skeleton construction; Two SPDT outputs; hex adjustment with no reference dial

NEMA 1 enclosure; Immersion stem; one SPDT output; internal adjustment with reference dial

Skeleton construction; Immersion stem; one SPDT output; adjustment with reference dial

NEMA 1 enclosure; Bulb and capillary; one SPDT output; internal hex adjustment with no reference dial

Skeleton construction; Bulb and capillary; one SPDT output; hex adjustment with no reference dial

NEMA 1 enclosure; Bulb and capillary; one SPDT output; internal adjustment with reference dial

Skeleton construction; Bulb and capillary; one SPDT output; adjustment with reference dial

SWITCH OPTIONS*

CODE

0500

1520

1530

2000

DESCRIPTION

Close deadband, 5A 125/250 VAC resistive NOT AVAILABLE ON B54, B54S, C54, C54S, C54A, C54AS, E54S, F54, F54S

Adjustable deadband, 15A 125/250/277 VAC resistive. Adjustable wheel changes rise setting only. If adjustment of fall setting is required, use primary adjustment. NOT AVAILABLE ON TYPES J54A, J54AS, H54, H54S, PRESSURE MODELS 610-614 & TEMPERATURE VERSIONS

External manual reset, 15A 125/250/480 VAC resistive; reset on increasing pressure or temperature only. NOT AVAILABLE ON TYPES J54A, J54S, J54AS, H54S, B54S, C54A, C54AS, C54S, E54S, F54S OR MODELS 610-614

20A 125/250 VAC resistive

* All switches have limited DC capabilities. Consult factory for details.

GENERAL OPTIONS

CODE	DESCRIPTION
M201	Factory set one switch; specify increasing or decreasing pressure or temperature and set point. NOT AVAILABLE ON TYPES J54, J54AS, C54A, C54AS
M202	Factory set two switches; specify increasing or decreasing pressure or temperature and set point. NOT AVAILABLE ON TYPES J54, J54S, H54, H54S, B54, B54S, C54, C54S, E54, E54S, F54, F54S
M270	Calibrated dial in Celsius. NOT AVAILABLE ON PRESSURE VERSIONS AND TYPES B54, B54S, C54, C54S, C54A, C54AS, F54, F54S
M277	Range indicated on nameplate in kPa or MPa. NOT AVAILABLE ON TEMPERATURE VERSIONS
M278	Range indicated on nameplate in kg/cm ² . NOT AVAILABLE ON TEMPERATURE VERSIONS.
M407	CE Compliance to Pressure Equipment directive (category IV). NOT AVAILABLE ON MODELS 22, 126, 137 OR TEMPERATURE VERSIONS
M444	Paper ID tag
M446	Stainless steel ID tag & wire attachment
M540	Viton® construction (deadband and low end range may increase slightly. Consult factory); Wetted parts include Viton® diaphragm and O-Ring plus standard connection material. NOT AVAILABLE MODELS 126-164 OR TEMPERATURE VERSIONS

PRESSURE CONNECTION OPTIONS

M501	Polysulfone® pressure connection 1/2" NPT (male) x 1/8" NPT (female). NOT AVAILABLE MODELS 126-164, 610-614 OR TEMPERATURE VERSIONS
------	---

OPTIONS FOR TEMPERATURE MODELS**UNION CONNECTORS**

For all bulb & capillary switches

Option	Replacement Number	Description
	<u>Brass</u>	
W027	SD6213-27	1/2" NPT w/ 3/4" bushing
W045	SD6213-45	3/4" NPT
W051	SD6213-51	1/2" NPT
	<u>304 Stainless Steel</u>	
W028	SD6213-28	1/2" NPT w/ 3/4" bushing
W046	SD6213-46	3/4" NPT
W050	SD6213-50	1/2" NPT

THERMOWELLS

For all bulb & capillary switches

	<u>Brass</u>	
W075	SD6225-75	3/4" bushing adapter, 4" BT
W191	SD6225-191	1/2" NPT, 4" BT
W118	SD6225-118	3/4" bushing adapter, 7" BT
W192	SD6225-192	1/2" NPT, 7" BT
	<u>316 Stainless Steel</u>	
W076	SD6225-76	3/4" NPT, 4.5" BT
W193	SD6225-193	1/2" NPT, 4.5" BT
W119	SD6225-119	3/4" NPT, 7.5" BT
W177	SD6225-177	1/2" NPT, 7.5" BT
	<i>For all Immersion stem switches</i>	
W141	SD6225-141	1/2" NPT x 1 9/16" BT, brass
W146	SD6225-146	1/2" NPT x 1 9/16" BT, 316 stainless steel

OPTIONAL LENGTHS:

Optional immersion stem lengths to 15" available in brass, with or without 316 st/st thermowell. Consult UE for additional information. Optional capillary length to *50' available in copper or 304 st/st. Armor or Teflon® capillary protection available to lengths less than or equal to capillary length. Consult UE for additional information.

**Consult UE regarding repeatability and ambient effects on capillary lengths over 30'.*

Viton® is a registered trademark of Dupont Dow Elastomers



DIMENSIONAL DRAWINGS

Pressure Models

Type H54, J54 and J54A Models 22 - 28

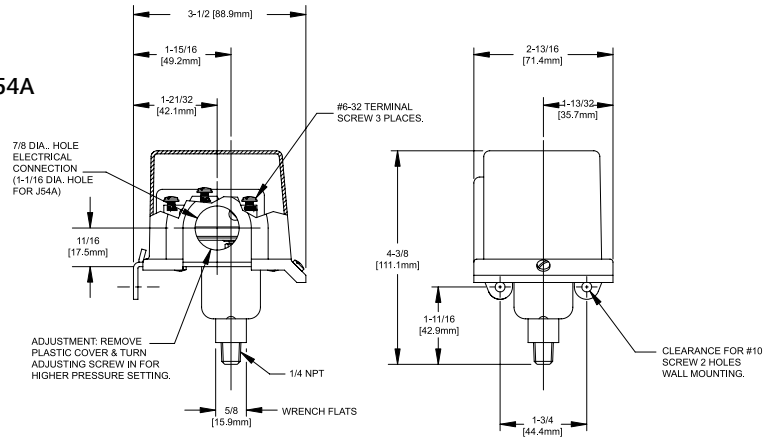

Type J54S, Models 22 - 28

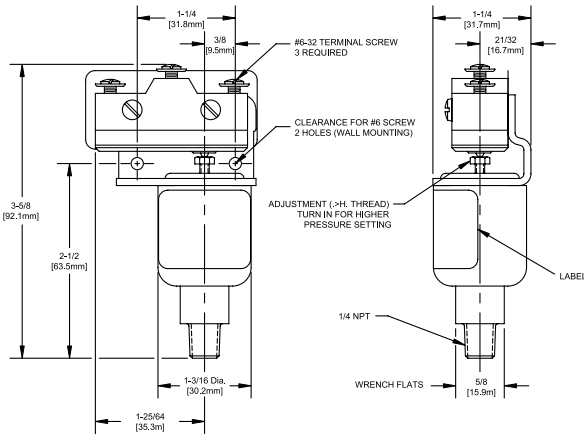

Type J54AS, Models 22 - 28

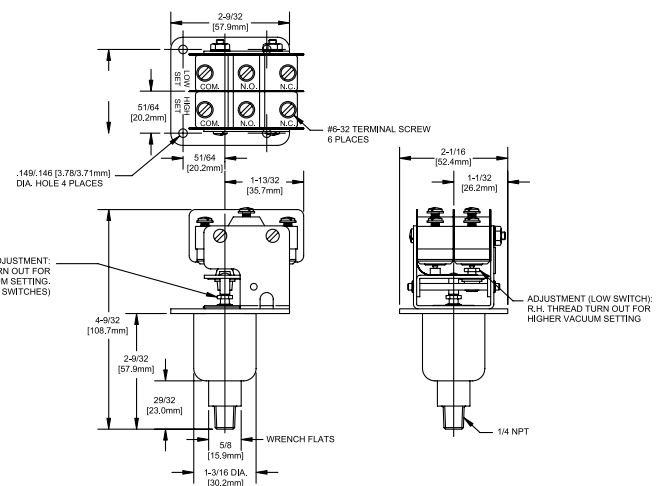

Type H54S, Models 22 - 28

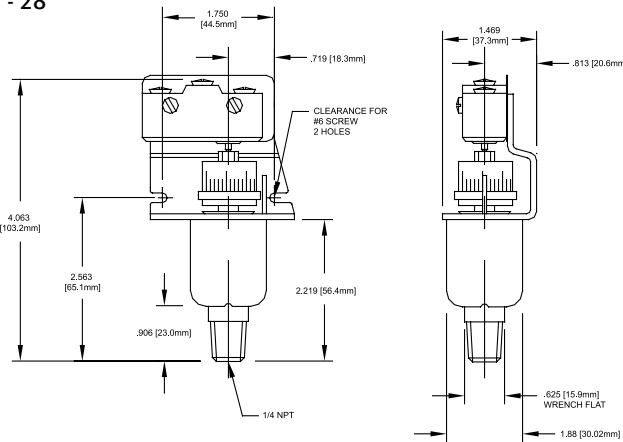

Type H54, J54, and J54A Models 126-164

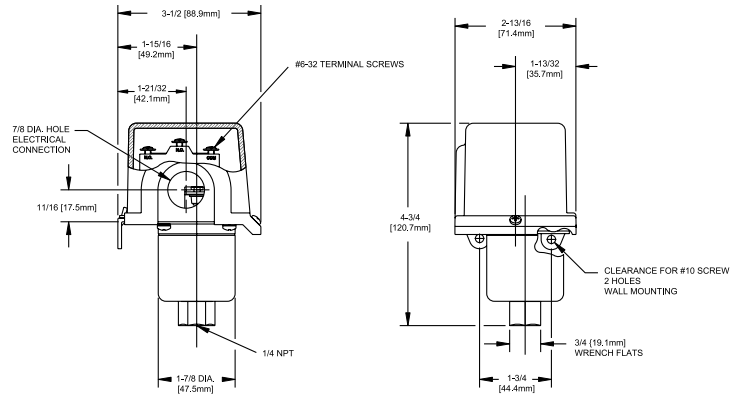

Type J54 Models 610 - 614

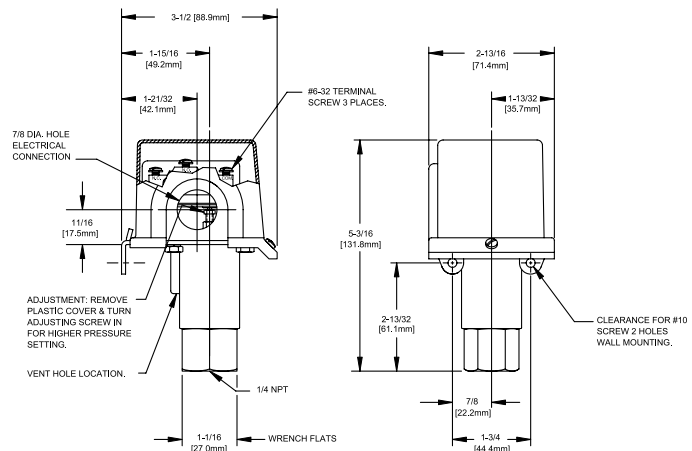

Type J54S Models 610 - 614

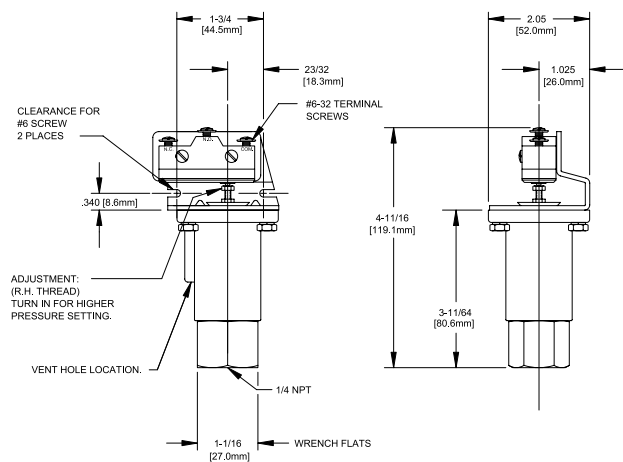



DIMENSIONAL DRAWINGS

Temperature Models

Types B54, C54

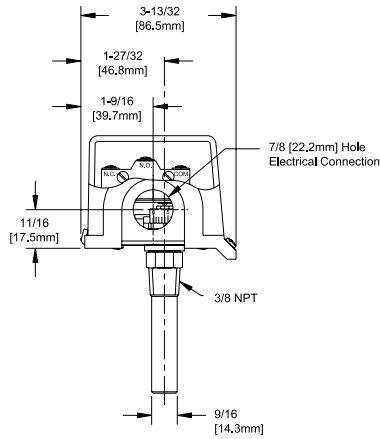

Type C54A

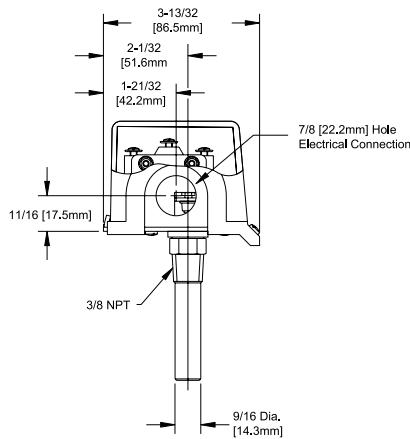

Types B54, C54, C54A

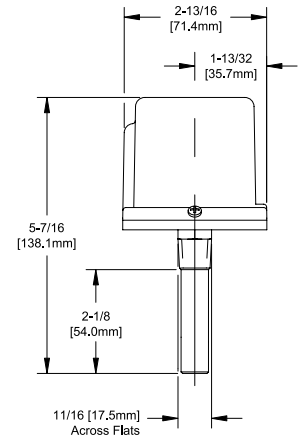

Type B54S

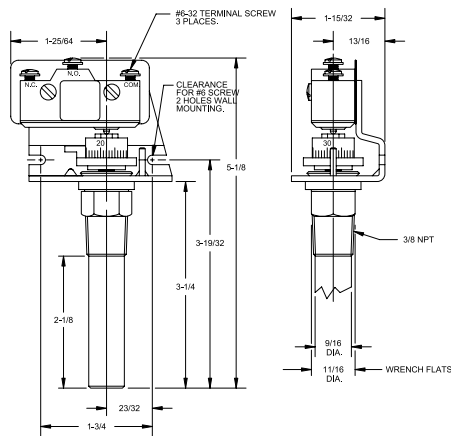

Type C54S

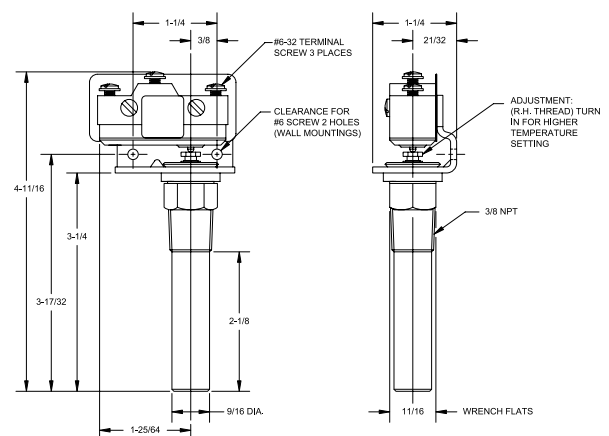

Type C54AS

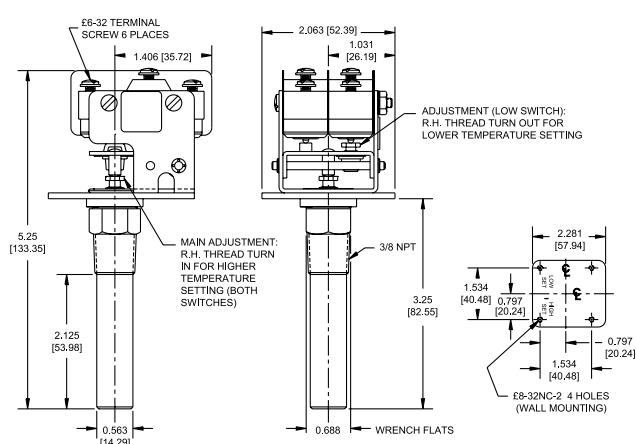

All dimensions stated in inches (millimeters)

Types E54 and F54

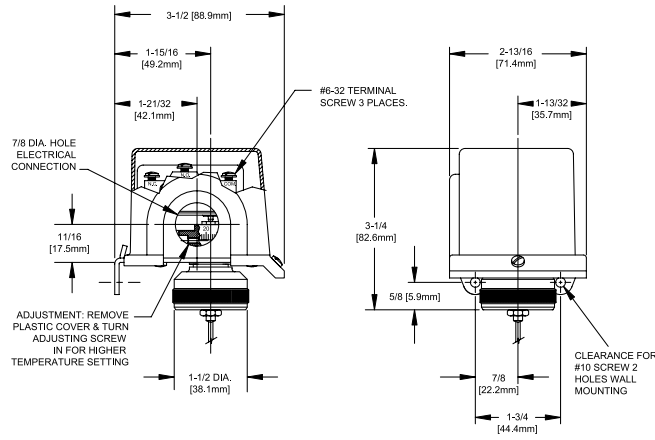

Type F54S

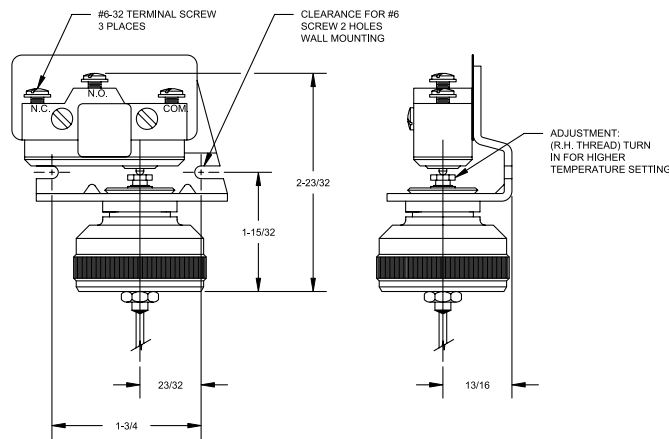

Type E54S

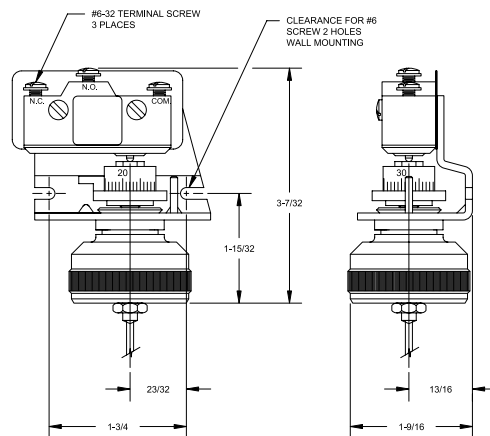

RECOMMENDED PRACTICES AND WARNINGS

United Electric Controls Company recommends careful consideration of the following factors when specifying and installing UE pressure and temperature units. Before installing a unit, the Installation and Maintenance instructions provided with unit must be read and understood.

- To avoid damaging unit, proof pressure and maximum temperature limits stated in literature and on nameplates must never be exceeded, even by surges in the system. Operation of the unit up to maximum pressure or temperature is acceptable on a limited basis (e.g., start-up, testing) but continuous operation must be restricted to the designated adjustable range. Excessive cycling at maximum pressure or temperature limits could reduce sensor life.
- A back-up unit is necessary for applications where damage to a primary unit could endanger life, limb or property. A high or low limit switch is necessary for applications where a dangerous runaway condition could result.
- The adjustable range must be selected so that incorrect, inadvertent or malicious setting at any range point cannot result in an unsafe system condition.
- Install unit where shock, vibration and ambient temperature fluctuations will not damage unit or affect operation. When applicable, orient unit so that moisture does not enter the enclosure via the electrical connection. When appropriate, this entry point should be sealed to prevent moisture entry.
- Unit must not be altered or modified after shipment. Consult UE if modification is necessary.
- Monitor operation to observe warning signs of possible damage to unit, such as drift in set point or faulty display. Check unit immediately.
- Preventative maintenance and periodic testing is necessary for critical applications where damage could endanger property or personnel.
- Electrical ratings stated in literature and on nameplate must not be exceeded. Overload on a switch can cause damage, even on the first cycle. Wire unit according to local and national electrical codes, using wire size recommended in installation sheet.
- Do not mount unit in ambient temp. exceeding published limits.

LIMITED WARRANTY

Seller warrants that the product hereby purchased is, upon delivery, free from defects in material and workmanship and that any such product which is found to be defective in such workmanship or material will be repaired or replaced by Seller (Ex-works, Factory, Watertown, Massachusetts. INCOTERMS); provided, however, that this warranty applies only to equipment found to be so defective within a period of 24 months from the date of manufacture by the Seller. Seller shall not be obligated under this warranty for alleged defects which examination discloses are due to tampering, misuse, neglect, improper storage, and in any case where products are disassembled by anyone other than authorized Seller's representatives. EXCEPT FOR THE LIMITED WARRANTY OF REPAIR AND REPLACEMENT STATED ABOVE, SELLER DISCLAIMS ALL WARRANTIES WHATSOEVER WITH RESPECT TO THE PRODUCT, INCLUDING ALL IMPLIED WARRANTIES OF MERCHANTABILITY OR FITNESS FOR ANY PARTICULAR PURPOSE.

LIMITATION OF SELLER'S LIABILITY

Seller's liability to Buyer for any loss or claim, including liability incurred in connection with (i) breach of any warranty whatsoever, expressed or implied, (ii) a breach of contract, (iii) a negligent act or acts (or negligent failure to act) committed by Seller, or (iv) an act for which strict liability will be inputted to seller, is limited to the "limited warranty" of repair and/or replacement as so stated in our warranty of product. In no event shall the Seller be liable for any special, indirect, consequential or other damages of a like general nature, including, without limitation, loss of profits or production, or loss or expenses of any nature incurred by the buyer or any third party.

UE specifications subject to change without notice.

U.S. SALES OFFICES

United Electric Controls
32 Highland Rd.
South Hampton, NH 03827
Phone: 603-394-0078
FAX: 603-394-0175

United Electric Controls
28 N. Wise Ave.
Freeport, IL 61032
Phone: 815-235-3501
FAX: 815-235-3847

United Electric Controls
1022 Vineyard Drive
Conyers, GA 30013
Phone: 770-483-8400
FAX: 770-929-8716

United Electric Controls
5829 Grazing Court
Mason, OH 45040
Phone: 513-398-3175
FAX: 513-398-3076

United Electric Controls
102 Salazar Court
Clayton, CA 94517
Phone: 925-524-0210
FAX: 925-524-0210

United Electric Controls
27 Summit Terrace
Sparta, NJ 07871
Phone: 973-271-2550
FAX: 973-729-6099

United Electric Controls
4306 Whickham Drive
Fulshear, TX 77441
Phone: 832-457-6138
FAX: 832-201-8116

CANADA

EASTERN
68 Mosley Crescent
Brampton, Ontario
Canada L6Y 5C8
Phone: 905-455-5131
FAX: 905-455-5131

WESTERN
148 Silver Ridge Close N.W.
Calgary, Alberta
Canada T3B 3T4
Phone: 403-247-3724
FAX: 403-247-3724

INTERNATIONAL OFFICES

BELGIUM
United Electric Controls-Europe
G. Van Gervenstraat 19A
B-9120 Beveren-Waas, Belgium
Phone: 32-37554-383
FAX: 32-37552-747

CHINA
United Electric Controls
Room 1114, No. 511
Shenshi Building
Weihai Road
Shanghai 200041, P.R. China
Phone: +8621-6255 8059
FAX: +8621-6255 8349

EASTERN EUROPE & SCANDINAVIA
United Electric Controls
05-806 Komorow
Kujawska 5, Poland
Phone: +48 22 499 4804
FAX: +48 22 499 4803

GERMANY
United Electric Controls
An Der Zentlinde 21
D-64711 Erbach, Germany
Phone: 496-062-7400
FAX: 496-062-7501

MALAYSIA
United Electric Controls, Far East
No. 1-2-2, 2nd Floor
Jalan 4/101C
Cheras Business Centre
Batu 5, Jalan Cheras
56100 Kuala Lumpur, Malaysia
Phone: 603-9133-4122
FAX: 603-9133-4155

MEXICO
United Electric Controls
Andador Austria 102
Fracc. Petroquimica CP 89365
Tampico, Tamaulipas Mexico
Phone: 833-132-3726
FAX: 833-132-3726

RUSSIA
United Electric Controls, Moscow
Kuusinena str., 19A, Office 310
Moscow, 125252, Russia
Phone: +7 (095) 792-88-06
FAX: +7 (095) 258-92-12



UNITED ELECTRIC
CONTROLS

180 Dexter Avenue, P.O. Box 9143
Watertown, MA 02471-9143 USA
Telephone: 617 926-1000 Fax: 617 926-2568
<http://www.ueonline.com>