

## SITRANS F M MAGFLO®

Electromagnetic flowmeter

type MAG 1100, DN 2 - DN 100

083R9017

083R9017

## Introduction

Siemens Flow Instruments SITRANS F M MAGFLO® electromagnetic flowmeters consist of a sensor and a transmitter. These instructions only describe the sensor installation. For further information on the transmitter installation, please refer to the SITRANS F M MAGFLO® handbook.

Technical Documentation (handbooks, instructions, manuals etc.) on the complete product range SITRANS F can be found on the internet/intranet on the following links:

English: <http://www4.ad.siemens.de/WW/view/en/10806951/133300>

## Dimensions and weight

## MAG 1100/6000 and MAG 1100/5000, compact/separate

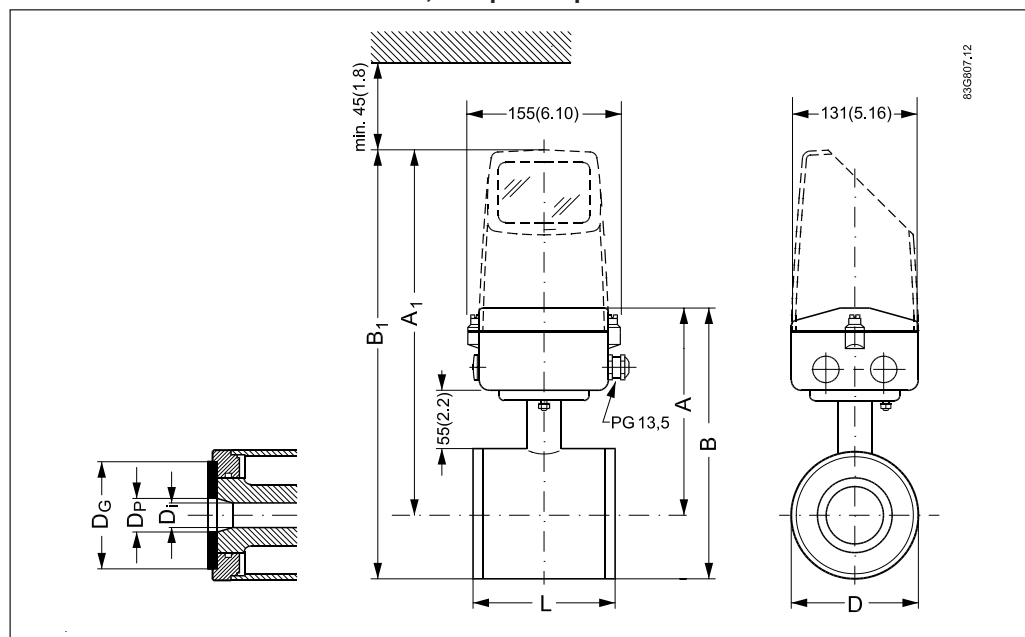

DN	A <sup>1)</sup> [mm]	B <sup>1)</sup> [mm]	A <sub>1</sub> [mm]	B <sub>1</sub> [mm]	D [mm]	D <sub>i</sub> <sup>2)</sup> [mm]	D <sub>i</sub> (PFA) [mm]	D <sub>p</sub> [mm]	D <sub>G</sub> [mm]	Weight <sup>3)</sup> [kg]
2	161	186	314	339	48.3	2	N/A	17.3	34	2.2
3	161	186	314	339	48.3	3	N/A	17.3	34	2.2
6	161	186	314	339	48.3	6	N/A	17.3	34	2.2
10	161	186	314	339	48.3	10	10	13.6	34	2.2
15	161	186	314	339	48.3	15	16	17.3	40	2.2
25	169	201	322	354	63.4	25	26	28.5	56	2.7
40	181	223	334	376	84.0	40	38	43.4	75	3.4
50	189	240	342	393	101.6	50	50	54.5	90	4.2
65	199	259	352	412	120.0	65	66	68.0	112	5.5
80	205	271	358	424	133.0	80	81	82.5	124	7.0
100	218	297	371	450	159.0	100	100	107.1	145	10.0

Size	A <sup>1)</sup> [inch]	B <sup>1)</sup> [inch]	A <sub>1</sub> [inch]	B <sub>1</sub> [inch]	D [inch]	D <sub>i</sub> <sup>2)</sup> [inch]	D <sub>i</sub> (PFA) [inch]	D <sub>p</sub> [inch]	D <sub>G</sub> [inch]	Weight <sup>3)</sup> [lbs]
1/12"	6.34	7.33	12.36	13.35	1.90	0.24	N/A	0.68	1.34	4.8
1/8"	6.34	7.33	12.36	13.35	1.90	0.24	N/A	0.68	1.34	4.8
1/4"	6.34	7.33	12.36	13.35	1.90	0.24	N/A	0.68	1.34	4.8
3/8"	6.34	7.33	12.36	13.35	1.90	0.39	0.39	0.53	1.34	4.8
1/2"	6.34	7.33	12.36	13.35	1.90	0.59	0.63	0.68	1.57	4.8
1"	6.66	7.92	12.68	13.94	2.50	0.98	1.02	1.12	2.20	4.9
1 1/2"	7.13	8.78	13.15	14.81	3.31	1.57	1.50	1.71	2.95	7.5
2"	7.44	9.45	13.47	15.47	4.00	1.97	1.97	2.15	3.54	9.2
2 1/2"	7.84	10.20	13.86	16.22	4.72	2.56	2.60	2.68	4.41	12.0
3"	8.07	10.67	14.10	16.70	5.24	3.15	3.19	3.25	4.88	15.0
4"	8.59	11.70	14.61	17.72	6.26	3.94	3.94	4.22	5.91	22.0

1) 13 mm/0.5" shorter when the AISI terminal box is used. (high temperature 200°C (390°F)).

2) DN 2-3 Zirconium (ZrO<sub>2</sub>), DN 6-100/1/4"-4" Ceramic (Al<sub>2</sub>O<sub>3</sub>).

3) With transmitter MAG 5000 or MAG 6000 installed, weight is increased by approximately 0.8 kg (1.8 lb).

**Dimensions and weight**  
(continued)

The MAG 1100 sensor can also be used with the MAG 6000 Industry (Ex d) transmitter.

The total build-in length "L" [mm] depends on the gasket selected.

Size		EPDM		Graphite		PTFE (Teflon)		Without gasket		Earthing ring	
DN	Inch	[mm]	[inch]	[mm]	[inch]	[mm]	[inch]	[mm]	[inch]	[mm]	[inch]
2	1/12	64	2.52	66	2.60	70	2.75	64	2.52	77	3.03
3	1/8	64	2.52	66	2.60	70	2.75	64	2.52	77	3.03
6	1/4	64	2.52	66	2.60	70	2.75	64	2.52	77	3.03
10	3/8	64	2.52	66	2.60	70	2.75	64	2.52	77	3.03
15	1/2	65	2.56	66	2.60	70	2.75	64	2.52	77	3.03
25	1	80	3.15	81	3.19	85	3.35	79	3.10	92	3.62
40	1 1/2	95	3.74	96	3.78	100	3.94	94	3.70	107	4.21
50	2	105	4.13	106	4.17	110	4.33	104	4.05	117	4.61
65	2 1/2	130	5.12	131	5.15	135	5.31	129	5.05	142	5.60
80	3	155	6.10	156	6.14	160	6.30	154	6.00	167	6.57
100	4	185	7.28	186	7.31	190	7.48	184	7.20	197	7.76

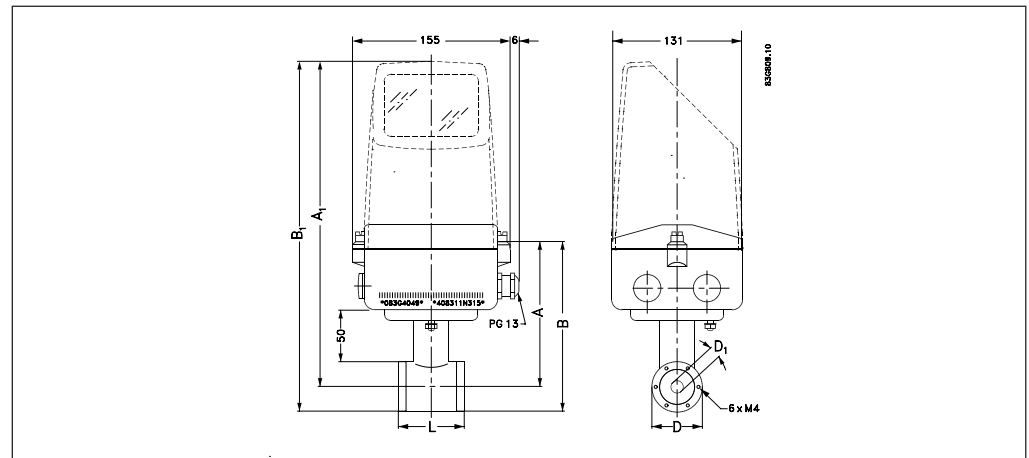

The MAG 1100 DN 2, 3, 6 and DN 10 are prepared for G 1/2" (ISO) or 1/2" NPT pipe connection.

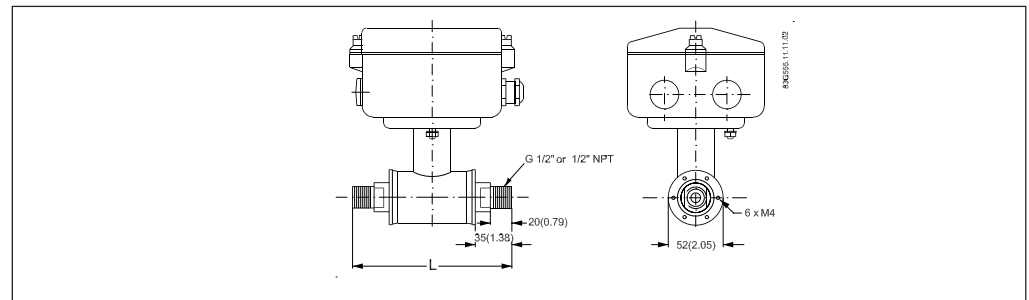

The length "L" varies dependent on the gasket choice:

	Without gasket	EPDM	Graphite	Teflon
L [mm]	150	150	152	156

Installation, general

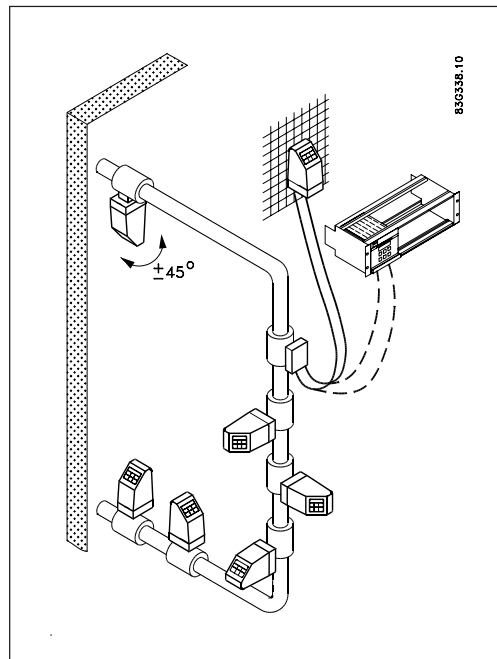

Reading and operating the flowmeter is possible under almost any installation conditions because the display can be oriented in relation to the sensor. To ensure optimum flow measurement attention should be paid to the following:

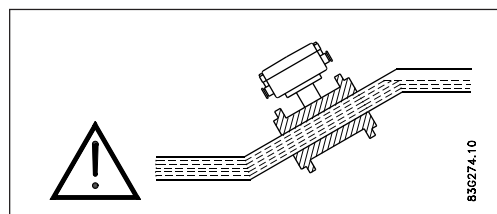

The sensor must always be completely full with liquid.

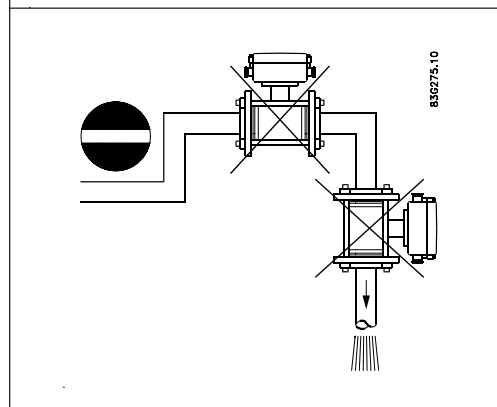

Therefore avoid:

- Installation at the highest point in the pipe system
- Installation in vertical pipes with free outlet

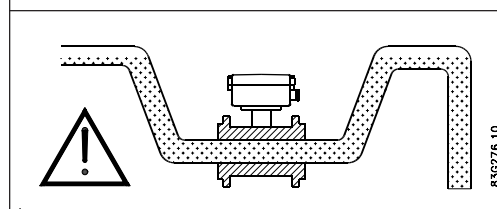

For partially filled pipes or pipes with downward flow and free outlet the flowmeter should be located in a U-tube.

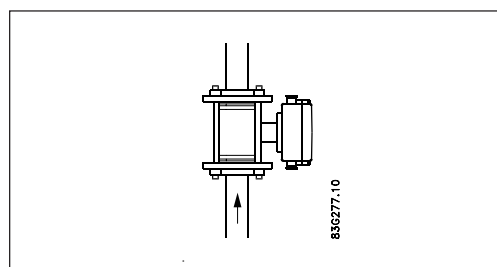

**Installation in vertical pipes**

Recommended flow direction: upwards. This minimizes the effect on the measurement of any gas/air bubbles in the liquid.

**Installation, general**  
(continued)

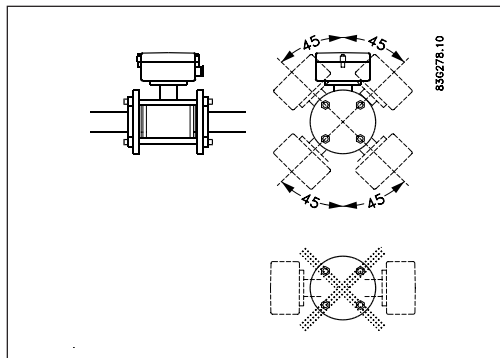

**Installation in horizontal pipes**

The sensor must be mounted as shown in the upper figure. Do not mount the sensor as shown in the lower figure. This will position the electrodes at the top where there is possibility for air bubbles and at the bottom where there is possibility for mud, sludge, sand etc.

If using empty pipe detection the sensor can be tilted 45°, as shown in the upper figure.

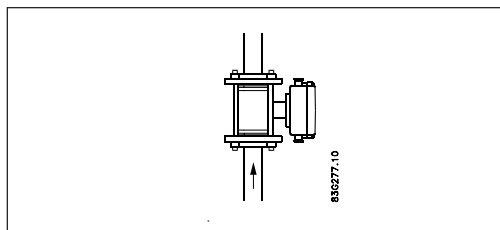

**Measuring abrasive liquids and liquids containing particles**

Recommended installation is in a vertical/inclined pipe to minimize the wear and deposits in the sensor.

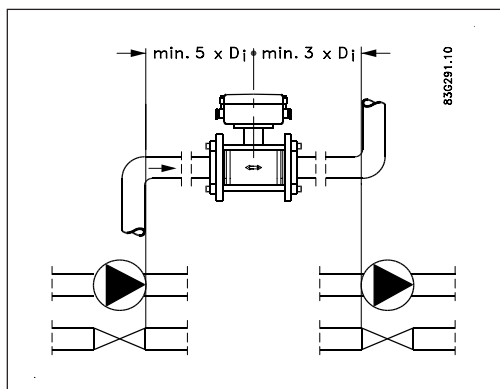

**Inlet and outlet conditions**

To achieve accurate flow measurement it is essential to have straight lengths of inlet and outlet pipes and a certain distance between pumps and valves.

It is also important to centre the flowmeter in relation to pipe flanges and gaskets.

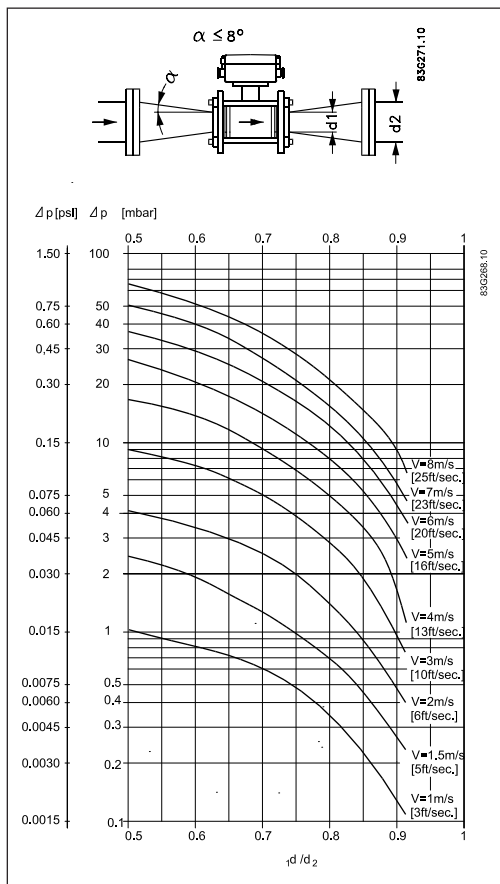

**Installation in large pipes**

The flowmeter can be installed between two reducers (e.g. DIN 28545). Assuming that at 8° the following pressure drop curve applies. The curves are applicable to water.

**Example:**

A flow velocity of 3 m/s (V) in a sensor with a diameter reduction from DN 100 to DN 80 ( $d_1/d_2 = 0.8$ ) gives a pressure drop of 2.9 mbar.

**Installation, general**  
(continued)

**Potential equalization**

To obtain optimum results from the measuring system the sensor's chassis point/housing must have the same electrical potential as the liquid being measured. Depending on the type of gasket selected (graphite, EPDM or PTFE) and application, this can be achieved as follows:

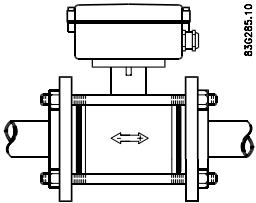
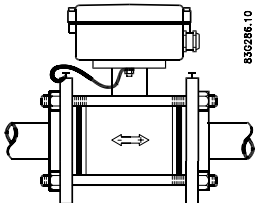
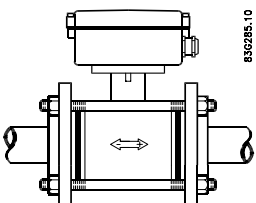
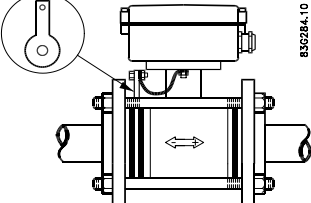
	Graphite gaskets	EPDM or PTFE gaskets
Electrically conductive piping	 <p><b>A:</b> Potential equalization with electrically conductive graphite gaskets</p>	 <p><b>B:</b> Potential equalization using earth strap supplied.</p>
Electrically non-conductive piping	 <p><b>C:</b> Potential equalization with electrically conductive graphite gaskets</p>	 <p><b>D:</b> Potential equalization using separate potential equalization ring</p>

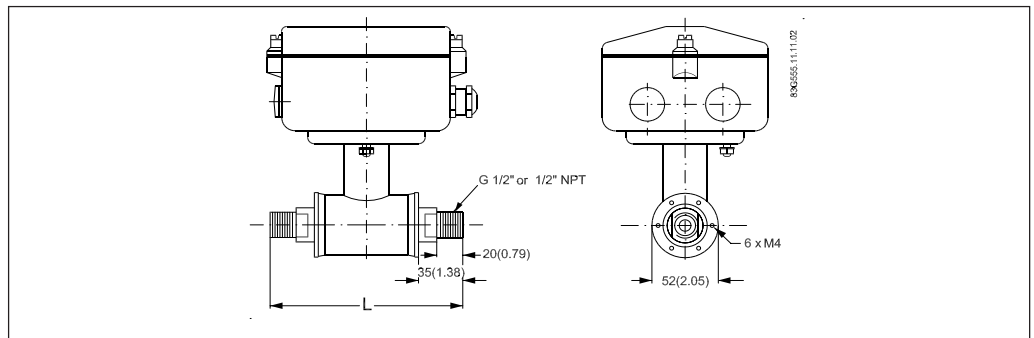

The sensors DN 2, 3, 6 and DN 10 can also be mounted between two adapter flanges. In this way the potential equalization with the liquid occurs automatically.

**NOTE:**

Special attention must be paid to piping systems with cathodic protection. See SITRANS F M MAGFLO® handbook.

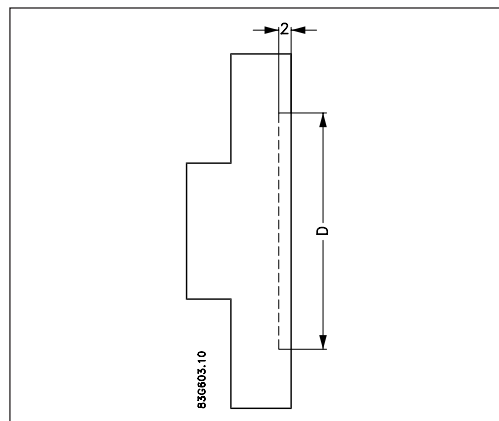

For applications where high accuracy is required, it will be advantageous to use recessed flanges as shown in the drawing.

**NB**

To obtain optimum measuring accuracy and the necessary tightness, it is important that the sensor gaskets and the flange centre lines are merging and that the connection flanges have been mounted at right angles to the pipe. The connection flanges must be parallel.

**Installation**

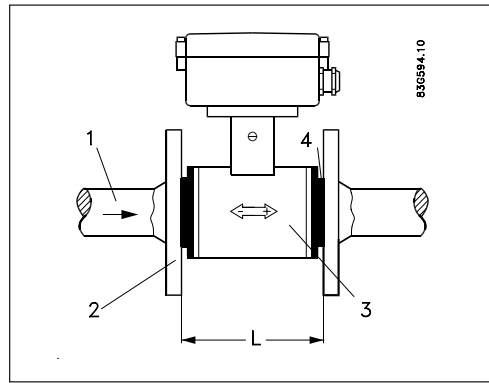

The design of the sensor MAG 1100 allows for bi-directional flow. Dimension L is given in the previous table. The arrow at the sensor indicates recommended flow direction (the meter has been calibrated with flow in arrow direction "+").

- 1. Existing pipe
- 2. Flange
- 3. Sensor
- 4. Gaskets
- L. Sensor length incl. gaskets

**Tightening**

First place three stay-bolts to locate the sensor, see **a**. These should be tightened gently, making sure that each gasket fits exactly into its recess at either end of the sensor, see **b**. The remaining flange bolts can now be inserted and tightened using about 25% of the actual tightening torque, see table d.

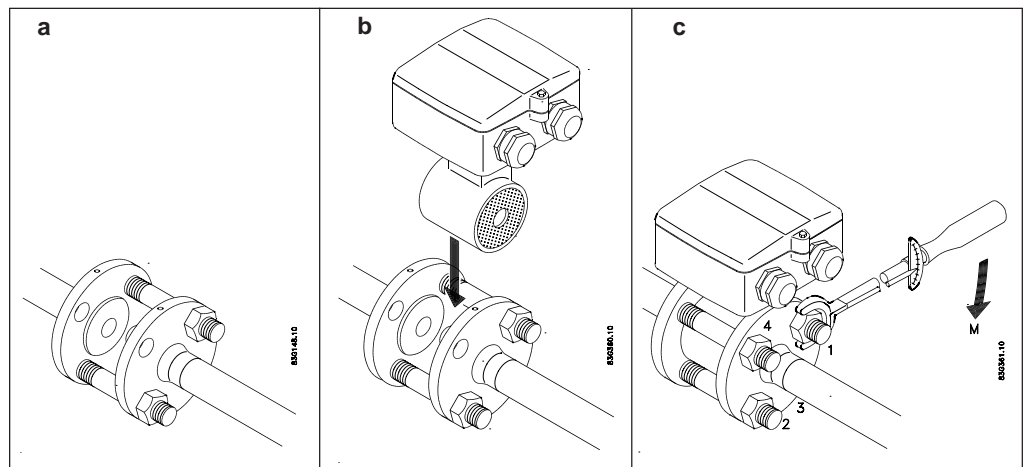

**d**

DN	M <sub>A</sub> [N <sub>m</sub> ]
2	13
3	13
6	13
10	13
15	16
25	30
40	54
50	90
65	90
80	90
100	115

10 Nm ~ 1 kpm

The bolts must be tightened using up to 50% of the max. tightening torque for the pipe dimensions stated. The max. tightening torque for different size pipes is given in the table **d**. The bolts must now be cross-tightened in the sequence shown in **c**, using up to 100% torque.

**Installation of the cover or transmitter on the terminal box**

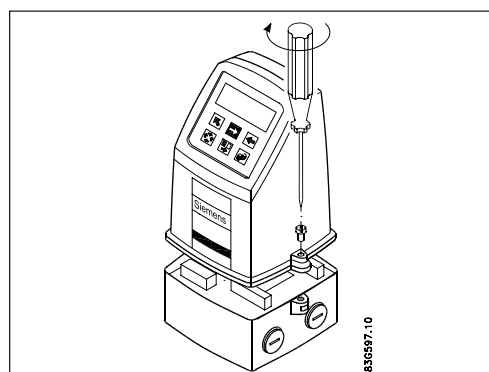

- 1. Mount the cover or the transmitter on the terminal box.
- 2. It is important that the screws are firmly tightened (4 Nm). Use a large screwdriver fitting into the screw slot.