

INSTALLATION AND MAINTENANCE INSTRUCTIONS

2-WAY DIRECT-ACTING SOLENOID VALVES NORMALLY OPEN AND NORMALLY CLOSED OPERATION LEVER ACTUATED — 3/8, 1/2 AND 3/4 NPT — FUEL OIL SERVICE

BULLETIN

8266



FORM NO. V-5987

DESCRIPTION

Bulletin 8266 valves are 2-way, normally open or normally closed lever actuated solenoid valves. Valve bodies are of forged brass construction and may be provided with stainless steel or VITON® resilient seating. The core and the lever/disc sub-assembly are the only moving parts. Valves are offered with or without a bypass feature for normally closed operation. Standard valves have a General Purpose, NEMA Type 1 Solenoid Enclosure. Valves may also be equipped with an enclosure which is designed to meet NEMA Type 4 - Watertight, NEMA Type 7 (C or D) Hazardous Locations, Class I, Groups C or D and NEMA Type 9 (E, F or G) Hazardous Locations - Class II, Groups E, F or G. Installation and Maintenance Instructions for the Explosion-Proof/Watertight Solenoid Enclosure are shown on Form No. V-5381.

OPERATION

Normally Closed: Valve is closed when solenoid is de-energized. Valve opens when solenoid is energized.

Normally Open: Valve is open when solenoid is de-energized. Valve closes when solenoid is energized.

IMPORTANT: No minimum operating pressure differential required.

INSTALLATION

Check nameplate for correct catalog number, pressure, voltage and service.

TEMPERATURE LIMITATIONS

For maximum valve ambient and fluid temperatures, refer to chart below. Check catalog number and watt rating on nameplate to determine the maximum temperatures.

A-C CONSTRUCTION ONLY					
Coil	Catalog Number Prefix	Watts	Coil Class	Maximum Ambient Temp. °F	Maximum Fluid Temp. °F
Standard	None	15.4	A	77	190
	None	20	F	77	225
				95	200
For Higher Fluid and/or Ambient Temp. Use:	FT	15.4	F	95	250
				104	225
	HT	15.4	H	122	250
				122	250
HB	20	H	122	250	
			122	250	

POSITIONING

Valves must be mounted with solenoid vertical and upright above the valve body.

MOUNTING

Two holes (.201 diameter) are provided in the valve body for mounting. Refer to Figure 1.

PIPING

Connect piping to valve according to markings on valve body (flow arrow). Apply pipe compound sparingly to male pipe threads only; if applied to valve threads, it may enter the valve and cause operational difficulty. Pipe strain should be avoided by proper support and alignment of piping. When tightening the pipe, do not use valve as a lever. Wrenches applied to valve body or piping are to be located as close as possible to connection point.

IMPORTANT: For the protection of the solenoid valve, install a strainer or filter suitable for the service involved in the inlet side as close to the valve as possible. Periodic cleaning is required depending on service conditions. See Bulletins 8600, 8601 and 8602 for strainers.

WIRING

Wiring must comply with Local and National Electrical Codes. Solenoid housings are provided with accommodations or connections for 1/2 inch conduit. The general purpose solenoid enclosure may be rotated to facilitate wiring by removing the retaining cap or clip. **CAUTION:** When metal retaining clip disengages, it will spring upward. Rotate enclosure to desired position. Replace retaining cap or clip before operating.

SOLENOID TEMPERATURE

Standard catalog valves are supplied with coils designed for continuous duty service. When the solenoid is energized for a long period, the solenoid enclosure becomes hot and can be touched with the hand only for an instant. This is a safe operating temperature. Any excessive heating will be indicated by the smoke and odor of burning coil insulation.

MAINTENANCE

WARNING: Turn off electrical power supply and line pressure to valve before making repairs. It is necessary to remove the piping from the outlet end of the valve body for repairs.

CLEANING

A periodic cleaning of all solenoid valves is desirable. The time between cleanings will vary depending on medium and service conditions. In general, if the voltage to the coil is correct, sluggish valve operation, excessive noise or leakage will indicate that cleaning is required. Clean valve strainer or filter when cleaning solenoid valve.

PREVENTIVE MAINTENANCE

1. Keep the medium flowing through the valve as free from dirt and foreign material as possible.
2. While in service, operate the valve at least once a month to insure proper opening and closing.
3. Periodic inspection (depending on medium and service conditions) of internal valve parts for damage or excessive wear is recommended. Thoroughly clean all parts. Replace any parts that are worn or damaged.

IMPROPER OPERATION

1. **Faulty Control Circuit:** Check the electrical system by energizing the solenoid. A metallic click signifies the solenoid is operating. Absence of the click indicates loss of power supply. Check for loose or blown-out fuses, open-circuited or grounded coil, broken lead wires or splice connections.
2. **Burned-Out Coil:** Check for open-circuited coil. Replace coil if necessary.
3. **Low Voltage:** Check voltage across coil leads. Voltage must be at least 85% of nameplate rating.
4. **Incorrect Pressure:** Check pressure at solenoid valve. Pressure to the valve must be within the range specified on the nameplate.
5. **Thick Oil:** Check oil viscosity. Some oils may be too thick for the valve to handle if the fluid temperature is decreased and may cause clogging and sticking. Oil viscosity should not be greater than 5,000 SSU.
6. **Excessive Leakage:** Disassemble valve and clean all parts and passageways. Replace worn or damaged parts with a complete Spare Parts Kit for best results.

COIL REPLACEMENT (Refer to Figures 2 & 3.)

Turn off electrical power supply and disconnect coil lead wires. Proceed in the following manner:

1. Remove retaining cap or clip, nameplate and cover. **CAUTION:** When metal retaining clip disengages, it will spring upward.
2. Slip yoke containing coil, sleeves and insulating washers off the solenoid base sub-assembly. Insulating washers (2) are omitted when a molded coil is used.
3. Slip coil, sleeves and insulating washers from yoke.
4. Reassemble in reverse order of disassembly paying careful attention to exploded views provided for identification and placement of parts.

CAUTION: Solenoid must be fully reassembled as the housing and internal parts are part of and complete the magnetic circuit. Place an insulating washer at each end of coil, if required.

VALVE DISASSEMBLY

Depressurize valve and turn off electrical power supply. For normally closed construction, refer to Figure 2. For normally open construction, refer to Figure 3. To determine valve construction, see note under Paragraph 3. Proceed in the following manner:

1. Disassemble valve in an orderly fashion paying careful attention to exploded views provided for identification and placement of parts.
2. Remove retaining cap or clip and slip the entire solenoid enclosure off the solenoid base sub-assembly. **CAUTION:** When metal retaining clip disengages, it will spring upward.
3. Unscrew solenoid base sub-assembly and lift core/spring assembly upward. Remove solenoid base gasket assembly. **NOTE:** At this point, valve construction may be determined. If core assembly has two springs, the valve construction is "Normally Closed" as shown in Figure 2. If core assembly has one spring, valve construction is "Normally Open" as shown in Figure 3.
4. Unscrew union nut and disconnect piping from connector (if necessary) at valve outlet.
5. Remove connector gasket from connector.
6. Holding connector securely, unscrew seat. Remove seat gasket and spacer from connector. **NOTE: If the seat being removed has a notched groove cut into the hex, the "SPACER" will be omitted.**
7. Remove the lever/disc assembly by inserting a stiff piece of wire (or similar tool) with a hooked end into a hole in the disc guide. Pull lever/disc assembly from valve body. The hole for removal in the disc guide will be at the bottom for normally closed construction and at the top for normally open construction.
8. Once the lever/disc assembly is removed, be careful not to allow lever pin to slip from assembly. Disassembly of this part is not required. However, should this part become disengaged, it may be reassembled by following illustrations provided in exploded views.
9. Remove core/spring assembly from valve body. **NOTE:** Upper core spring is only present in normally closed construction.
10. All parts are now accessible for cleaning or replacement. Replace worn or damaged parts with a complete Spare Parts Kit for best results.

*DuPont registered trademark

ASCO Valves



VALVE REASSEMBLY

Reassemble in reverse order of disassembly paying careful attention to exploded and cut-away views provided. Determine valve construction i.e. normally closed or normally open and select the appropriate reassembly instructions below.

NORMALLY CLOSED CONSTRUCTION (Refer to Figure 2.)

1. Lubricate all gaskets including solenoid base gasket assembly with Dow Corning Corporation's MOLYKOTE® valve seal silicone compound or equivalent.
2. Simultaneously install core/spring assembly (with upper and lower springs) through solenoid base sub-assembly opening and lever/disc assembly through outlet opening in valve body. As they are being installed, position lever in hole in bottom of core. Be sure to position lever/disc assembly so that the lever pin is at the top.
3. Check the engagement of the core/spring assembly with the lever/disc assembly by lifting the core directly upward. Core should remain engaged and movement in the lever/disc assembly noted.
4. Replace solenoid base gasket assembly. Flat surface of solenoid base gasket assembly to seat in valve body. Rounded surface (gasket area) to face solenoid base sub-assembly.
5. Replace solenoid base sub-assembly. Torque solenoid base sub-assembly to 175 ± 25 inch-pounds [19,8 ± 2,8 newton meters].
6. Install spacer, seat gasket and seat into connector. **IMPORTANT: Omit "SPACER" when seat with notched groove cut into hex is supplied in Spare Parts Kit or standard with valve.** For metal seated valves (Suffix "L" in Catalog Number) torque seat to 110 ± 10 inch-pounds [12,4 ± 1,1 newton meters]. For resilient seated valves (Suffix "V" in Catalog Number) torque seat to 90 ± 10 inch-pounds [10,2 ± 1,1 newton meters].
7. Replace connector gasket on connector.
8. Install connector and union nut to valve body and to piping, if removed. Torque union nut to 50 ± 5 foot-pounds [68 ± 6,8 newton meters].
9. Replace solenoid enclosure and retaining cap or clip.
10. After maintenance, operate the valve a few times to be sure of proper operation.

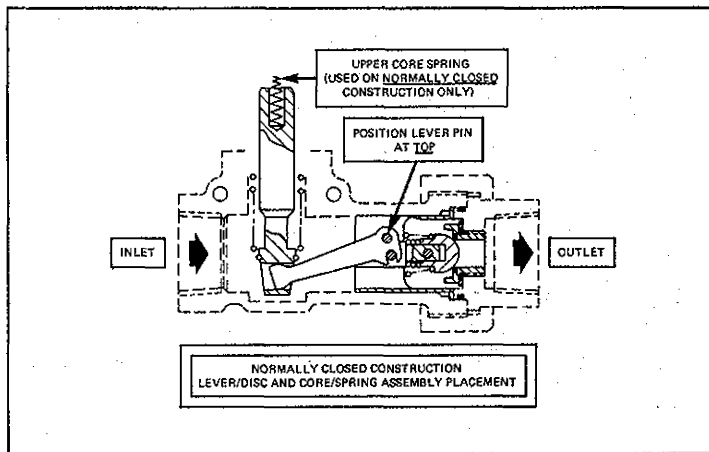

NORMALLY OPEN CONSTRUCTION (Refer to Figure 3.)

1. Lubricate all gaskets including solenoid base gasket assembly with Dow Corning Corporation's MOLYKOTE® valve seal silicone compound or equivalent.
2. Simultaneously install core/spring assembly (lower spring) through solenoid base sub-assembly opening and lever/disc assembly through outlet opening in valve body. As they are being installed, position lever in hole in bottom of core. Be sure to position lever/disc assembly so that the lever pin is at the bottom.
3. Check the engagement of the core/spring assembly with the lever/disc assembly by lifting the core directly upward. Core should remain engaged and movement in the lever/disc assembly noted.
4. Replace solenoid base gasket assembly. Flat surface of the solenoid base gasket assembly to seat in valve body. Rounded surface (gasket area) to face solenoid base sub-assembly.
5. Replace solenoid base sub-assembly. Torque solenoid base sub-assembly to 175 ± 25 inch-pounds [19,8 ± 2,8 newton meters].
6. Install spacer, seat gasket and seat into connector. **IMPORTANT: Omit "SPACER" when seat with notched groove cut into hex is supplied in Spare Parts Kit or standard with valve.** For metal seated valves (Suffix "L" in Catalog Number), torque seat to 110 ± 10 inch-pounds [12,4 ± 1,1 newton meters]. For resilient seated valves (Suffix "V" in Catalog Number) torque seat to 90 ± 10 inch-pounds [10,2 ± 1,1 newton meters].
7. Replace connector gasket on connector.
8. Install connector and union nut to valve body and to piping, if removed. Torque union nut to 50 ± 5 foot-pounds [68 ± 6,8 newton meters].
9. Replace solenoid enclosure and retaining cap or clip.
10. After maintenance, operate the valve a few times to be sure of proper operation.

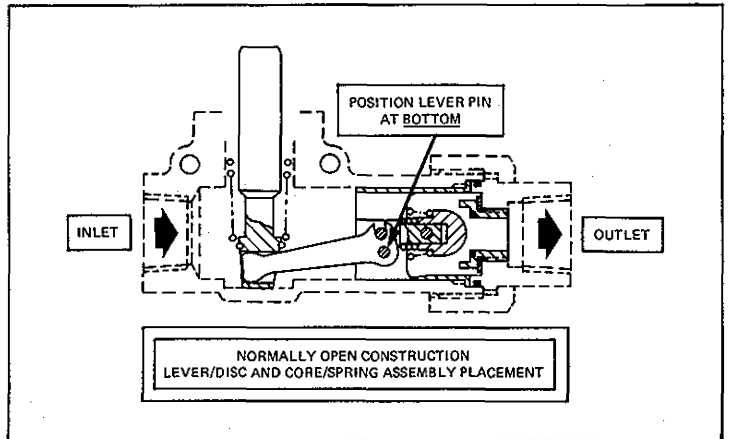

SPARE PARTS KITS

Spare Parts Kits and Coils are available for ASCO valves. Parts marked with an asterisk (*) are supplied in Spare Parts Kits.

ORDERING INFORMATION FOR SPARE PARTS KITS

When Ordering Spare Parts Kits or Coils, Specify Valve Catalog Number, Serial Number and Voltage.

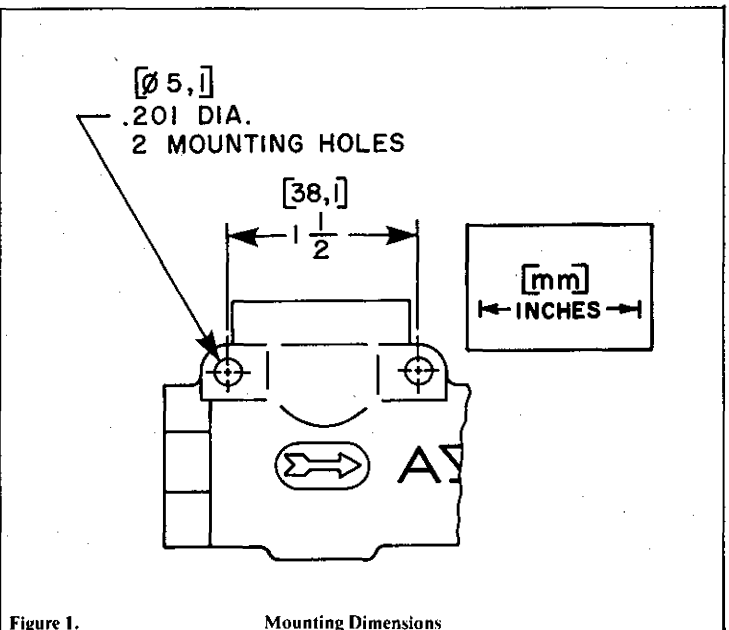
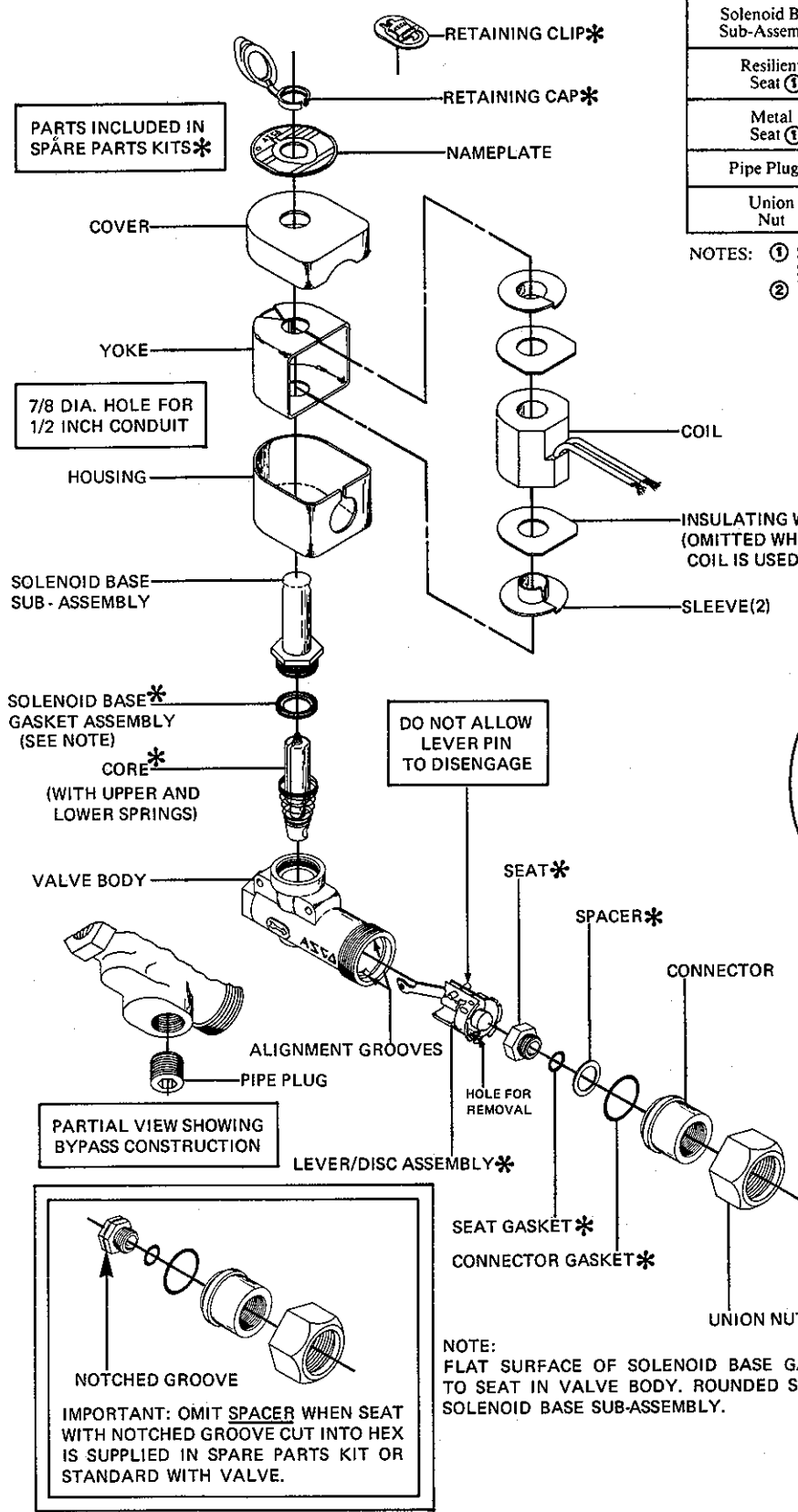

Figure 1. Mounting Dimensions



TORQUE CHART		
Part Name	Torque Value Inch-Pounds	Torque Value Newton Meters
Solenoid Base Sub-Assembly	175 ± 25	19,8 ± 2,8
Resilient Seat ①	90 ± 10	10,2 ± 1,1
Metal Seat ①	110 ± 10	12,4 ± 1,1
Pipe Plug ②	300 ± 30	34 ± 3,4
Union Nut	50 ± 5 (Foot-Pounds)	68 ± 6,8

NOTES: ① Suffix "V" in catalog number indicates resilient seat. Suffix "L" in catalog number indicates metal seat.
 ② Pipe plug present in by-pass construction only.

PARTS INCLUDED IN SPARE PARTS KITS*

7/8 DIA. HOLE FOR 1/2 INCH CONDUIT

DO NOT ALLOW LEVER PIN TO DISENGAGE

PARTIAL VIEW SHOWING BYPASS CONSTRUCTION

NOTCHED GROOVE
 IMPORTANT: OMIT SPACER WHEN SEAT WITH NOTCHED GROOVE CUT INTO HEX IS SUPPLIED IN SPARE PARTS KIT OR STANDARD WITH VALVE.

NOTE: FLAT SURFACE OF SOLENOID BASE GASKET ASSEMBLY TO SEAT IN VALVE BODY. ROUNDED SURFACE TO FACE SOLENOID BASE SUB-ASSEMBLY.

Figure 2.

Bulletin 8266 - Normally Closed Construction
 General Purpose Solenoid Enclosure Shown.
 For Explosion Proof/Watertight Solenoid Enclosure, See Form No. V-5381.

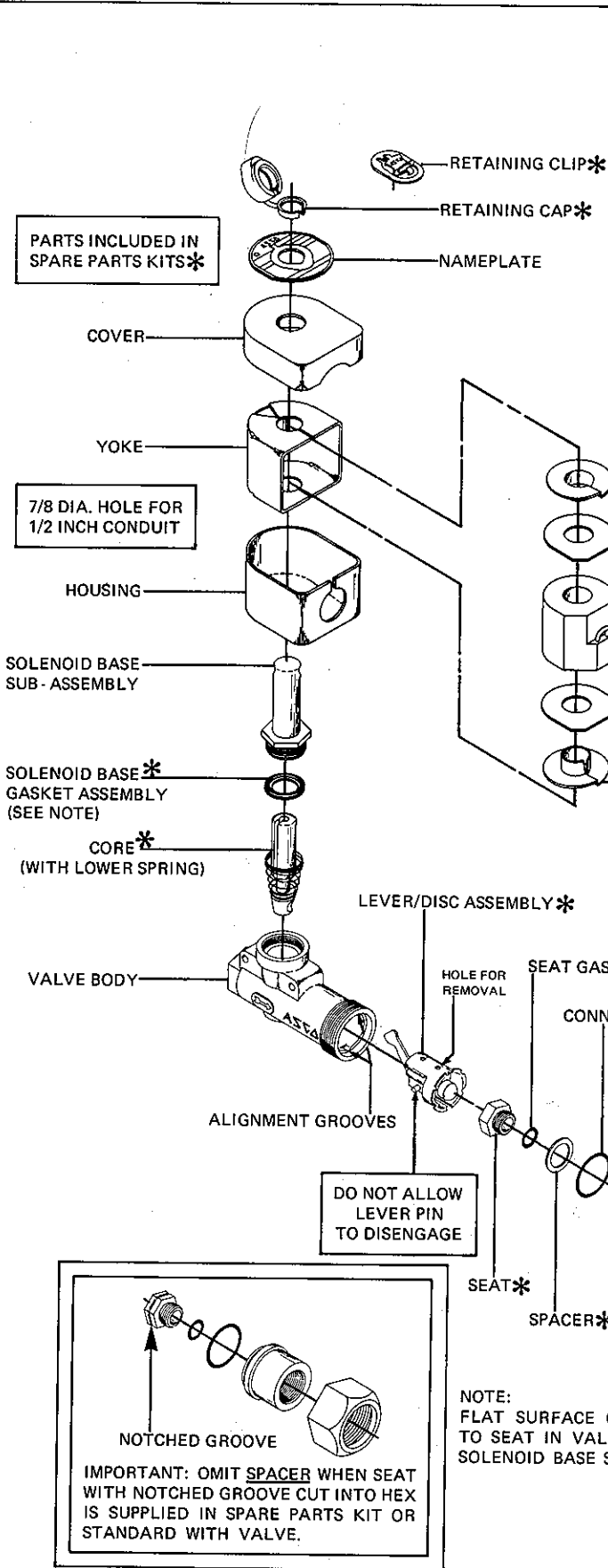

TORQUE CHART		
Part Name	Torque Value Inch-Pounds	Torque Value Newton Meters
Solenoid Base Sub-Assembly	175 ± 25	19,8 ± 2,8
Resilient Seat ①	90 ± 10	10,2 ± 1,1
Metal Seat ①	110 ± 10	12,4 ± 1,1
Union Nut	50 ± 5 (Foot-Pounds)	68 ± 6,8

NOTE ① Suffix "V" in catalog number indicates resilient seat. Suffix "L" in catalog number indicates metal seat.

Figure 3.

Bulletin 8266 - Normally Open Construction
 General Purpose Solenoid Enclosure Shown.
 For Explosion Proof/Watertight Solenoid Enclosure, See Form No. V-5381.