

Features

- Mounts directly to actuators with NAMUR interfaces.
- Designed solely for installation in intrinsically safe areas, with properly approved and sized current and voltage-limiting safety barriers.
- Acceptable for use in hazardous locations, as classified by the National Electrical Code: Classes I, II, and III, Division 1, including Groups A through G.
- Electronically enhanced solenoids have efficient cartridge operators and nonpolarized coils with triple redundant blocking diodes.
- Capacitor stores power required to open the valve, while blocking diodes prevent it from flowing back into the wiring in the hazardous area.
- Low Power and General Purpose constructions are available.

Construction

Valve Parts in Contact with Fluids		
Body	Anodized Aluminum	316 Stainless Steel
Seals and Disc	NBR and PUR	
Sleeve	304L Stainless Steel	
Core Spring	302 Stainless Steel	
Core and Plugnut	430F Stainless Steel	
Rider Ring	PTFE	
Spring Retainer	CA	
End Covers	Glass Filled PA + FV	316 Stainless Steel
Spool	Stainless Steel	
Internals	Zamak, Steel, CA	

Solenoid Enclosures

Standard: Watertight, Type 4.
Optional: For 316 stainless steel, metal Watertight Box, Type 4X (on aluminum bodied valves), specify prefix "WS". For DIN IP65, specify prefix "ISSC". For open frame, screw terminal, specify prefix "U". For Liquid Crystal Polymer, Watertight, Type 1, 2, 3, 4, 4X, specify prefix "WB".
See Optional Features Section for other available options.

Electrical

Normal Operating Voltage — 24 volts DC, ±10%.
 Maximum Allowable "Off" State Current to the Valves must be less than 1 mA.

Electronically Enhanced "IS" Solenoid:

Maximum Capacitor Charge Time — 1 second
 Minimum Time between Cycles — 1 second
 Minimum Drop Current to Reset Electronic Coil — 2 mA
 Nominal Temperature Rise at 24 VDC and 300 Ohms — 2°C (36°F)
 Maximum Recommended Wire Run (#18 Wire) — 1.5 miles from barrier to valve

IMPORTANT: Minimum series resistance of 200 ohms required in wiring circuit if a safety barrier is not used for non-"IS" system.

$$\text{Maximum Operating Current (amps)} = \frac{V - 2.4}{R_B + R_L + 150}$$

$$\text{Maximum Charging Current (amps)} = \frac{V - 1.8}{R_B + R_L + 52}$$

V = Supply Voltage
 R_B = Barrier or Current Limiting Resistance
 R_L = Line Resistance (wiring)

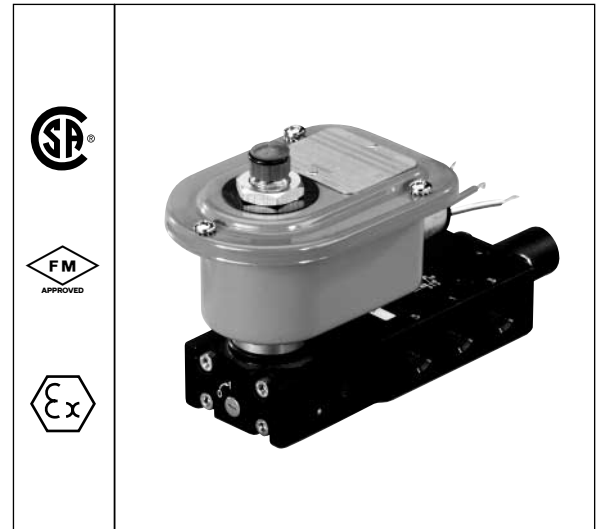

Nominal Ambient Temperature Ranges:

-4°F to 140°F (-20°C to 60°C)
Refer to Engineering Section for details.

Approvals:

FM approved under J.I.3W8A8.AX (3610). CSA certified under File LR-13976-116C.
 CENELEC EEx ia IIC T6 approved.
Refer to Engineering Section for details.

Important:

These solenoids are intended for use on clean, dry air or inert gas filtered to 50 micrometers or better. To prevent freezing, the dew point of the media should be at least 18°F (-8°C) below the minimum temperature to which any portion of the clean air or gas system could be exposed. Instrument air in compliance with ANSI/ISA Standard S7.3-1975 (R1981) exceeds the above requirements and is, therefore, an acceptable medium for these valves.

Operating Parameters	Voltage @ 86°F (30°C)		
	21.6	24.0	26.4
Maximum Series Resistance in Ohms	510	610	690
Maximum Holding Current with 300 Ohm Barrier	43	48	54
Nominal Coil Watts with 300 Ohm Barrier	0.38	0.46	0.57

Entity	Groups A-D	Groups C-D
Parameters	V max - 30 VDC	V max - 34 VDC
	I max - 100 mA	I max - 125 mA
	Capacitance = 0	Capacitance = 0
	Inductance = 0	Inductance = 0

Coil: Continuous duty molded Class A.
Minimum Operating Current: 0.028 amps.

Specifications (English units)

Pipe Size (ins.)	Orifice Size (ins.)	Cv Flow Factor	Single Solenoid							Dual Solenoid				
			Operating Pressure Differential (psi) Air-Inert Gas		Max. Fluid Temp. °F	Aluminum Body	316 Stainless Steel Body	Constr. Ref. No.	Operating Pressure Differential (psi) Air-Inert Gas		Max. Fluid Temp. °F	Aluminum Body	316 Stainless Steel Body	Constr. Ref. No.
			Min.	Max.	24/DC Only	Catalog Number			Min.	Max.	24/DC Only	Catalog Number		
3/2 VALVES - NORMALLY CLOSED with breather block														
1/4	1/4	.60	35	150	140	WPIS8551A378	-	9	20	150	140	WPIS8551A380	-	10
4/2 VALVES														
1/4	1/4	.84	35	150	140	WPIS8551A387	WSIS8551A388	11	20	150	140	WPIS8551A389	WSIS8551A390	12

Specifications (Metric units)

Pipe Size (ins.)	Orifice Size (mm)	Kv Flow Factor (m3/h)	Single Solenoid							Dual Solenoid				
			Operating Pressure Differential (bar) Air-Inert Gas		Max. Fluid Temp. °C	Aluminum Body	316 Stainless Steel Body	Constr. Ref. No.	Operating Pressure Differential (bar) Air-Inert Gas		Max. Fluid Temp. °C	Aluminum Body	316 Stainless Steel Body	Constr. Ref. No.
			Min.	Max.	24/DC Only	Catalog Number			Min.	Max.	24/DC Only	Catalog Number		
3/2 VALVES - NORMALLY CLOSED with breather block														
1/4	6	.51	2.4	10.3425	59	WPIS8551A378	--	9	1.379	10.3	59	WPIS8551A380	--	10
4/2 VALVES														
1/4	6	.72	2.4	10.3	59	WPIS8551A387	WSIS8551A388	11	1.4	10.3	59	WPIS8551A389	WSIS8551A390	12

Dimensions: inches (mm)

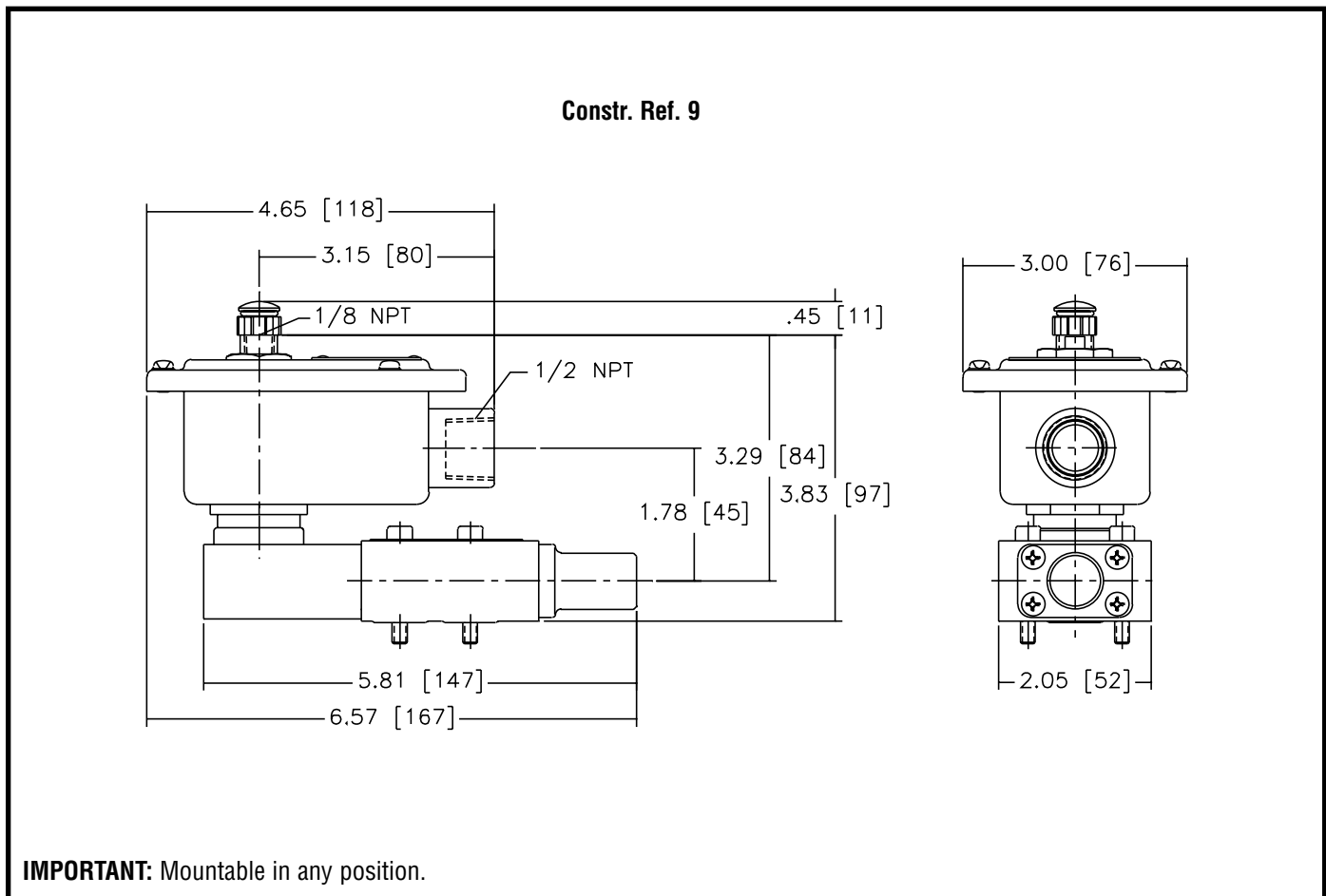

Dimensions: inches (mm)

Constr. Ref. 10

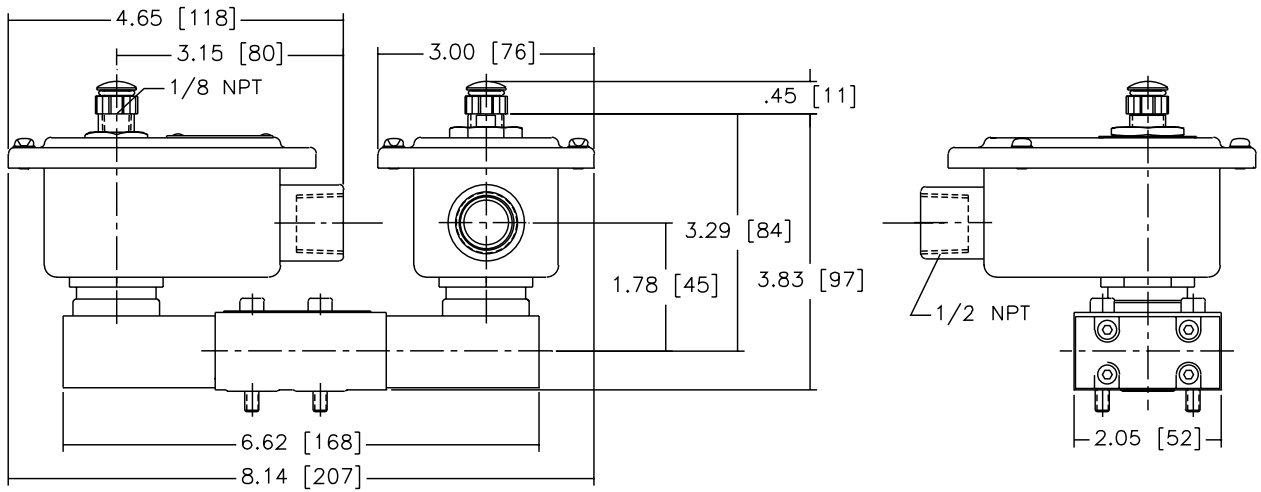

Constr. Ref. 11

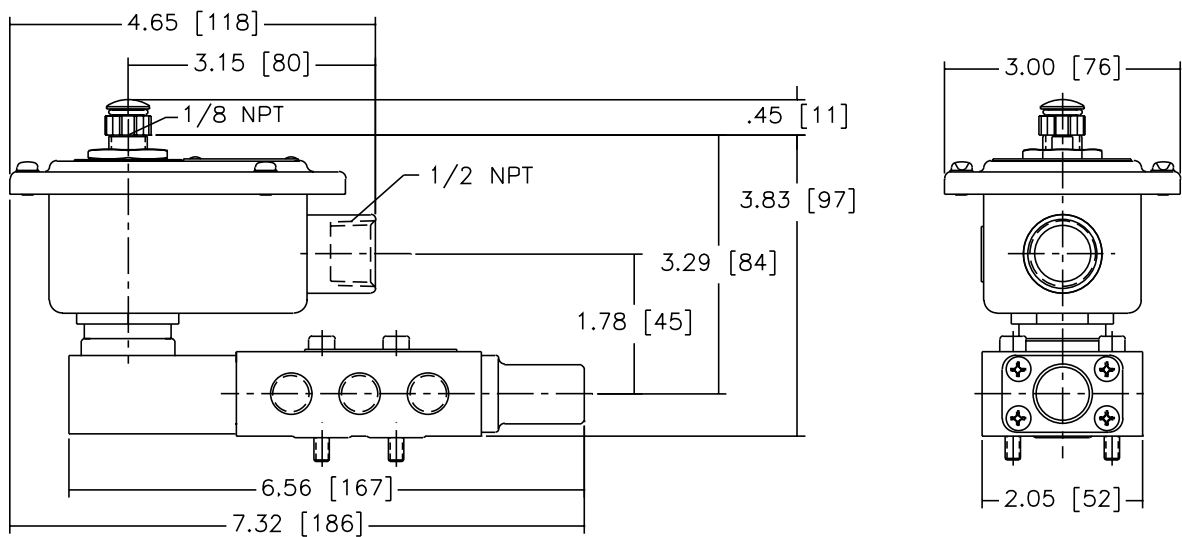

Dimensions: inches (mm)

Constr. Ref. 12

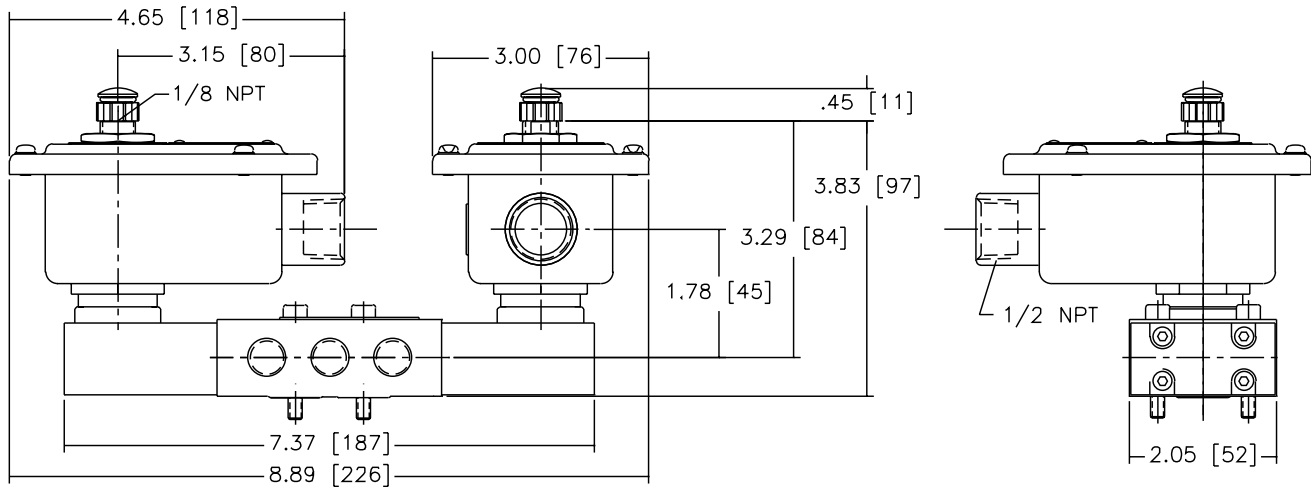

Mounting Hole in Valve Body

