

## XYR6000 Wireless Transmitter Gauge Pressure Models

STGW944	0 to 500 psi	0 to 35 bar
STGW94L	0 to 500 psi	0 to 35 bar
STGW974	0 to 3000 psi	0 to 210 bar
STGW97L	0 to 3000 psi	0 to 210 bar
STGW98L	0 to 6000 psi	0 to 415 bar

## Specification and Model Selection Guide

### Introduction

Building upon the tremendously successful ST 3000 series transmitter line; Honeywell brings simple, safe, and secure wireless technology to its measurement portfolio in the XYR 6000 Series Wireless Transmitters.

The XYR 6000 series measurements are part of the WNSIA (Wireless Network for Secure Industrial Applications) compliant field devices.

Measurement and information without wires! The XYR 6000 wireless transmitter series enable customers to obtain data and create information from remote and hazardous measurement locations without the need to run wires, where running wire is cost prohibitive and/or the measurement is in a hazardous location. Without wires, transmitters can be installed and operational in minutes, quickly providing information back to your system.

XYR 6000 wireless transmitters send information to a multinode or series of multinodes creating a MESH infrastructure. Wireless System Gateways (WSG) provide the path to bring that information into Experion PKS or any other control system wirelessly via OPC client or Modbus-TCP.

Each multinode accepts signals from up to 20 wireless transmitters reporting at 1 second, and up to 400 transmitters reporting at slower rates. Up to 20 multinodes can be implemented in the same infrastructure.

Transmitter power is supplied by two "D" size lithium batteries with an expected lifetime of up to ten years. Transmitter range with the integral antenna is 1000' (305 m) under ideal conditions.

Pressure transmitters continue to bring a proven technology to a wide spectrum of pressure measurement applications, from furnace combustion airflow rate to hydrostatic tank gauging.

The STGW series Gauge Pressure can be used with any primary flow element to provide proven, repeatable flow measurement.



Figure 1—XYR6000 Gauge Pressure Transmitters

Implement the value of wireless technology today:

- Measure remote access points simply, safe and securely
- Obtain and utilize previously inaccessible information due to high wiring cost or hazardous locations.
- Easily meet Regulatory Requirements
- Improve process efficiency
- Enhance Flexibility to monitor applications:
  - that have no access to power
  - that are remote or difficult to reach
  - that may require frequent reconfiguration
  - where manual readings have been required previously.

## Specifications

### Operating Conditions – All Models

Parameter	Reference Condition (at zero static)		Rated Condition		Operative Limits		Transportation and Storage	
	°C	°F	°C	°F	°C	°F	°C	°F
<b>Ambient Temperature</b>	25 ±1	77 ±2	-40 to 70	-40 to 158	-40 to 85	-40 to 185	-40 to 85	-40 to 185
<b>Meter Body Temperature</b>	25 ±1	77 ±2	-40 to 110*	-40 to 230*	-40 to 125**	-40 to 257**	-40 to 85	-40 to 185
<b>Humidity</b> %RH	10 to 55		0 to 100		0 to 100		0 to 100	
<b>Vacuum Region - Minimum Pressure</b>								
<b>mmHg absolute</b>	atmospheric		25		2 (short term ***)			
<b>inH<sub>2</sub>O absolute</b>	atmospheric		13		1 (short term ***)			
<b>Maximum Allowable Working Pressure (MAWP)</b> (XYR6000 products are rated to Maximum Allowable Working Pressure. MAWP depends on Approval Agency and transmitter materials of construction.)	STGW944 and STGW94L = 500 psi, 35 bar STGW974 and STGW97L = 3000 psi, 210 bar STGW98L = 6000 psi, 415 bar Units can withstand overpressure of 1.5X MAWP without damage.							
<b>Vibration</b>	Maximum of 4g over 15 to 200Hz.							
<b>Shock</b>	Maximum of 40g.							

\* For model 944 with CTFE fill fluid, the rating is -15 to 70°C (5 to 158°F); for model 98L with CTFE fill fluid, the rating is -15 to 110°C (5 to 230°F).

\*\* For Models STGW94L, STGW97L, and STGW98L the upper limit is 110°C (230°F).

\*\*\* Short term equals 2 hours at 70°C (158 °F)

### Wireless Specifications

Parameter	Description
<b>Wireless Communication</b>	2,400 to 2,483.5 MHz (2.4 GHz) Frequency Hopping Spread Spectrum (FHSS) USA – FCC Certified Canada – IC Certified European Union – RTTE/ETSI Conformity
<b>RF Transmitter Power</b>	125 mW (20.9 dBm) maximum per FCC/IC not including antenna, or 400 mW (26.0 dBm) maximum EIRP including antenna for USA and Canadian locations. 100 mW (20.0 dBm) maximum EIRP per RTTE/ETSI including antenna for EU locations.
<b>Data</b>	Rate: 250 Kbps
<b>Antennas</b>	Integral – 2 dBi omnidirectional monopole Remote – 8 dBi omnidirectional monopole with up to 20 m cable and lightning surge arrester. Remote – 14 dBi Directional parabolic with up to 20 m cable and lightning surge arrester.
<b>Signal Range</b>	Nominal 305 m (1,000 feet) between Field Transmitter and Infrastructure Unit (multinode) or Gateway Unit with a clear line of sight.*

\* Actual range will vary depending on antennas, cables and site topography.

### Remote antenna

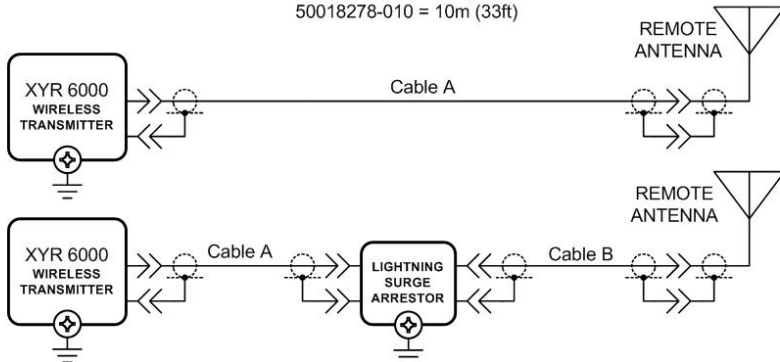
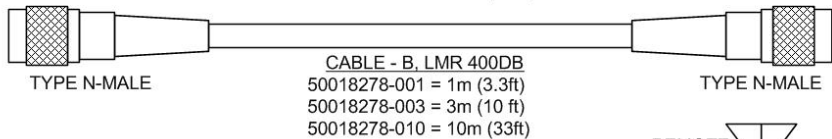
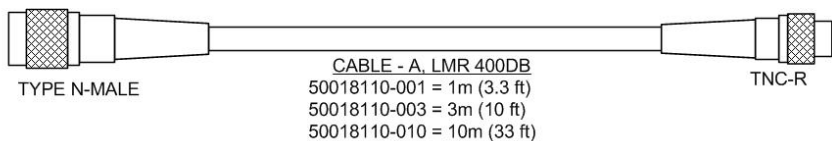

CABLE PARAMETERS			LIGHTNING SURGE ARRESTOR PARAMETERS
CABLE A, B LENGTH	CAPACITANCE	INDUCTANCE	
1 m	78.4 pF	0.2 μH	CAPACITANCE = 1 pF INDUCTANCE = 10 nH
3 m	235.2 pF	0.6 μH	
10 m	784 pF	2.0 μH	

**Performance Under Rated Conditions\* - Models STGW944 & 94L (0 to 500 psi/35 bar)**

Parameter		Description
<b>Upper Range Limit</b>	<b>psi</b> <b>bar</b>	500 35
<b>Minimum Span</b>	<b>psi</b> <b>bar</b>	20 1.4
<b>Zero Elevation and Suppression</b>		No limit except minimum span from absolute 0 (zero) to +100% URL. Specifications valid over this range.
<b>Accuracy</b> (Reference – Includes combined effects of linearity, hysteresis, and repeatability)  • <i>Accuracy includes residual error after averaging successive readings.</i>		±0.10% of calibrated span or upper range value (URV), whichever is greater, terminal based. For URV below reference point (20 psi), accuracy equals:  $\pm 0.10 \left( \frac{20 \text{ psi}}{\text{span psi}} \right)$ or $\pm 0.10 \left( \frac{1.4 \text{ bar}}{\text{span bar}} \right)$ in % of span
<b>Zero Temperature Effect per 28°C (50°F)</b>		±0.15% of span. For URV below reference point (50 psi), effect equals:  $\pm 0.15 \left( \frac{50 \text{ psi}}{\text{span psi}} \right)$ or $\pm 0.15 \left( \frac{3.5 \text{ bar}}{\text{span bar}} \right)$ in % of span
<b>Combined Zero and Span Temperature Effect per 28°C (50°F)</b>		±0.225% of span. For URV below reference point (50 psi), effect equals:  $\pm \left[ 0.075 + 0.15 \left( \frac{50 \text{ psi}}{\text{span psi}} \right) \right]$ or $\pm \left[ 0.075 + 0.15 \left( \frac{3.5 \text{ bar}}{\text{span bar}} \right) \right]$ in % of span
<b>Stability</b>		±0.015% of URL per year

\* Performance specifications are based on reference conditions of 25°C (77°F), 10 to 55% RH, and 316L Stainless Steel barrier diaphragm.

**Performance Under Rated Conditions\* - Models STGW974 & 97L (0 to 3000 psi/210 bar)**

Parameter	Description
<b>Upper Range Limit</b> <b>psi</b> <b>bar</b>	3000 210
<b>Minimum Span</b> <b>psi</b> <b>bar</b>	300 21
<b>Zero Elevation and Suppression</b>	No limit except minimum span from absolute 0 (zero) to +100% URL. Specifications valid over this range.
<b>Accuracy</b> (Reference – Includes combined effects of linearity, hysteresis, and repeatability)  • <i>Accuracy includes residual error after averaging successive readings.</i>	±0.10% of calibrated span or upper range value (URV), whichever is greater, terminal based. For URV below reference point (750 psi), accuracy equals:  $\pm 0.10 \left( \frac{750 \text{ psi}}{\text{span psi}} \right) \text{ or } \pm 0.10 \left( \frac{52 \text{ bar}}{\text{span bar}} \right) \text{ in \% of span}$
<b>Zero Temperature Effect per 28°C (50°F)</b>	±0.20% of span. For URV below reference point (500 psi), effect equals:  $\pm 0.20 \left( \frac{500 \text{ psi}}{\text{span psi}} \right) \text{ or } \pm 0.20 \left( \frac{35 \text{ bar}}{\text{span bar}} \right) \text{ in \% of span}$
<b>Combined Zero and Span Temperature Effect per 28°C (50°F)</b>	±0.30% of span. For URV below reference point (500 psi), effect equals:  $\pm \left[ 0.10 + 0.20 \left( \frac{500 \text{ psi}}{\text{span psi}} \right) \right] \text{ or } \pm \left[ 0.10 + 0.20 \left( \frac{35 \text{ bar}}{\text{span bar}} \right) \right] \text{ in \% of span}$
<b>Stability</b>	±0.03% of URL per year

\* Performance specifications are based on reference conditions of 25°C (77°F), 10 to 55% RH, and 316L Stainless Steel barrier diaphragm.

**Performance Under Rated Conditions\* - Model STGW98L (0 to 6000 psi/415 bar)**

Parameter	Description
<b>Upper Range Limit</b> <b>psi</b> <b>bar</b>	6000 415
<b>Minimum Span</b> <b>psi</b> <b>bar</b>	500 35
<b>Zero Elevation and Suppression</b>	No limit except minimum span from absolute 0 (zero) to +100% URL. Specifications valid over this range.
<b>Accuracy</b> (Reference – Includes combined effects of linearity, hysteresis, and repeatability)  • <i>Accuracy includes residual error after averaging successive readings.</i>	±0.10% of calibrated span or upper range value (URV), whichever is greater, terminal based. For URV below reference point (1500 psi), accuracy equals:  $\pm 0.10 \left( \frac{1500 \text{ psi}}{\text{span psi}} \right) \text{ or } \pm 0.10 \left( \frac{104 \text{ bar}}{\text{span bar}} \right) \text{ in \% of span}$
<b>Zero Temperature Effect per 28°C (50°F)</b>	±0.20% of span. For URV below reference point (1500 psi), effect equals:  $\pm 0.20 \left( \frac{1500 \text{ psi}}{\text{span psi}} \right) \text{ or } \pm 0.20 \left( \frac{70 \text{ bar}}{\text{span bar}} \right) \text{ in \% of span}$
<b>Combined Zero and Span Temperature Effect per 28°C (50°F)</b>	±0.30% of span. For URV below reference point (1500 psi), effect equals:  $\pm \left[ 0.10 + 0.20 \left( \frac{1500 \text{ psi}}{\text{span psi}} \right) \right] \text{ or } \pm \left[ 0.10 + 0.20 \left( \frac{104 \text{ bar}}{\text{span bar}} \right) \right] \text{ in \% of span}$
<b>Stability</b>	±0.03% of URL per year

\* Performance specifications are based on reference conditions of 25°C (77°F), 10 to 55% RH, and 316L Stainless Steel barrier diaphragm.

### Performance under Rated Conditions – General for all Models

Parameter	Description
<b>Lightning Surge Arrester (Remote antenna only)</b>	Frequency range: 0 – 3 GHz, 50 Ohms, VSWR = 1:1.3 Max, Insertion Loss = 0.4 dB Connectors Type N Female, Max, Gas Tube Element: 90 V ± 20%, Impulse Breakdown Voltage = 1,000 V ± 20%, Maximum Withstand Current = 5 KA.
<b>CE Conformity</b>	These transmitters are in conformity with the protection requirements of European Council Directives: 89/336/EEC, the EMC Directive and 1999/5/EC, the Telecommunications Directive per EN 300 328, V1.6.1 (2004-11), EN 300 489-1, V1.6.1 (2005-09), EN 300 489-3, V1.4.1 (2002-08) and EN 61326-1997+A1+A2, Electrical Equipment for Measurement, Control and Laboratory Use – EMC Requirements.
<b>Hazardous Location Certifications</b>	See the Model Selection Guide.

### Physical and Approval Bodies

Parameter	Description
<b>Barrier Diaphragm Material</b>	<b>Dual-Head Meter Body:</b> 316L SS, Hastelloy C-276, Monel 400, Tantalum <b>In-Line Meter Body:</b> 316L SS, Hastelloy C-276
<b>Process Head Material</b>	<b>Dual-Head Meter Body:</b> Carbon Steel (zinc-plated), 316 SS, Hastelloy C-276, Monel. [Standard reference head is Carbon Steel (zinc-plated). Optional reference head is 316 SS.] <b>In-Line Meter Body:</b> 316L SS process interface.
<b>Head Gaskets</b>	Teflon is standard. Viton is available.
<b>Meter Body Bolting</b>	Carbon Steel (Zinc plated) standard. Options include 316 SS, NACE A286 SS bolts with 304 SS nuts, and B7M.
<b>Mounting Bracket</b>	Carbon Steel (Zinc-plated) or Stainless Steel angle bracket or Carbon Steel flat bracket available.
<b>Fill Fluid</b>	Silicone oil or CTFE (Chlorotrifluoroethylene)
<b>Electronic Housing</b>	Epoxy-Polyester hybrid paint. Low Copper-Aluminum. Meets NEMA 4X (hosedown and corrosion resistant), IP 66/67 (hosedown and submersible to 1m).
<b>Process Connections</b>	<b>Dual-Head Meter Body:</b> 1/4-inch F-NPT and DIN 19213 are standard. 1/2-inch F-NPT with optional adapter flange. <b>In-Line Meter Body:</b> 1/2-inch F-NPT, 1/2 inch M-NPT, 9/16 AMINCO, DIN 19213
<b>Mounting</b>	Can be mounted in virtually any position using the standard mounting bracket. Mounting should result in the antenna being vertically oriented. Bracket is designed to mount on 2-inch (50 mm) vertical or horizontal pipe. See Figure 3 for dual-head models, and Figure 4 for in-line models.
<b>Dimensions</b>	See Figures 5 and 6.
<b>Net Weight</b>	<b>With Dual-Head Meter Body:</b> 11 pounds (5 Kg) <b>With In-Line Meter Body:</b> 7 pounds (3.2 Kg)

**NOTE:** Pressure transmitters that are part of safety equipment for the protection of piping (systems) or vessel(s) from exceeding allowable pressure limits, (equipment with safety functions in accordance with Pressure Equipment Directive 97/23/EC article 1, 2.1.3), require separate examination.

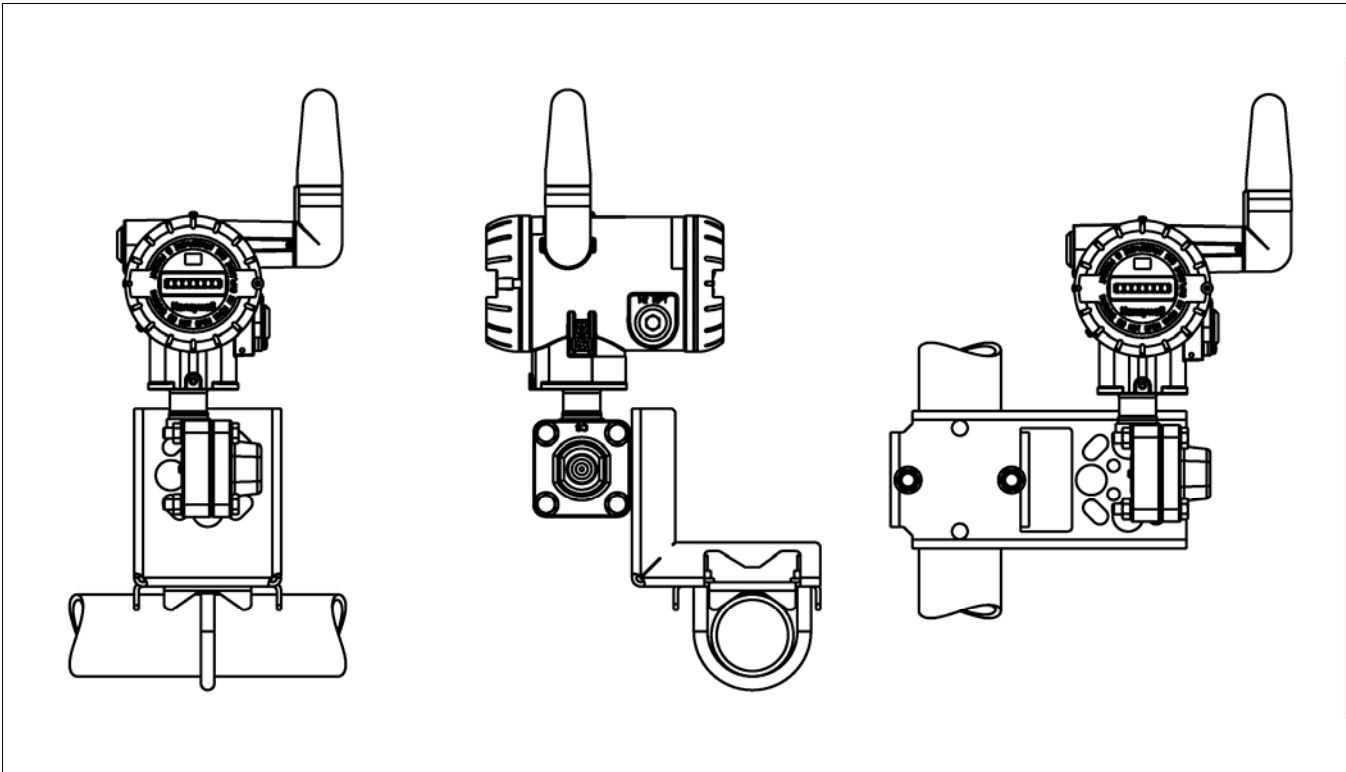

**Figure 3**—Examples of typical mounting positions for dual-head models STGW944 and STGW974

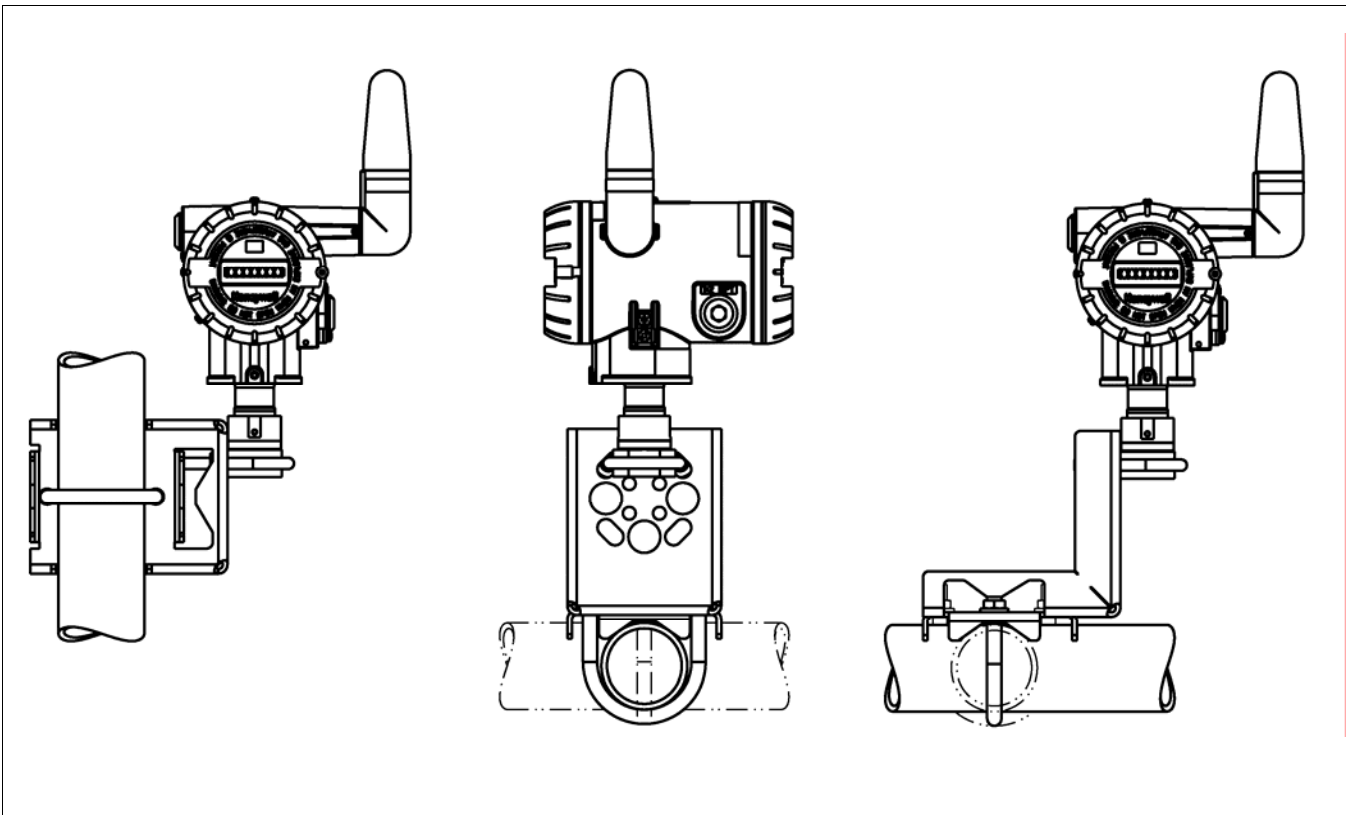

**Figure 4**—Examples of typical mounting positions for in-line models STGW94L, STGW97L, STGW98L. Note that a mounting bracket is not required for in-line models.

Reference Dimensions:  $\frac{\text{millimeters}}{\text{inches}}$

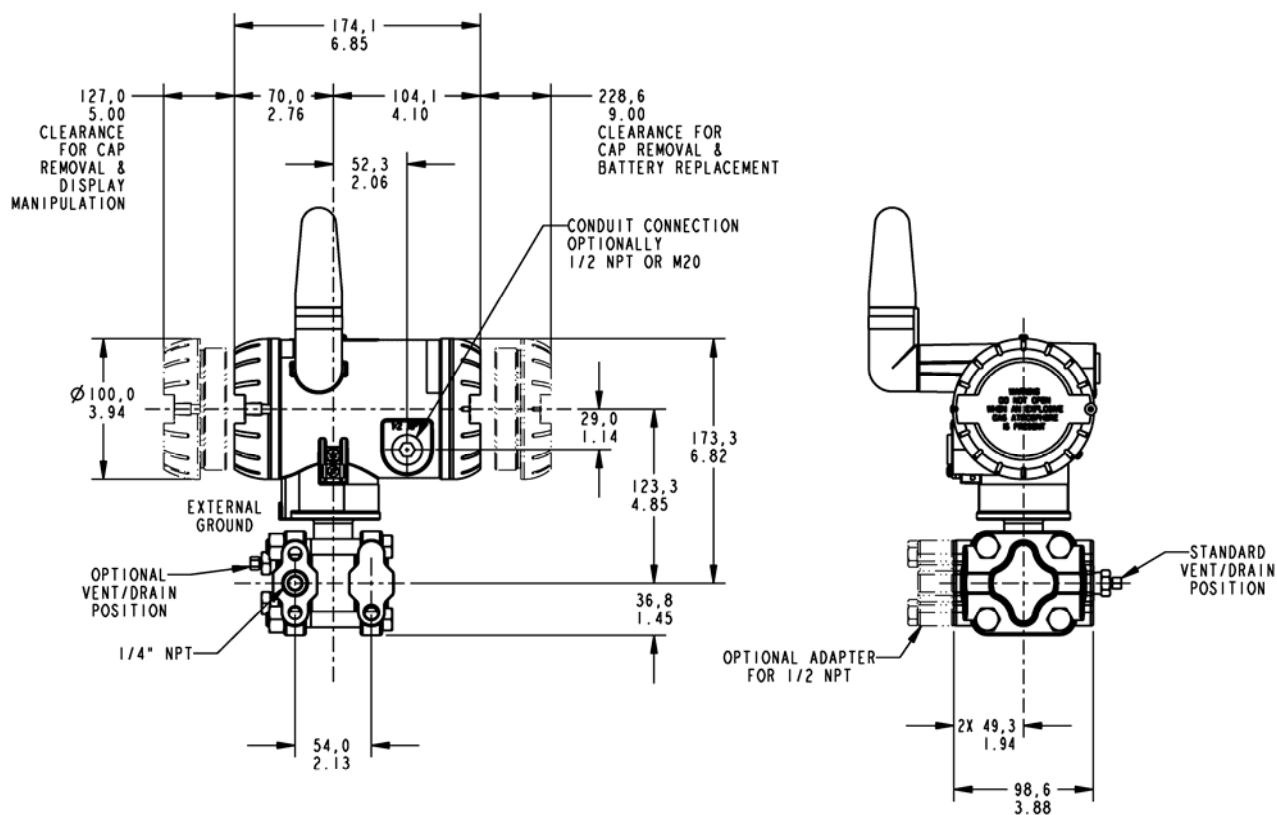

Figure 5—Typical mounting dimensions for dual-head models STGW944 and STGW974 for reference

Reference Dimensions:  $\frac{\text{millimeters}}{\text{inches}}$

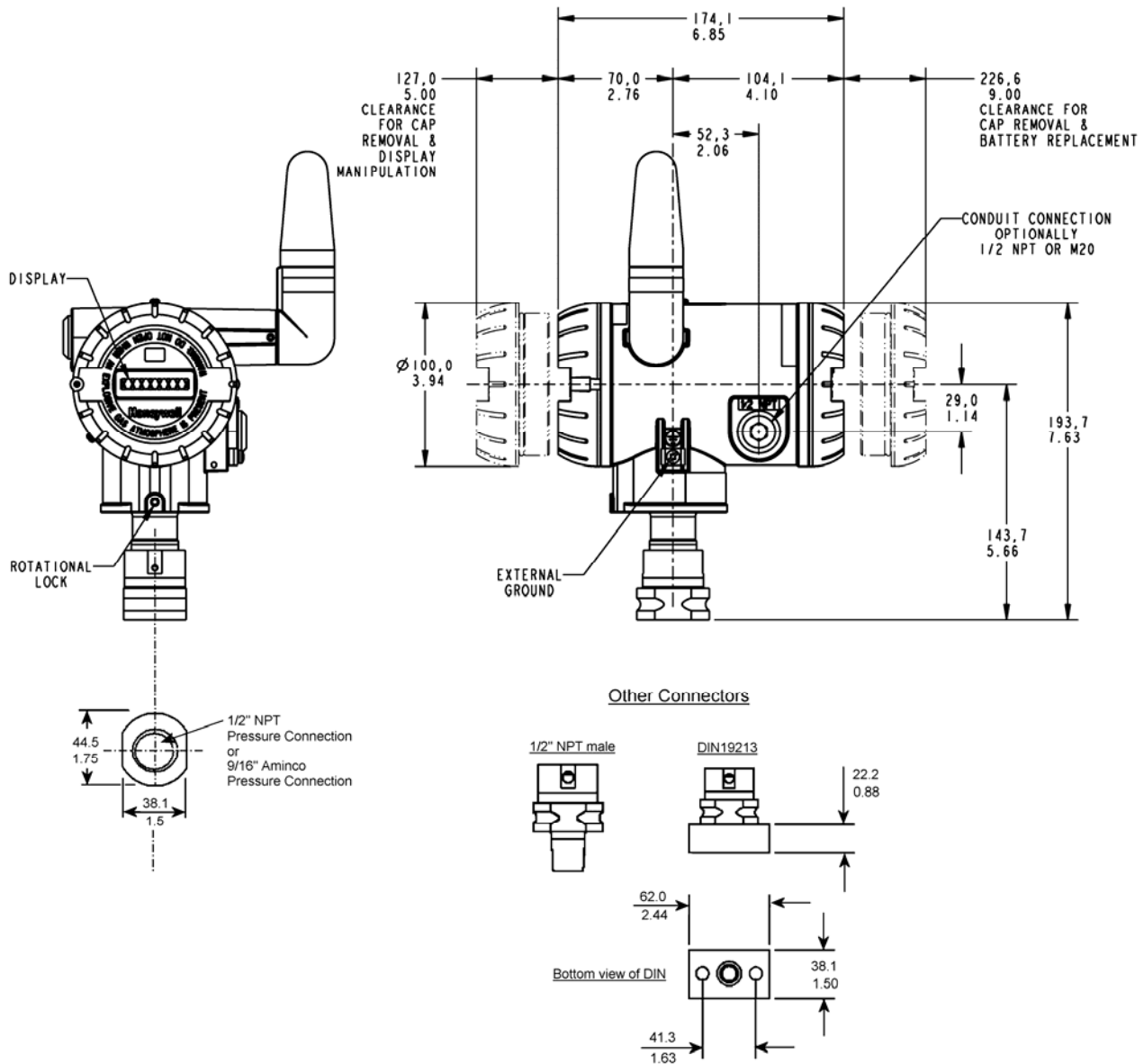

Figure 6—Typical mounting dimensions for in-line models STGW94L, STGW97L, STGW98L, and STGW99L for reference

## Options

### **Mounting Bracket**

The angle mounting bracket is available in either zinc-plated carbon steel or stainless steel and is suitable for horizontal or vertical mounting on a two inch (50 millimeter) pipe, as well as wall mounting. An optional flat mounting bracket is also available in carbon steel for two inch (50 millimeter) pipe mounting.

### **Transmitter Configuration**

All configurable parameters are accessible via the WNSIA network via READ/WRITE transactions.

I

### **Tagging (Option TG)**

Up to 30 characters can be added on the stainless steel nameplate mounted on the transmitter's electronics housing at no extra cost. A stainless steel wired on tag with additional data of up to 4 lines of 28 characters is also available. The number of characters for tagging includes spaces.

## Ordering Information

Contact your nearest Honeywell sales office, or

In the U.S.:

Honeywell  
Industrial Automation & Control  
2500 W. Union Hills Ave  
Phoenix, AZ 85053  
1-800-288-7491

In Canada:

The Honeywell Centre  
155 Gordon Baker Rd.  
North York, Ontario M2H 3N7  
1-800-461-0013

In Latin America:

Honeywell Inc.  
480 Sawgrass Corporate Parkway,  
Suite 200  
Sunrise, FL 33325  
(954) 845-2600

In Europe and Africa:

Honeywell S. A.  
Avenue du Bourget 1  
1140 Brussels, Belgium

In Eastern Europe:

Honeywell Praha,  
s.r.o. Budejovicka 1  
140 21 Prague 4,  
Czech Republic

In the Middle East:

Honeywell Middle East Ltd.  
Khalifa Street,  
Sheikh Faisal Building  
Abu Dhabi, U. A. E.

In Asia:

Honeywell Asia Pacific Inc.  
Honeywell Building,  
17 Changi Business Park Central 1  
Singapore 486073  
Republic of Singapore

In the Pacific:

Honeywell Pty Ltd.  
5 Thomas Holt Drive  
North Ryde NSW Australia 2113  
(61 2) 9353 7000

In Japan:

Honeywell K.K.  
14-6 Shibaura 1-chrome  
Minato-ku, Tokyo, Japan 105-0023

Or, visit Honeywell on the World Wide Web at: <http://www.honeywell.com>

*Specifications are subject to change without notice.*

**Model Selection Guide (34-XY-16-34)**

**Instructions**

- Select the desired Key Number. The arrow to the right marks the selection available.
- Make one selection from each table, I and II, using the column below the proper arrow.
- Select as many Table III options as desired (if no options or approvals are desired, specify 9X).
- A (★) denotes unrestricted availability. A letter denotes restricted availability.  
Restrictions follow Table V.

**Key Number**      **I**      **II**      **III**      **IV**      **V**  
STGW\_\_ - \_\_ - 00000 - \_\_\_\_\_ - \_.,\_.,\_. - XXXX

KEY NUMBER	Span	Selection	Availability
Gage Pressure	0-20 to 0-500 psi/0-1.4 to 0-35 bar	STGW944	↓
	0-300 to 0-3000 psi/0-21 to 0-210 bar	STGW974	↓

**TABLE I - METER BODY**

	Wetted Process Head ***	Vent/Drain Valve **	Barrier Diaphragms		
Materials of Construction	Carbon Steel *	316 SS	316L SS	A__	•
	Carbon Steel *	316 SS	Hastelloy C	B__	•
	Carbon Steel *	316 SS	Monel	C__	•
	Carbon Steel *	316 SS	Tantalum	D__	•
	316 SS	316 SS	316L SS	E__	•
	316 SS	316 SS	Hastelloy C	F__	•
	316 SS	316 SS	Monel	G__	•
	316 SS	316 SS	Tantalum	H__	•
	Hastelloy C	Hastelloy C	Hastelloy C	J__	•
	Hastelloy C	Hastelloy C	Tantalum	K__	•
Monel	Monel	Monel	L__	•	
Fill Fluid	Silicone DC200 ****			_1_	•
	CTFE			_2_	•
Process Head Configuration	1/4" NPT			__A	•
	1/2" NPT with Adapter			__G	k

**TABLE II**

No Selection	00000	•
--------------	-------	---

\* Carbon Steel heads are zinc-plated. Not recommended for water service due to hydrogen migration. Use Stainless Steel heads.

\*\* Vent/Drains are Teflon coated for lubricity.

\*\*\* The standard reference head for the STGW9XX is carbon steel (zinc-plated). See Table III for a stainless steel reference (HR) head option.

**Note:** End vent drain valve standard for STGW9XX.

**TABLE III - ANTENNA OPTIONS**

		Selection	Availability
Antenna's	Integral Right-angle, vertical (Standard)	V _ _ _ _	d
	Integral Straight, horizontal	S _ _ _ _	d
	Remote Omnidirectional, 8 dBi	M _ _ _ _	e
	Remote Directional, 14 dBi	D _ _ _ _	e
Cable A for Remote Antenna	None	_ 0 0 _ _	•
	1.0m remote Cable A, TNC-R - N (Req'd to connect to XYR 6000)	_ 0 1 _ _	•
	3.0m remote Cable A, TNC-R - N (Req'd to connect to XYR 6000)	_ 0 3 _ _	•
	10.0m remote Cable A, TNC-R - N (Req'd to connect to XYR 6000)	_ 1 0 _ _	•
Lightning Protection for remote Antenna With Cable B	None	_ _ _ 0 0	•
	Lightning Protection + 1.0m Cable B to Antenna, N - N	_ _ _ 0 1	•
	Lightning Protection + 3.0m Cable B to Antenna, N - N	_ _ _ 0 3	•
	Lightning Protection + 10.0m Cable B to Antenna, N - N	_ _ _ 1 0	•

**TABLE IV - OPTIONS**

None	00	•	
<b>Transmitter Housing &amp; Electronics Options</b>			
Custom Calibration and I.D. in Memory	CC		
Transmitter Configuration and ID in Memory	TC	•	
M20 Conduit Thread (1/2" NPT is standard)	A1	•	b
1/2" NPT to 3/4" NPT 316 SS Conduit Adapter	A2	•	
Stainless Steel Customer Wired-On Tag (4 lines, 28 characters per line, customer supplied information)	TG	•	b
Stainless Steel Customer Wired-On Tag (blank)	TB	•	
End Cap Warning Label in Spanish	SP	•	
End Cap Warning Label in Portuguese	PG	•	b
End Cap Warning Label in Italian	TL	•	
End Cap Warning Label in German	GE	•	
<b>Meter Body Options</b>			
A286 SS (NACE) Bolts and 304 SS (NACE) Nuts for Process Heads	CR	•	
316 SS Bolts and 316 SS Nuts for Process Heads	SS	•	b
B7M Bolts and Nuts for Process Heads	B7	•	
316 SS Adapter Flange - 1/2" NPT with CS Bolts	S2	c	
316 SS Adapter Flange - 1/2" NPT with 316 SS Bolts	S3	c	
316 SS Adapter Flange - 1/2" NPT with NACE A286 SS Bolts	S4	c	
316 SS Adapter Flange - 1/2" NPT with B7M Bolts	S5	c	
Hastelloy C Adapter Flange - 1/2" NPT with CS Bolts	T2	c	b
Hastelloy C Adapter Flange - 1/2" NPT with 316 SS Bolts	T3	c	
Monel Adapter Flange - 1/2" NPT with CS Bolts	V2	c	
Monel Adapter Flange - 1/2" NPT with 316 SS Bolts	V3	c	
316 SS Blind Adapter Flange with CS Bolts	B3	•	
316 SS Blind Adapter Flange with 316 SS Bolts	B4	•	
316 SS Blind Adapter Flange with NACE A286 SS Bolts	B5	•	b
316 SS Blind Adapter Flange with B7M Bolts	B6	•	
316 SS Center Vent Drain and Bushing	CV	•	
Side Vent/Drain (End Vent Drain is standard)	SV	•	
Viton Process Head Gaskets	VT	•	
Viton Adapter Flange Gaskets	VF	•	
316 SS Reference Head (Carbon Steel Standard)	HR	•	
Graphite Process Head Gasket	GF	•	
<b>Transmitter Mounting Bracket Options</b>			
Mounting Bracket - Carbon Steel	MB	•	b
Mounting Bracket - 304 SS	SB	•	
Flat Mounting Bracket - Carbon Steel	FB	•	
<b>Diaphragm Options</b>			
Gold plated diaphragm(s) on 316 SS	G1	•	b
Gold plated diaphragm(s) on Monel or Hastelloy ONLY	G2	•	

Table IV continued next page

**TABLE IV - OPTIONS (Continued)**

	Selection	Availability
<b>Services/Calibration/Conformance Options</b>		
User's Manual Paper Copy	UM	•
Clean Transmitter for Oxygen or Chlorine Service with Certificate	0X	h
Over-Pressure Leak Test with F3392 Certificate	TP	•
Calibration Test Report and Certificate of Conformance (F3399)	F1	•
Certificate of Conformance (F3391)	F3	•
<b>Certificate Options</b>		
Certificate of Origin (F0195)	F5	•
NACE Certificate (F0198)	F7	i
<b>Warranty Options</b>		
Additional Warranty - 1 year	W1	•
Additional Warranty - 2 years	W2	•

Approval Body	Approval Type	Location or Classification		
No hazardous location approvals			9X	•
CSA cus	Nonincendive	Nonincendive, CL I, Div 2, Groups A,B,C & D, CL II & III, Div 2, Groups F & G, T4 Ta = 85°C	2N	•
	Non-Sparking	Class I, Ex/AEx nC IIC; T4, Ta ≤ 85°C, Zone 2; IP 66/67		
ATEX	Non-Sparking	Ex II 3 GD; Ex nL IIC; T4, Ta ≤ 85°C, Zone 2; IP 66/67	3N	•

**WARNING** – Division 2 / Zone 2 apparatus may only be connected to processes classified as non-hazardous or Division 2 / Zone 2. Connection to hazardous (flammable or ignition capable) Division 1 / Zone 0, or 1 process is not permitted.

**TABLE V**

Factory Identification	XXXX	•
------------------------	------	---

**RESTRICTIONS**

Restriction Letters	Available Only With		Not Available With	
	Table	Selection	Table	Selection
b	Select only one option from this group			
c	I	-- G		
d	III	_ 00 _ _		
	III	_ _ _ 00		
e			III	_ 00 _ _
h	I	_ 2 _		
i	IV	CR, S4, B5		
k	IV	Select from Table IV S2, S3, S4, S5, T2, T3, V2, V3		

**Notes:** See ST-89 for Published Specials with pricing.  
See ST-95 and User's Manual for part numbers.  
To request a quotation for a non-published "special", fax RFQ to 602-313-6155 or email to ace@honeywell.com

OneWireless and XYR are trademarks and Experion is a registered trademark of Honeywell International Inc.

**Honeywell**

---

**Honeywell Field Solutions**  
Honeywell International Inc.  
2500 W. Union Hills Dr.  
Phoenix, Arizona 85027

©Honeywell International Inc.